



SPRINT ELECTRIC

**Part 3 High Power Modules
PL / PLX 275 - 980**

HG103278
May 2013

V5.15i

**Part 1
PL / PLX
Digital DC Drive**

**Part 2
Application Blocks**

**Part 3
High Power Modules
PL / PLX 275 - 980**



This manual should be read in conjunction with the PL / PLX Digital DC Drive Manual. (Part 1)
Important. See section 2 in main PL / PLX Digital DC Drive Manual for WARNINGS

1 Table of contents

1	Table of contents	1
2	Introduction	2
3	Rating Table	2
4	Mechanical Dimensions PL/X 275 - 440	3
5	Mechanical Dimensions PL/X 520 - 980	4
6	Venting	5
6.1	General venting information	5
6.1.1	When venting kit impractical. Models PL/X 275/315/360/520/600	5
6.1.2	When venting kit impractical. Models PL/X 400/440/700/800/900/980	5
6.2	Venting kit for PL/X 275 - 440	5
6.2.1	PL/X 275 - 440 venting kit diagram	6
6.3	Venting kit for PL/X 520 - 980	6
6.4	Air supply to enclosure	7
6.5	Exhaust air	7
6.6	Venting summary	7
6.6.1	Diagram of air flow	8
7	Product rating table	9
7.1	Product rating labels	9
7.2	Semiconductor fuses	9
7.2.1	PL Models AC fuses for Standard supply voltage (Up to 480V AC)	10
7.2.2	PLX Models AC fuses for Standard supply voltage (Up to 480V AC)	10
7.2.3	PLX Models DC fuses for Standard supply voltage (Up to 480V AC)	11
7.3	Terminal information	11
7.3.1	Control Terminals	11
7.3.2	Powerboard Terminals	11
7.3.3	Terminal tightening torques	12
7.3.4	Forces applied to the power terminals	12
7.3.5	Avoid dropping small objects into unit	12
7.4	Line reactors	13
7.5	Lifting the unit	13
7.5.1	Unit weight	13

2 Introduction

These additional models have all the functionality as described in the **PL / PLX Digital DC Drive Product Manual**. They also have the option of being supplied as HV units that are able to accept AC supply voltages up to 690 Volts for motors with armatures of 750 Volts DC.

All models are available with the high current 3 phase supply terminals in standard top entry, or bottom entry as an option.

3 Rating Table

Nominal maximum continuous shaft ratings

Model		kW at 460 Volt	HP at 460 Volt	HP at 500V	HP at 750V (690V AC) HV models	100% Armature Current DC Amps	100% Field Amps	Dimensions mm W x H x D
PL 2 quadrant PLX 4 quadrant Suffix HV for 690 VAC Suffix BE for bottom entry 3 phase power								
PL and PLX	275	275	370	400	600	650	32 or 50	253 x 700 x 350
PL and PLX	315	315	425	460	690	750	32 or 50	253 x 700 x 350
PL and PLX	360	360	485	520	780	850	32 or 50	253 x 700 x 350
PL* and PLX	400	400	540	580	875	950	32 or 50	253 x 700 x 350
PL* ^{<} and PLX ^{<}	440	440	590	640	970	1050	32 or 50	253 x 700 x 350
PL and PLX	520	520	700	760	1140	1250	64	506 x 700 x 350
PL and PLX	600	600	810	880	1320	1450	64	506 x 700 x 350
PL* and PLX	700	700	940	1020	1530	1650	64	506 x 700 x 350
PL* and PLX	800	800	1080	1170	1760	1850	64	506 x 700 x 350
PL* and PLX	900	800	1200	1300	1950	2050	64	506 x 700 x 350
PL* ^{<} and PLX ^{<}	980	980	1320	1430	2145	2250	64	506 x 700 x 350

* Starred models: (PL*) 2 Quadrant models have electronic regenerative stopping.

PL/X[<] Models have no overload capability.

Standard Models

Main 3 phase supply 50 - 60Hz
Auxiliary 3 phase supply 50 - 60Hz
Control 1 phase (50VA) 50 - 60Hz

Any supply from 12 to 480V AC +/- 10%
Any supply from 100 to 480V AC +/- 10%
Any supply from 110 to 240V AC +/- 10%

High Voltage (HV) Models

Main 3 phase supply 50 - 60Hz
Auxiliary 3 phase supply 50 - 60Hz
Control 1 phase (50VA) 50 - 60Hz

Any supply from 12 to 690V AC +/- 10%
Any supply from 100 to 690V AC +/- 10%
Any supply from 110 to 240V AC +/- 10%

Internal Fan supply

PL/X 275/315/360/400/440 models also need a separate 100VA 240V 50/60Hz ac supply for the fan.

PL/X 520/600/700/800/900/980 models also need a separate 200VA 240V 50/60Hz ac supply for the fan.

OUTPUT VOLTAGE RANGE

Armature PLX and PL* 0 to 1.2 times AC supply. PL 0 to 1.3 times AC supply. (Absolute upper limits)
Note. 1.1 times AC supply is recommended if supply variations exceed -6%.

Field 0 to 0.9 times AC supply on auxiliary terminals. (EL1, EL2, EL3)

OUTPUT CURRENT RANGE

Armature 0 to 100% continuous. 150% for 25 seconds +/- for PLX

Field programmable minimum to 100% continuous with fail alarm.

<Note. Models PL440, PLX440, PL980, PLX980 have no overload capability.

4 Mechanical Dimensions PL/X 275 - 440

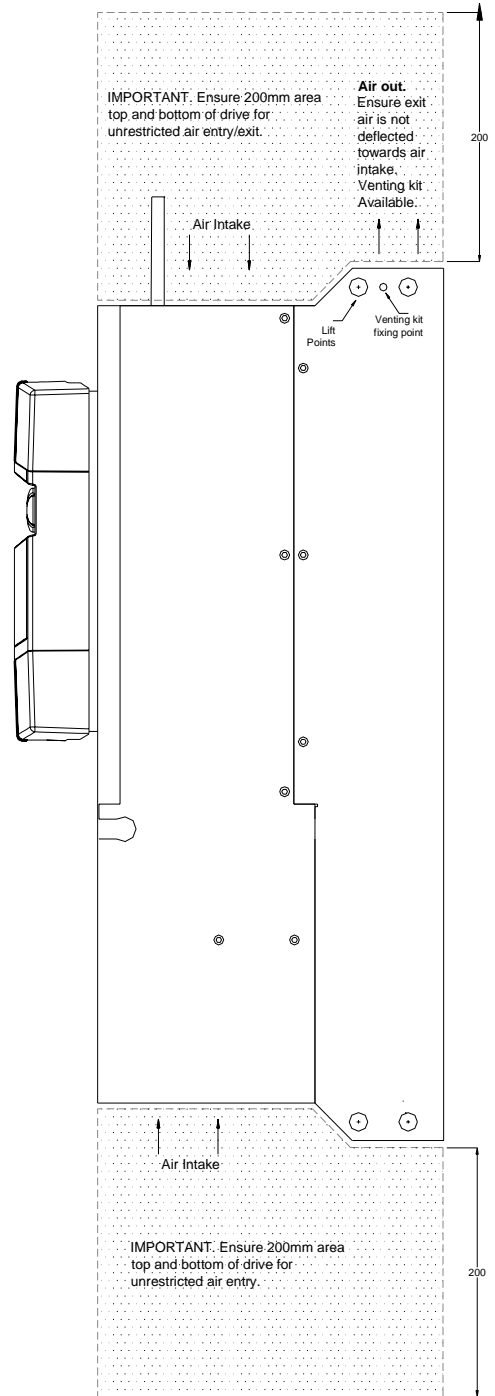
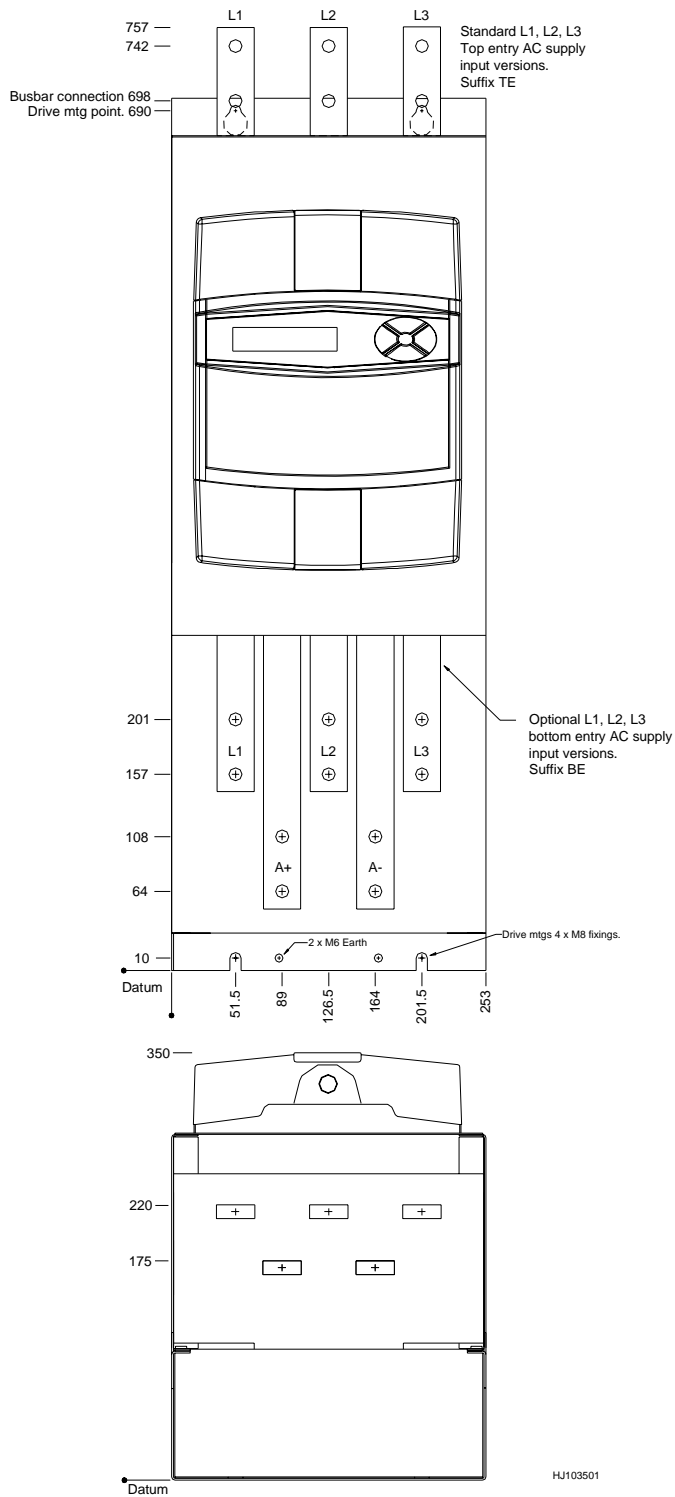

Weight 45KG

See 7.5 Lifting

HJ103501

6 Venting

6.1 General venting information

In order to keep these units within the required operating temperatures under all operating limits they are equipped with a very efficient cooling system. It consists of a powerful centrifugal fan system integral to the unit mounted at the bottom, which blows air over a high dissipation heatsink. Cool air is drawn in both at the top and bottom of the unit and after travelling over the internal heatsink fins, is exhausted at the top of the unit. From here the warm air must be vented from the enclosure used to house the drive.

See 4 Mechanical Dimensions PL/X 275 - 440 and 5 Mechanical Dimensions PL/X 520 - 980 for diagram of air exhaust flow. The unit will run cooler and hence be less stressed if the warm exhaust air is prevented from mixing with the intake air. This can be achieved by the use of the optional venting kit. See below.

6.1.1 When venting kit impractical. Models PL/X 275/315/360/520/600

For these models it is usually sufficient to ensure that the enclosure is fitted with exhaust fans that can evacuate air from the enclosure at a rate at least as high as the drive fan, but within the capacity of the enclosure inlet filter. See 3 Rating Table for airflow ratings. When fitting enclosure fans ensure they are placed in the roof of the enclosure directly above the exhaust outlet of the PL/X.

6.1.2 When venting kit impractical. Models PL/X 400/440/700/800/900/980

For these models it is necessary to keep the exhaust air that is emitted from the top end of the fin section separated from the rest of the enclosure by constructing a duct that can evacuate the exhaust air from the enclosure. If this requires an indirect route then you may need to use external fans to maintain the required airflow. See 3 Rating Table for airflow ratings. Ensure against pollutants entering the port and you may need to use a suitable grill if there is a danger of birds or vermin making it their home.

6.2 Venting kit for PL/X 275 - 440

The venting kit comprises two steel ducts which are designed to telescope together. Hence the duct length from the top of the drive is adjustable between 270mm to 538mm. It consists of three main components.

1) A lower duct which fits within the side cheeks directly above the heatsink exhaust area.

This is secured with 2 M5 screws. See 4 Mechanical Dimensions PL/X 275 - 440 for fixing point drawing. The lower duct is 270mm long from the top edge of the PL/X.

2) The upper duct, which fits over the lower duct section, to extend the total length of the assembly. It has a series of M5 side holes to allow adjustment. Once the desired height is established the upper duct can be screwed to the lower duct through the selected hole, one screw per side. The useful length of the extended duct may be adjusted in steps of approx. 20mm from 270mm to 535mm. The duct must be inserted through a tight fitting rectangular hole in the roof of the enclosure (hole size 100mm x 252mm) and protrude above it by 10-20mm. Then the gap between the duct and the enclosure roof must be sealed (e.g. using tape or flexible filler) to ensure that the exhaust air and pollutants cannot enter into the enclosure.

3) A cowl which is fixed on top of the enclosure to prevent pollutants from dropping into the outlet. The cowl is supplied with 4 off 70mm mounting pillars, and 4 M6 holes must be drilled in the roof of the enclosure, to allow the mounting pillars to be fixed such that the cowl is positioned centrally over the duct. The cowl will overhang the duct by 70mm all the way round. If there is a danger of birds or vermin entering the exhaust port then it is recommend that a suitable grille is added round the edge of the cowl.

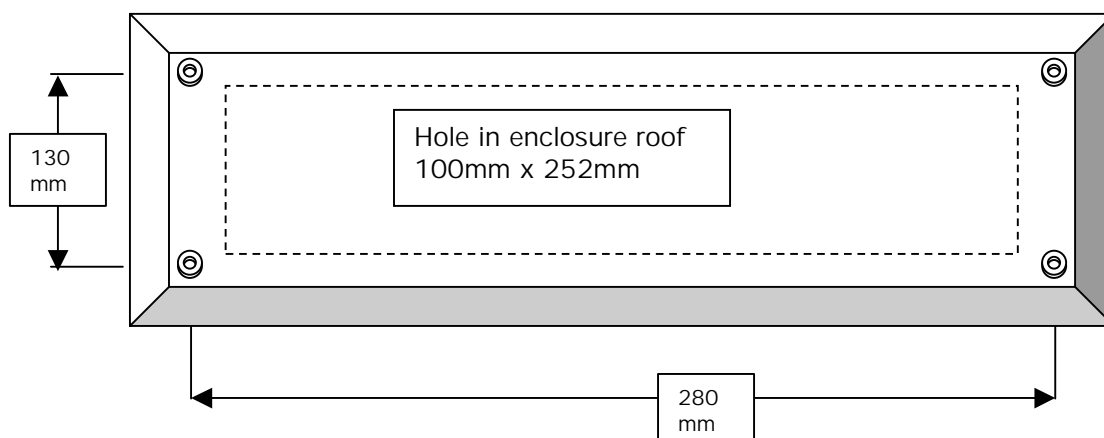

6.2.1 PL/X 275 - 440 venting kit diagram

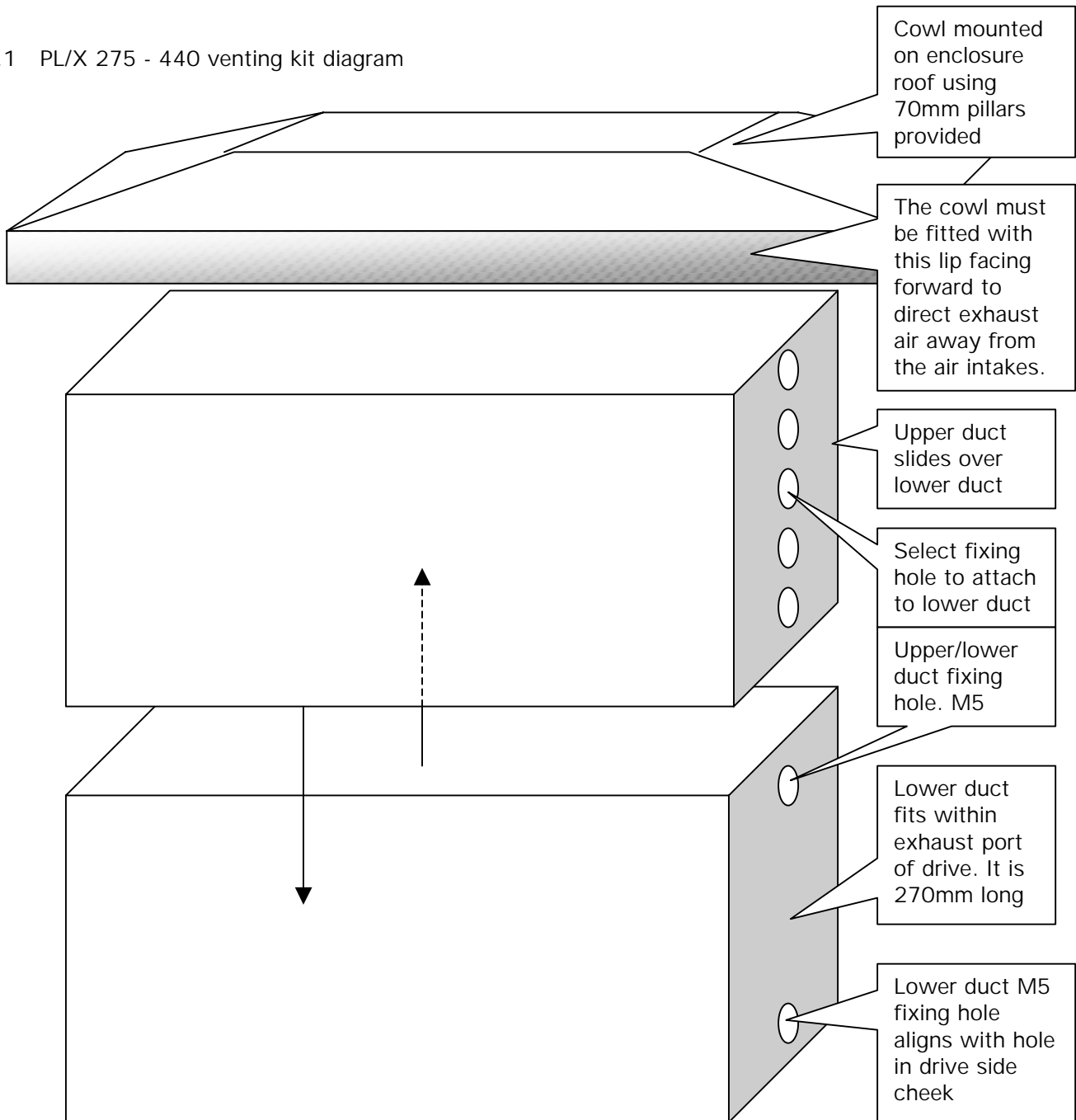

6.3 Venting kit for PL/X 520 - 980

The venting kit comprises a cowl and 2 pairs of steel ducts, each pair being designed to telescope together. Hence the duct length from the top of the drive is adjustable between 270mm to 535mm. There is also an enclosure roof cowl. Each pair is the same unit as described in 6.2 Venting kit for PL/X 275 - 440. There are 2 exhaust ports at the top of the PL/X and each pair of ducts is used with one of the ports. Please read section 5.2 for details about each pair.

The ducts must be inserted through a tight fitting rectangular hole in the roof of the enclosure (hole size 100mm x 504mm) and protrude above it by 10-20mm. Then the gap between the duct and the roof must be sealed (e.g. using tape or flexible filler) to ensure that the exhaust air and pollutants cannot enter into the enclosure. Also the interface between each pair of ducts must be sealed at the top where it protrudes from the roof.

The cowl is fixed on top of the enclosure to prevent pollutants from dropping into the exhaust outlet of the drive. The cowl is supplied with 6 off 50mm mounting pillars, and 6 M6 holes must be drilled in the roof of the enclosure, to allow the mounting pillars to be fixed such that the cowl is positioned centrally over the duct. The cowl will overhang the duct by 70mm all the way round. If there is a danger of birds or vermin entering the exhaust port then it is recommended that a suitable grille is added round the edge of the cowl

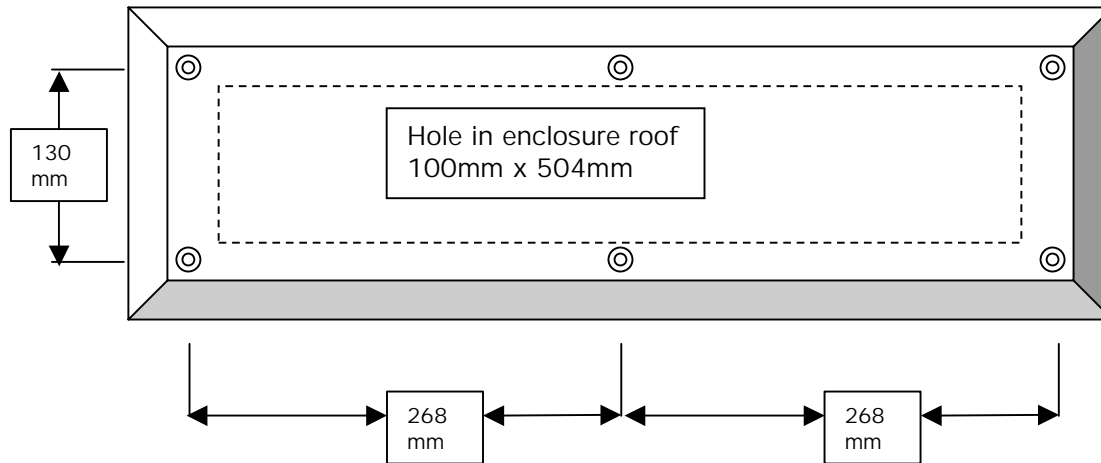

6.4 Air supply to enclosure

It is essential that the enclosure which houses the PL/X is supplied with sufficient cool clean air to satisfy the throughput requirements of the PL/X and any other devices within the enclosure. Do not forget that the current carrying components associated with the drive will be dissipating a considerable amount of heat especially when the system is running at full capacity.

The enclosure must be fitted with air filters suitable for the airborne pollutants encountered within its environment. Together they must have a rated throughput of sufficient capacity for all of the exhaust fans used in the enclosure. If the PL/X is fitted with a venting kit and there is another exhaust fan also operating for cooling other components it is essential that the auxiliary fan does not starve the PL/X of its air supply. This should be avoided if the input filters have sufficient capacity. It is recommended that the PL/X is provided with its own filters, and an enclosure partition used to isolate it from the influence of the rest of the enclosure cooling arrangements.

There should be 2 filters for the PL/X. One to provide air to the lower input port, and one for the upper port. The inlet filters should be fitted to the enclosure adjacent to the input ports at the lower and upper ends of the unit to ensure that the air drawn in is close to where it is needed. The reason for using filters at the top and bottom of the unit is because if only one filter is provided, then when the enclosure door is shut, the airpath from top to bottom may become throttled if the door is close to the face of the unit.

6.5 Exhaust air

After leaving the enclosure containing the PL/X the heated exhaust air will need to be prevented from elevating the ambient temperature of the room that is housing the enclosure by using sufficient ventilation. Alternatively the supply of cooling air may be obtained from outside and ducted to the enclosure.

6.6 Venting summary

Ensure a clean un-interruptible supply of cool filtered air is available for the PL/X and that the exhaust air is adequately and safely disposed of. Use the venting kit to keep the hot exhaust air separate from the cooling input air within the enclosure. Ensure the cooling air is available at the top and bottom of the unit. The PL/X will survive running at high ambient temperatures but possibly at the expense of its potential lifespan. Observe good engineering practice and keep all the components within the enclosure as cool as possible, consistent with avoiding condensation. For installations subjected to high ambient temperatures consider the use of air conditioning to achieve these requirements.

6.6.1 Diagram of air flow

This diagram shows a side view of a unit in an enclosure. This is the recommended method for arranging the flow of cooling air. The fan in the PL/X will draw air into the top and bottom air intakes of the unit.

There are 2 air inlet filters mounted on the door. One adjacent to the lower air intake of the unit and the other adjacent to the upper air intake of the unit.

The exhaust air is exiting the enclosure via the venting kit assembly which is shown with the cowl fitted on the roof of the enclosure.

If this hot exhaust air is likely to raise the temperature of the air being drawn in, then further measures must be taken to direct it away from the system.

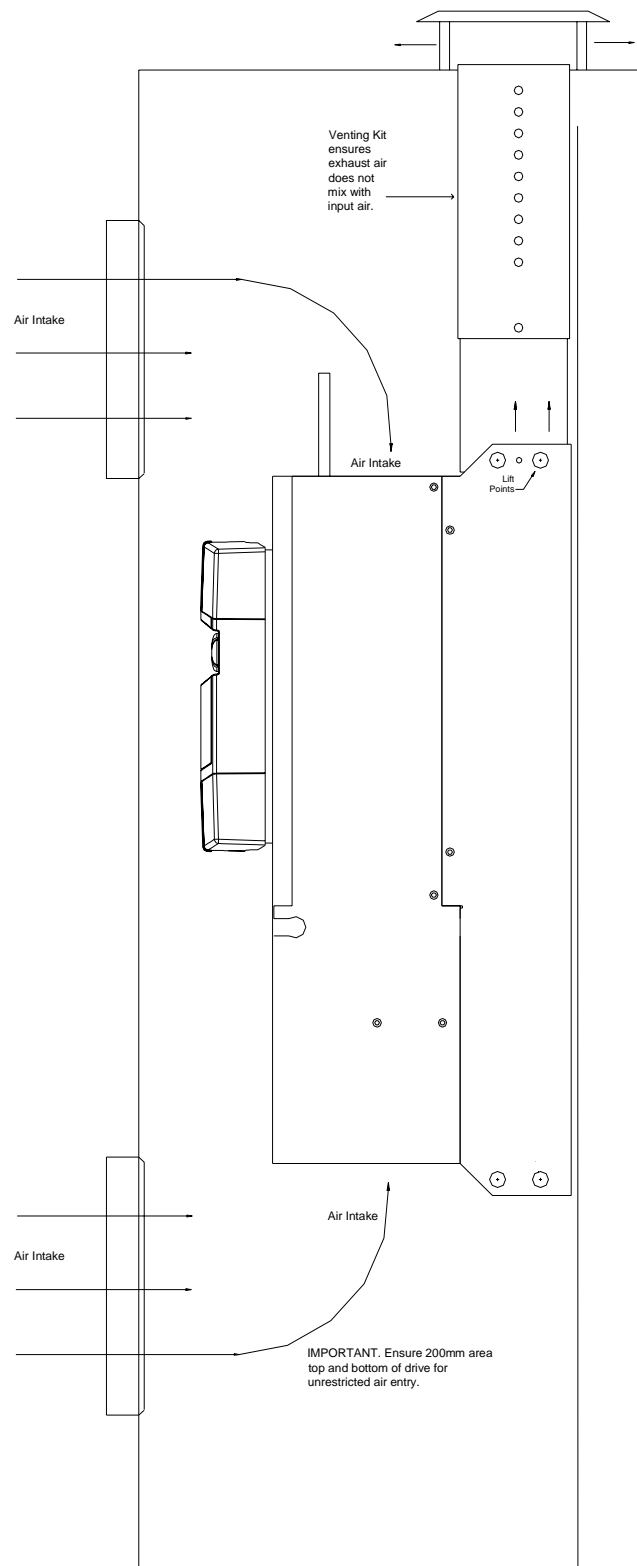

7 Product rating table

Model PL 2Q PLX 4Q	Output power				Max continuous Current (AMPS)			Max field DC output Amps		Line reactor type	Cooling air flow and dissipation	
	At OP = 460V 380 -415AC Kw HP		At 500V 480AC HP		At 750V 690AC HP			std	option		cfm	watts
	AC	IP	DC	OP	AC	IP	DC					
PL/X275	275	370	400	600	530	650	32	50	LR650	400	1700	
PL/X315	315	425	460	690	615	750	32	50	LR750	400	2000	
PL/X360	360	485	520	780	700	850	32	50	LR850	400	2300	
PL/X400	400	540	580	875	780	950	32	50	LR950	400	2500	
PL/X440	440	590	640	970	860	1050	32	50	LR1050	400	2800	
PL/X520	520	700	760	1140	1025	1250	64		LR1250	800	3200	
PL/X600	600	810	880	1320	1190	1450	64		LR1450	800	3700	
PL/X700	700	940	1020	1530	1350	1650	64		LR1650	800	4200	
PL/X800	800	1080	1170	1760	1520	1850	64		LR1850	800	4700	
PL/X900	900	1200	1300	1950	1680	2050	64		LR2050	800	5200	
PL/X980	980	1320	1430	2145	1845	2250	64		LR2250	800	5700	

Important Notes

- 1) Only use UL fuses for installations complying with UL codes.
- 2) 2Q models PL400/440/700/800/900/980 have a regenerative stopping capability.
- 3) The EL1/2/3 connections require 3 auxiliary fuses, (max ratings 80A, I²t 5000).
Sprint part no. Fuse CH00880A. Fuseholder CP102071
When selecting alternative types the fuse current rating must typically be 1.25 X the field current rating of the motor. Max ratings 80A, I²t 5000.
- 4) Please consider the total component dissipation within the enclosure when calculating the required air throughput. This includes the fuses, line reactors and other sources of dissipation.
- 5) 400 Cubic feet per minute is approximately equivalent to 12 cubic metres per minute.
- 6) The output power rating shown is at the 100% rating of the drive and is the power available at the shaft for a typical motor. The actual power available will depend on the efficiency of the motor.
- 7) The high power field output option is an extra cost option and needs to be specified at the time of order.
- 8) The 690V AC supply is an extra cost option and needs to be specified at the time of order. Suffix HV
- 9) The bottom entry AC supply option needs to be specified at the time of order. Suffix BE
- 10) Models PL/X 900/980 have maximum ambient temperature rating of 35C. Derate by 100 Amps for 40C.
- 11) Derate by 1% per Deg C for ambient temperatures above 40C up to 50C.

7.1 Product rating labels

The product rating labels are located on the unit under the upper end cap. The product serial number is unique and can be used by the manufacturer to identify all ratings of the unit. The power ratings and model type are also found here, along with any product standard labels applicable to the unit.

7.2 Semiconductor fuses

WARNING. All units must be protected by correctly rated semi-conductor fuses. Failure to do so will invalidate warranty. For semi-conductor fuses please refer to supplier.

Model PL 2Q PLX 4Q	Main fuses Max I ² t	Main fuses Max I ² t	Main fuses Max I ² t	Main fuses Max I ² t
	480V AC 50Hz AC	480V AC 60Hz AC	690V AC 50Hz AC	690V AC 60Hz AC
	Standard	Standard	High Voltage	High Voltage
PL/X275	1,170,000	1,170,000	810,000	770,000
PL/X315	1,170,000	1,170,000	810,000	770,000
PL/X360	1,170,000	1,170,000	810,000	770,000
PL/X400	1,304,000	1,290,000	1,260,000	1,200,000
PL/X440	1,304,000	1,290,000	1,260,000	1,200,000
PL/X520	3,240,900	3,240,900	2,243,700	2,132,900
PL/X600	3,240,900	3,240,900	2,243,700	2,132,900
PL/X700	4,212,000	4,212,000	2,916,000	2,772,000
PL/X800	4,694,400	4,694,400	2,916,000	2,772,000
PL/X900	4,694,400	4,694,400	2,916,000	2,772,000
PL/X980	4,694,400	4,694,400	2,916,000	2,772,000

7.2.1 PL Models AC fuses for Standard supply voltage (Up to 480V AC)

PL AC Fuses	SPRINT PART No.	SIZE	CURRENT RATING (A)	MOUNTING	DEPTH mm	FERRAZ PART NUMBER AND REFERENCE	
PL275KW (650A)	CH103301	31	800	TTF	50.6	6,9 URD 31 TTF 0800	Y300401
PL275KW (650A)	CH103301	32	800	TTF	50.6	6,9 URD 32 TTF 0800	P300071
PL275KW (650A)	CH103301	33	800	TTF	50.6	6,9 URD 33 TTF 0800	Z300080
PL315KW (750A)	CH103302	32	900	TTF	50.6	6,9 URD 32 TTF 0900	Q300072
PL315KW (750A)	CH103302	33	900	TTF	50.6	6,9 URD 33 TTF 0900	A300081
PL360KW (850A)	CH103303	32	1000	TTF	50.6	6,9 URD 32 TTF 1000	S300074
PL360KW (850A)	CH103303	33	1000	TTF	50.6	6,9 URD 33 TTF 1000	B300082
PL400KW (950A)	CH103304	32	1100	TTF	50.6	6 URD 32 TTF 1100	M300759
PL400KW (950A)	CH103304	33	1100	TTF	50.6	6,9 URD 33 TTF 1100	C300083
PL440KW (1050A)	CH103305	33	1250	TTF	50.6	6,9 URD 33 TTF 1250	D300084
PL440KW (1050A)	CH103305	2x33	1250	TTF	67.6	6,9 URD 233 TTF 1250	D300268
PL520KW (1250A)	CH103306	33	1500	TTF	50.6	6 URD 33 TTF 1500	Y300585
PL520KW (1250A)	CH103306	33	1600	TTF	50.6	6 URD 33 TTF 1600	Z300586
PL600KW (1450A)	CH103307	33	1800	TTF	50.6	6 URD 33 TTF 1800	A300587
PL600KW (1450A)	CH103307	2x33	1800	PLAF	55.5	6,9 URD 233 PLAF 1800	B300427
PL700KW (1650A)	CH103308	33	2000	TTF	50.6	5,5 URD 33 TTF 2000	B300588
PL700KW (1650A)	CH103308	2x33	2000	PLAF	91.5	6 URD 233 PLAF 2000	R302235
PL800KW (1850A)	CH103309	2x33	2200	PLAF	91.5	6 URD 233 PLAF 2200	Q302234
PL800KW (1850A)	CH103309	44	2200	TQF	65	7,5 URD 44 TTQF 2200	K235184
PL900KW (2050A)	CH103310	44	2500	TQF	65	7 URD 44 TTQF 2500 BS	C221538
PL900KW (2050A)	CH103310	44	2400	TQF	65	7,5 URD 44 TTQF 2400	W233906
PL980KW (2250A)	CH103467	44	2500	TQF	65	7 URD 44 TTQF 2500 BS	C221538

7.2.2 PLX Models AC fuses for Standard supply voltage (Up to 480V AC)

PLX AC	SPRINT PART No.	SIZE	CURRENT RATING (A)	MOUNTING	DEPTH (mm)	FERRAZ PART NUMBER AND REFERENCE	
PLX275KW (650A)	CH103311	32	800	TTF	50.6	6,9 URD 32 TTF 0800	P300071
PLX275KW (650A)	CH103311	33	800	TTF	50.6	6,9 URD 33 TTF 0800	Z300080
PLX315KW (750A)	CH103312	32	900	TTF	50.6	6,9 URD 32 TTF 0900	Q300072
PLX315KW (750A)	CH103312	33	900	TTF	50.6	6,9 URD 33 TTF 0900	A300081
PLX360KW (850A)	CH103313	32	1000	TTF	50.6	6,9 URD 32 TTF 1000	S300074
PLX360KW (850A)	CH103313	33	1000	TTF	50.6	6,9 URD 33 TTF 1000	B300082
PLX400KW (950A)	CH103314	33	1100	TTF	50.6	6,9 URD 33 TTF 1100	C300083
PLX400KW (950A)	CH103314	2x33	1250	TTF	67.6	6,9 URD 233 TTF 1250	D300268
PLX440KW (1050A)	CH103315	2x33	1250	TTF	67.6	6,9 URD 233 TTF 1250	D300268
PLX440KW (1050A)	CH103315	2x33	1400	TTF	67.6	6,9 URD 233 TTF 1400	E300269
PLX520KW (1250A)	CH103316	73	1400	TTF	74	8,5 URD 73 TTF 1400**	S300718
PLX520KW (1250A)	CH103316	2x33	1600	TTF	67.6	6,9 URD 233 TTF 1600	F300270
PLX600KW (1450A)	CH103317	2x33	1800	PLAF	55.5	6,9 URD 233 PLAF 1800	B300427
PLX600KW (1450A)	CH103317	2x32	1800	TDF	91.6	6,9 URD 232 TDF 1800	X300216
PLX700KW (1650A)	CH103318	2x33	1800	PLAF	55.5	6,9 URD 233 PLAF 1800	B300427
PLX700KW (1650A)	CH103318	2x32	1800	TDF	91.6	6,9 URD 232 TDF 1800	X300216
PLX800KW (1850A)	CH103319	2x33	2200	PLAF	55.5	6 URD 233 PLAF 2200	Q302234
PLX900KW (2050A)	CH103320	44	2400	TQF	65	7,5 URD 44 TTQF 2400	W233906
PLX980KW (2250A)	CH103468	44	2500	TQF	65	7 URD 44 TTQF 2500 BS	C221538

7.2.3 PLX Models DC fuses for Standard supply voltage (Up to 480V AC)

For PLX units used in applications in which regeneration occurs for most or all of the time, it is recommended to fit a DC side semi-conductor fuse. This will further protect the unit in the event of an unsequenced power loss when regeneration is taking place

Note. It is not normally necessary to use DC fuses with the PL Models but if required then these fuses can be used. Example. A *PL model that allows regenerative stopping is employed on a site that suffers from a higher than normal amount of power brown outs or blackouts.

PL/X DC Fuses	SPRINT PART No.	SIZE	CURRENT RATING (A)	MOUNTING	DEPTH (mm)	FERRAZ PART NUMBER AND REFERENCE	
PL/X275KW (650A)	CH103321	33	900	TTF	50.6	6,9 URD 33 TTF 0900	A300081
PL/X275KW (650A)	CH103321	33	1000	TTF	50.6	6,9 URD 33 TTF 1000	B300082
PL/X315KW (750A)	CH103322	33	1100	TTF	50.6	6,9 URD 33 TTF 1100	C300083
PL/X315KW (750A)	CH103322	33	1250	TTF	50.6	6,9 URD 33 TTF 1250	D300084
PL/X360KW (850A)	CH103313	33	1250	TTF	50.6	6,9 URD 33 TTF 1250	D300084
PL/X360KW (850A)	CH103313	33	1400	TTF	50.6	6,9 URD 33 TTF 1400	E300085
PL/X400KW (950A)	CH103324	33	1400	TTF	50.6	6,9 URD 33 TTF 1400	E300085
PL/X400KW (950A)	CH103324	73	1250	TTF	74	9 URD 73 TTF 1250	T300696
PL/X440KW (1050A)	CH103325	33	1400	TTF	50.6	6,9 URD 33 TTF 1400	E300085
PL/X440KW (1050A)	CH103325	73	1400	TTF	74	8,5 URD 73 TT F 1400	S300718
PL/X520KW (1250A)	CH103326	2x73	1800	TTF	91	11 URD 273 TTF 1800	S302236
PL/X520KW (1250A)	CH103326	2x33	1800	PLAF	55.5	6,9 URD 233 PLAF 1800	B300427
PL/X600KW (1450A)	CH103327	2x32	2000	TDF	91.5	6,9 URD 232 TDF 2000	Y300217
PL/X600KW (1450A)	CH103327	2x73	2000	TTF	91	10 URD 273 TTF 2000	P300738
PL/X700KW (1650A)	CH103328	2x73	2200	TTF	91	9,5 URD 273 TTF 2200	Q300739
PL/X700KW (1650A)	CH103328	2x73	2200	PLAF	78	9,5 URD 273 PLAF 2200	M301909
PL/X800KW (1850A)	CH103329	44	2700	TTQF (TQF)	65	6,9 URD 44 TTQF 2700	E239158
PL/X800KW (1850A)	CH103329	2x73	2500	PLAF	78	9 URD 273 PLAF 2500	R300740
PL/X900KW (2050A)	CH103330	44	3000	TTQF (TQF)	65	6,9 URD 44 TTQF 3000	
PL/X900KW (2050A)	CH103330	2x73	2800	PLAF	78	8,5 URD 273 PLAF 2800	S300741
PL/X980KW (2250A)	CH103469	44	3200	TTQF (TQF)	65	6,9 URD 44 TTQF 3200	S221805

7.3 Terminal information

7.3.1 Control Terminals

See Part 1 main product manual for control terminal information section 3.3.3, 3.4 and 3.5.

7.3.2 Powerboard Terminals

Remove busbar cover plate to reveal powerboard terminals.

For terminals T41 to T53 refer to main manual Part 1 section 3.3.3, for power terminals section 3.3.2.

7.3.2.1 Fan supply input

Remove busbar cover plate to reveal powerboard terminals. The fan supply input terminals are located on the lower left hand edge of the powerboard marked AC FAN SUPPLY B1 N, B2 L.

Internal Fan supply

PL/X 275/315/360/400/440 models need a separate 100VA 240V 50/60Hz ac supply for the fan.

PL/X 520/600/700/800/900/980 models need a separate 200VA 240V 50/60Hz ac supply for the fan.

Note. If the fan supply fails, or is not present on power up then a warning message HEATSINK OVERTEMP is displayed on the front of the unit, and operation of the motor will be prevented. See also the main manual section 8.1.11.13 for further details of this message related to actual overtemp events.

7.3.2.2 Field supply input and output

Remove busbar cover plate to reveal powerboard terminals

The terminals EL1 EL2 EL3 F+ F- are M6 stud types found on the bottom right hand corner of the powerboard. Further information on utilising these terminals is in Section 4 Basic Application and Section 14.9 Wiring instructions, in the main manual. Also section 3.3.2 for specification. See section 7 Product rating table, in this Part 3.

7.3.3 Terminal tightening torques

Terminals	Model	Tightening torque
Terminals 1 to 100	PL/X 275-980	4 lb-in or 0.5 N-m
EL1 EL2 EL3 F+ F-	PL/X 275-980	35 lb-in or 3.9 N-m
L1 L2 L3 A+ A-	PL/X 275-980	242 lb-in or 27 N-m
Fan supply terminals	PL/X 275-980	9 lb-in or 1.0 N-m

7.3.4 Forces applied to the power terminals

Avoid applying mechanical stress to the heavy current terminals L1/2/3 A+ A-. Please ensure that any cables or busbars that are bolted to these terminals are supported within the enclosure. Do not rely on the drive terminals to support the weight of the external connections.

Do not use the connecting bolt to hold the terminal and the connecting cable or busbar in alignment, otherwise, if they have been levered into alignment prior to inserting the bolt, there will be a permanent stress on the terminal. Always support the connection to the terminal such that the only purpose of the terminal bolt is to tighten them together and not to maintain their relative position to each other. The respective holes in the terminal and the connecting busbar should remain in alignment without the aid of the terminal bolt. Then you can be sure that there is minimum stress on the drive terminal busbar.

When tightening the connecting bolts of the terminals L1/2/3 A+ A- please ensure that the busbar is not subjected to a turning moment as the nut is torqued down. To do this always use two spanners, one on the bolt head to provide a counter torque and one on the nut to provide tightening torque.

7.3.5 Avoid dropping small objects into unit

If the unit is in the horizontal plane then there is a danger that objects may be accidentally dropped into the air intake grille when connecting the busbars to the terminals. Or when the unit is vertical, dropping washers into the fin section at the top, or objects dropping through the upper air intake grill. As a precaution it is advised that a temporary cover be utilised over these areas when working on the unit, e.g. a piece of cardboard. Do not forget to remove the temporary cover prior to starting the unit. If anything is dropped into the unit then it may interfere with the fan rotation.

7.4 Line reactors

Only use UL certified line reactors for installations complying with UL codes. These line reactors are not certified. Refer to supplier for certified alternatives.

Model PL 2Q PLX 4Q	Max continuous Current (AMPS)		Line reactor Type 480V AC Supply	Line reactor Type 690V AC Supply
	Input AC	Output DC		
PL/X275	530	650	LR650	LR650HV
PL/X315	615	750	LR750	LR750HV
PL/X360	700	850	LR850	LR850HV
PL/X400	780	950	LR950	LR950HV
PL/X440	860	1050	LR1050	LR1050HV
PL/X520	1025	1250	LR1250	LR1250HV
PL/X600	1190	1450	LR1450	LR1450HV
PL/X700	1350	1650	LR1650	LR1650HV
PL/X800	1520	1850	LR1850	LR1850HV
PL/X900	1680	2050	LR2050	LR2050HV
PL/X980	1845	2250	LR2250	LR2250HV

To obtain line reactor dimensions please refer to supplier

7.5 Lifting the unit

Use the lifting points provided. There are lifting holes at each end of the unit. Attach a loop of suitable rope (approx. 1.2m for PL/X275-440 and 1.5m for PL/X520-980) between the lifting holes at each side at the top end, and a similar loop at the bottom end, to assist in lifting the unit out of its container. When lifting the unit keep it in either the horizontal or vertical plane to avoid deforming the side cheeks at the lifting points. Use the top end lifting loop to assist in presenting the unit onto the back panel. The fixing holes at the top of the unit are designed with a keyhole shape to allow the unit to be initially hung on the securing bolts. These should be fixed on the back panel prior to presenting the unit into the enclosure.

Alternatively a small fork lift may be employed if the wheel has access under the door of the enclosure. (It is usually possible to have access for one fork from the side of a typical enclosure with the side panel removed). If access can be gained this way then you will need to bolt some temporary wooden extensions to the lifting holes at the bottom of the unit in order to stand the unit on the fork which will enter the enclosure).

7.5.1 Unit weight

The PL/X 275-440 weighs 45Kg. The PL/X 520-980 weighs 90Kg.

Sprint Electric Limited
Arundel, UK

Tel. + 44 (0)1903 558080
Fax. + 44 (0)1243 558099
Email. info@sprint-electric.com

www.sprint-electric.com

