

B150

Dynamic Brake



B150 Dynamic Braking Unit

Braking Documentation

B150

Dynamic Brake

B150 Dynamic Braking Unit
Braking Documentation

Edition: March 2012

SD70DF01BI Rev. B

SAFETY SYMBOLS

Always follow safety instructions to prevent accidents and potential hazards from occurring.



This symbol means improper operation may result in serious personal injury or death.



Identifies shock hazards under certain conditions. Particular attention should be given because dangerous voltage may be present. Maintenance operation should be done by qualified personnel.

Edition March2012

This publication could present technical imprecision or misprints. The information here included will be periodically modified and updated, and all those modifications will be incorporated in later editions. To consult the most updated information of this product you might access through www.power-electronics.com where the latest version of this manual can be downloaded.

Revisions

Date	Revision	Description
08 / 10 / 2008	A	First edition

INDEX

SAFETY INSTRUCTIONS	7
1. INTRODUCTION	13
1.1. Description of the B150 Braking Unit	13
2. TECHNICAL CHARACTERISTICS	15
2.1. Electrical Data	15
3. INSTALLATION AND CONNECTION	16
3.1. Installation of B150 Unit	16
3.2. Power and Control Connections for B150 Unit	18
3.3. Operating Mode Setting	27
3.4. Local Settings and Indications	33
3.5. Safety Connection for the 'No Fault' Relay	34
3.6. Mounting of the Dynamic Braking Resistor	34
3.7. Resistor Thermal Protection	35
4. RECOMMENDATIONS FOR APPLICATIONS	36
4.1. Selection of the Dynamic Braking Resistor	37
5. PARAMETER SETTING FOR SD700 SERIES	39
5.1. Group 17 – G17: Brake	39
6. TROUBLESHOOTING AND MAINTENANCE	40
6.1. Troubleshooting	40
6.2. Maintenance	41
7. ANNEX A. OPTIONAL BOARD FOR BRAKING UNIT SLAVE MODE ..	41

SAFETY INSTRUCTIONS

IMPORTANT!

- Safety instructions showed in this manual are useful to teach user how to use the product in a correct and safety way with the purpose of preventing possible personal injuries or property damages.
- Safety messages included here are classified as it follows:



ALARM

Make sure of taking corresponding protection for ESD Electrostatic Discharge in case of manipulation of the PCB.

Otherwise, the unit could result damaged due to this effect.

Implement the connections of the braking unit after checking the equipment is not powered.

Otherwise, there is risk of connection error and the unit may get damaged.

Make sure of connecting correctly the braking unit to the drive.

Otherwise, there is risk of connection error and the unit may get damaged.

Do not remove the cover while the drive is powered or the braking unit is in operation.

Otherwise, electric shock could occur.

Do not run the braking unit with the front cover removed.

Otherwise, you may get an electric shock due to the high voltage terminals or exposure of charged capacitors.

Do not remove the cover except for periodic inspections or wiring, even if the input power is not applied.

Otherwise, you may access the charged circuits and get an electric shock.

Wiring and periodic inspections should be performed at least 10 minutes after disconnecting the input power of the equipment which is going to be connected with this braking unit and after checking the DC Link voltage is discharged with a meter (below 30VDC).

Otherwise, you may get an electric shock.

Operate the switches with dry hands.

Otherwise, you may get an electric shock.

Do not use cables with damaged insulation.

Otherwise, you may get an electric shock.

Do not subject the cables to the abrasions, excessive stress, heavy loads or pinching.

Otherwise, you may get an electric shock.



CAUTION

Install the braking unit on a non-flammable surface. Do not place flammable material nearby.

Otherwise, fire could occur.

Disconnect the input power if the drive or the braking unit gets damaged.

Otherwise, it could result in a secondary accident or fire.

After the input power is applied or removed, the drive will remain hot for a couple of minutes.

Touching hot parts may result in skin burns.

Do not apply power to a damaged drive or braking unit, or to a drive or braking unit with parts missing even if the installation is complete.

Otherwise, fire or accident could occur.

Do not allow lint, paper, wood chips, dust, metallic chips or other foreign matter into the braking unit.

Otherwise, fire or accident could occur.



WARNINGS

RECEPTION

- Material of Power Electronics is carefully tested and perfectly packed before leaving the factory.
 - In the even of transport damage, please ensure that you notify the transport agency and POWER ELECTRONICS: 902 40 20 70 (International +34 96 136 65 57) or your nearest agent, within 24hrs from receipt of the goods.
-

UNPACKING

- Make sure received merchandise corresponds with delivery note, models and serial numbers.
 - Each equipment is supplied with a technical manual.
-

RECYCLING

- Packing of the equipments should be recycled. For this, it is necessary to separate different materials included (plastic, paper, cardboard, wood, ...) and deposit them on proper banks.
 - Waste products of electric and electronic devices should be selectively collected for their correct environmental management.
-

SAFETY

- Before operating the equipment, read this manual thoroughly to gain and understanding of the unit. If any doubt exists then please contact POWER ELECTRONICS, (902 40 20 70 / +34 96 136 65 57) or your nearest agent.
 - Wear safety glasses when operating the braking unit close to the drive with power applied and the front cover is removed.
 - Handle the braking unit with care according to its weight.
 - Do not place heavy objects on the braking unit.
 - Install the braking unit according to the instructions within this manual.
-

- Ensure that the mounting orientation is correct.
 - Do not drop the braking unit or subject it to impact.
 - The B150 braking unit consists of electronic cards sensitive to static electricity. Use procedures to avoid it.
 - The B150 unit operates with **High DC Voltage (VDC) Circuits**. Be careful with the application and the protection of the B150 and the braking resistors.
 - Heat generated by the braking resistors connected to the B150 unit operating at full power or in fault status, can reach a power value above 220kW. The design of the system must include **thermal Fault Safety protection** to prevent the risk of fire under any condition.
 - The B150 braking unit operates with VDC. The voltage value can be 735VDC whenever main voltage is present. Make sure that the B150 braking unit and any drive and load connected to it, are **completely discharged** before removing the gland plate, the cover or before trying to access in order to make any maintenance action.
 - The B150 dynamic braking unit provides with a functional braking. It is not a safety brake and for this reason, it must not be used as it. When the application requires it, it must be used a safety mechanical brake separately.
 - The installer is must follow the manufacturer recommendations and the **local and national safety and electrical regulations. It is responsible of the safety and correct installation of the system.**
 - The access plate of the B150 unit and its cover must be correctly installed to meet the specified protection degree IP20.
-

CONNECTIONS PRECAUTIONS WITH SD700 DRIVE

- The power connection between the SD700 (HVDC+ and HVDC -) and the dynamic brake should be done with unipolar twisted pair with a turn ratio of 200mm. The cable length should be less than 2 m otherwise the cable inductance could damage the Dynamic brake due to overvoltage pulses.
- The power connection between the B150 and the resistors should be done with unipolar twisted pair with a turn ratio of 200mm. The cable length should be less than 10 m otherwise the cable inductance could damage the Dynamic brake due to overvoltage pulses.
- To ensure correct operation of the drive it is recommended to use a SCREENED CABLE for the control wiring.
- For EMERGENCY STOP, make sure supply circuitry is open.
- It is not recommended to use a 3-wire cable for long distances. Due to increased leakage capacitance between conductors, over-current protective feature may not operate correctly.
- Do not use power factor correction capacitors, surge suppressors, or RFI filters on the output side of the drive. Doing so may damage these components.
- Always check whether the DC Link LED is OFF before wiring terminals. The capacitors may hold high-voltage even after the input power is disconnected. Use caution to prevent the possibility of personal injury.
- In case of using fuse protection, select suitable fast action DC fuses.

TRIAL RUN

- Follow the steps described in this manual.
 - Always apply voltage and current signals to each terminal that are within levels indicated within this manual. Otherwise, damage to the braking unit may result.
 - Read the Getting Started Manual of the SD700 drive for additional information.
-

OPERATION PRECAUTIONS WITH SD700 DRIVE

- When the Auto Restart function is enabled, keep clear of driven equipment, as the motor will restart suddenly after a fault is reset.
 - The “STOP / RESET” key on the keypad is active only if the appropriate function setting has been made. For this reason, install a separate EMERGENCY STOP push button that can be operated at the equipment.
 - If a fault reset is made with the reference signal still present then a restart will occur. Verify that it is permissible for this to happen, otherwise an accident may occur.
 - Do not modify or alter anything within the drive.
 - Before programming or operating the SD700 Series, initialise all parameters back to factory default values.
-

EARTH CONNECTION

- The drive is a high frequency switching device and leakage current may flow. Ground the drive to avoid electrical shock. Use caution to prevent the possibility of personal injury.
 - Connect only to the dedicated ground terminal of the drive. Do not use the case or the chassis screw for grounding.
 - When installing, grounding wire should be connected first and removed last.
 - The earth cable must have a minimal cross sectional area that meets local country electrical regulations.
 - Motor ground must be connected to the drive ground terminal and not to the installation's ground.
 - Installation ground must be connected to the drive ground terminal.
 - Eventually the resistor and dynamic brake may suffer a ground fault. Connect the dedicated terminal to the ground to prevent any damaged.
-

1. INTRODUCTION

1.1. Description of the B150 Braking Unit

The use of the dynamic braking provides the drives of SD700 Series with the capacity of covering the regeneration probably generated during deceleration with high-inertia loads (like a large fan or centrifuge, ...) or a regenerative load (like the descent of an elevation crane, ...). The dynamic braking unit turns this regenerative energy into heat through the dynamic braking resistors, so keeping the motor control.

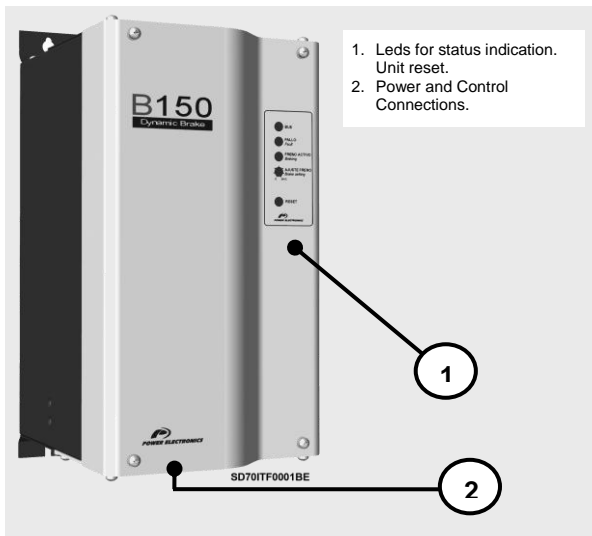

Figure 1.1 Description of the B150 Braking Unit

The B150 is the main power switching element of such a dynamic braking system.

The B150 braking unit can be controlled in Master mode by built-in voltage sensing circuit. At the same time, the equipment provides with an output for multiple B150 slaves in order to provide an extra-braking capacity.

B150 have a safety relay 'no fault', that connected to one SD700 digital input and configured as a fault, allows knowing and controlling the fault status of the brake.

The B150 series is composed by three models that depends on the rated voltage of the drive. Units B150.2 (230VAC) and B150 (400VAC-500VAC) can switch up to 300A at 735VDC into a resistive load with a maximum peak power of 220kW. Unit B150.6 (690VAC) can switch up to 200A at 1155VDC into a resistive load with a maximum peak power of 230kW.

It is necessary to select and purchase dynamic braking resistors adjustable to each application.

2. TECHNICAL CHARACTERISTICS

2.1. Electrical Data

		DYNAMIC BRAKE B150																													
		B150.2	B150	B150.6																											
ELECTRICAL SPECIFICATIONS	Using voltage for brake (jumpers)	230VAC,	400VAC, 500VAC,	690VAC																											
	Maximum switch current	300A (R=2.4Ω @ 735VDC)		200A (R=5.75Ω @ 1155VDC)																											
	Continuous current rating	150A (R=4.9Ω at 735VDC)		100A (R=11.5Ω @ 1155VDC)																											
	Minimum resistor rating	2.4Ω		5.75Ω																											
PROTECTION	IGBT desaturation trip	Trip when switching into to short-circuited resistor																													
	IGBT heat sink over temperature	Trip when IGBT heat sink over 90°C																													
	Over temperature of the resistors	Available digital input for external trip connection (thermal sensor of the external resistor)																													
BRAKING VOLTAGE CONTROL	Mode selection	Master (internal sensing circuit) Slave (by external drive)																													
	Potentiometer for fine setting	<table border="1"> <thead> <tr> <th rowspan="2">Vin (VAC)</th> <th rowspan="2">VBus max. (VDC)</th> <th colspan="3">Activating Voltage for Brake (VDC)</th> </tr> <tr> <th>0%</th> <th>+5%</th> <th>-5%</th> </tr> </thead> <tbody> <tr> <td>230</td> <td>360</td> <td>400</td> <td>420</td> <td>380</td> </tr> <tr> <td>400</td> <td>625</td> <td>730</td> <td>765</td> <td>695</td> </tr> <tr> <td>500</td> <td>780</td> <td>780</td> <td>820</td> <td>740</td> </tr> <tr> <td>690</td> <td>1080</td> <td>1100</td> <td>1155</td> <td>1045</td> </tr> </tbody> </table>			Vin (VAC)	VBus max. (VDC)	Activating Voltage for Brake (VDC)			0%	+5%	-5%	230	360	400	420	380	400	625	730	765	695	500	780	780	820	740	690	1080	1100	1155
Vin (VAC)	VBus max. (VDC)	Activating Voltage for Brake (VDC)																													
		0%	+5%	-5%																											
230	360	400	420	380																											
400	625	730	765	695																											
500	780	780	820	740																											
690	1080	1100	1155	1045																											
OUTPUTS	Safety relay 'No Fault'	Changeover relay NO-NC. Activated at normal conditions, deactivated at fault conditions or no power.																													
AMBIENT CONDITIONS	Protection degree	IP20																													
	Operating temperature	0°C to +50°C																													
	Storage temperature	-25°C to +80°C																													
	Relative humidity	80% at 31°C up to 50% at 50°C																													
	Altitude	1000m																													
	Altitude derating (>1000m)	-1% per 100m, up to 3000m max.																													

Note: The cable input plate and the cover of the equipment must be correctly installed to guarantee the specified protection degree for the equipment.

3. INSTALLATION AND CONNECTION

3.1. Installation of B150 Unit

The B150 has compact dimensions that make easy the installation and connection.



CAUTION

The variable speed drives on where B150 dynamic braking units are connected operate with high voltage.

Make sure the power supply has been disconnected and let at least 10 minutes elapse in order to guarantee the DC bus has been discharged, before installing B150 Braking Unit. Otherwise, you may get an electric shock.

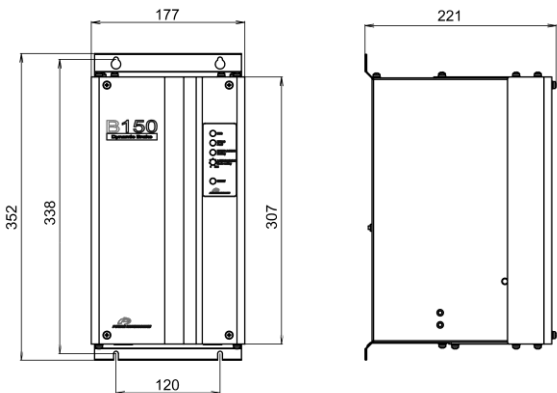

SD70DTF0008AE

Figure 3.1 Dimensions for B150 Braking Unit

It is recommended to install the B150 braking unit in a suitable environment in order to the offered performances go on for more time.

The ambient temperature should not be below 0°C and above 50°C. The relative humidity should be lower than 80% at 31°C (decreasing linearly down to 50% when temperature is 50°C). There must be not condensation. Do not install the equipment in direct sunlight, for better operation.

The mounting and installation must be in vertical orientation saving the minimum distances indicated in figure 3.2 and with the back panel fixed to the wall to ensure proper cooling.

The installation should be done leaving a free-space of 150mm vertically and 50mm horizontally from adjacent equipments in order to avoid the ambient temperature exceeds 50°C. Make sure the air flow from the fan is not obstructed.

Do not install multiple straight B150 units above other cooling units to avoid the accumulation of hot air in the installation area.

Avoid cooling the B150 unit with the heated air coming from the resistors. Otherwise the B150 could suffer overheating problems.

If the B150 unit is installed in a cabinet, make sure the available cooling is enough in order to internal air does not get hot and does not exceed the specified temperature.

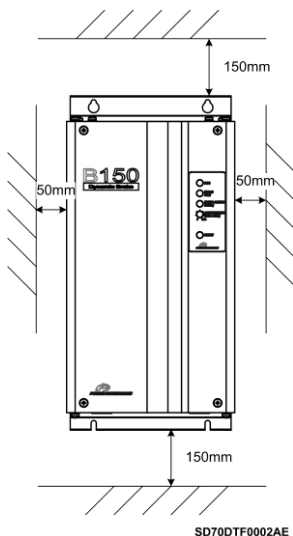

Figure 3.2 Minimum recommended distances for the installation

3.2. Power and Control Connections for B150 Unit

Some applications require a mechanical brake as safety measure in case of dynamic braking failure. The output of the 'No Fault' relay, can be used to operate the mechanical brake through a correct wiring.

The following image shows where the power (plates) and control terminals are located:

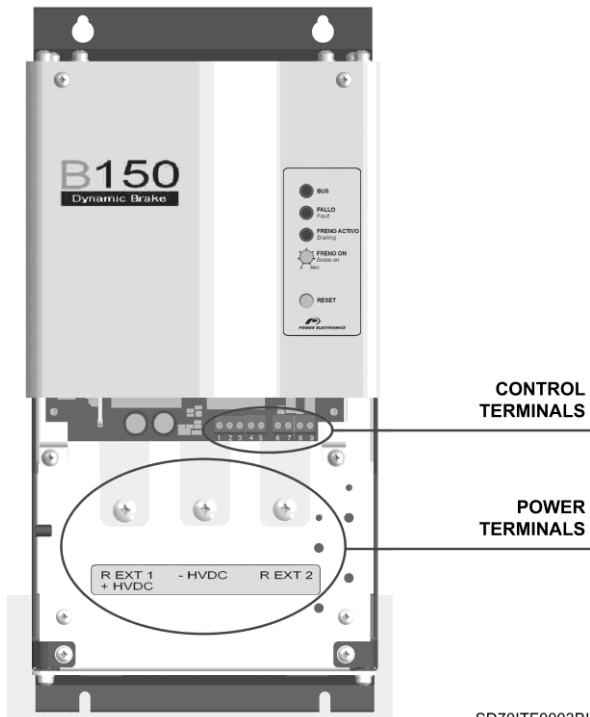

Figure 3.3 Image of the power and control terminals of B150 Unit

3.2.1. Description of Power Terminals for B150 Unit

The access to the power terminals of the B150 unit is from the bottom of the equipment.

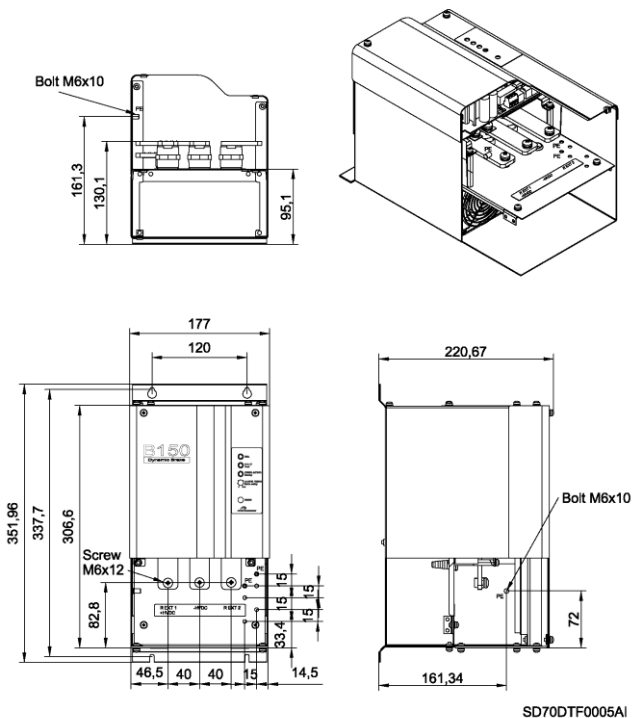



Figure 3.4 Detail of the power terminals of B150 Unit

TERMINAL	DESCRIPTION
R EXT 1 +HVDC	It is connected to the terminal +HVDC of the drive and, at the same time, to one of the terminals of the braking resistor.
-HVDC	It is connected to the terminal –HVDC of the drive.
R EXT 2	It is connected to one of the terminals of the braking resistor.
 (Earth)	It is connected to the earth terminal of the drive.

3.2.2. Description of the Control Terminals for B150 Unit

The control terminals are also accessible from the bottom of the unit.
(See figure 3.3).

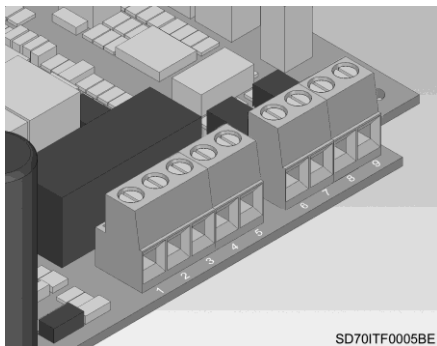
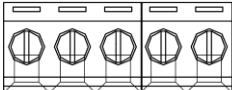

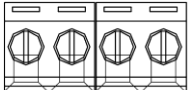



Figure 3.5 Image of the control terminals of B150 Unit

CONNECTOR	DESCRIPTION								
J101	Terminals for Relay 'No Fault'.								
	<table border="1"> <thead> <tr> <th>Terminal</th> <th>Description</th> </tr> </thead> <tbody> <tr> <td>1</td> <td>Output of relay 'No Fault'. NO contact.</td> </tr> <tr> <td>2</td> <td>Output of relay 'No Fault'. Common.</td> </tr> <tr> <td>3</td> <td>Output of relay 'No Fault'. NC contact.</td> </tr> </tbody> </table>	Terminal	Description	1	Output of relay 'No Fault'. NO contact.	2	Output of relay 'No Fault'. Common.	3	Output of relay 'No Fault'. NC contact.
	Terminal	Description							
	1	Output of relay 'No Fault'. NO contact.							
2	Output of relay 'No Fault'. Common.								
3	Output of relay 'No Fault'. NC contact.								
J403	Connection terminals of digital input for External Fault control.								
	<table border="1"> <thead> <tr> <th>Terminal</th> <th>Description</th> </tr> </thead> <tbody> <tr> <td>4</td> <td rowspan="2">Connection for signal of thermal sensor of the braking resistor (if the resistor is equipped with this sensor).</td> </tr> <tr> <td>5</td> </tr> </tbody> </table>	Terminal	Description	4	Connection for signal of thermal sensor of the braking resistor (if the resistor is equipped with this sensor).	5			
	Terminal	Description							
4	Connection for signal of thermal sensor of the braking resistor (if the resistor is equipped with this sensor).								
5									
J405	Input connection terminals for braking control in Slave Mode.								
	<table border="1"> <thead> <tr> <th>Terminal</th> <th>Description</th> </tr> </thead> <tbody> <tr> <td>6</td> <td rowspan="2">This connection must be used when the dynamic braking unit is going to operate in Slave Mode. See section 'Operating Mode Setting'.</td> </tr> <tr> <td>7</td> </tr> </tbody> </table>	Terminal	Description	6	This connection must be used when the dynamic braking unit is going to operate in Slave Mode. See section 'Operating Mode Setting'.	7			
	Terminal	Description							
6	This connection must be used when the dynamic braking unit is going to operate in Slave Mode. See section 'Operating Mode Setting'.								
7									
J406	Output connection terminals for connecting other dynamic braking modules in cascade.								
	<table border="1"> <thead> <tr> <th>Terminal</th> <th>Description</th> </tr> </thead> <tbody> <tr> <td>8</td> <td rowspan="2">This connection must be used when other dynamic braking units are going to be connected in cascade, independently of the selected operating mode. See section 'Operating Mode Setting'.</td> </tr> <tr> <td>9</td> </tr> </tbody> </table>	Terminal	Description	8	This connection must be used when other dynamic braking units are going to be connected in cascade, independently of the selected operating mode. See section 'Operating Mode Setting'.	9			
	Terminal	Description							
8	This connection must be used when other dynamic braking units are going to be connected in cascade, independently of the selected operating mode. See section 'Operating Mode Setting'.								
9									
<div style="display: flex; justify-content: space-around; align-items: flex-end;"> <div style="text-align: center;"> <p>J101</p>  <p>1 2 3</p> </div> <div style="text-align: center;"> <p>J403</p>  <p>4 5</p> </div> <div style="text-align: center;"> <p>J405</p>  <p>6 7</p> </div> <div style="text-align: center;"> <p>J406</p>  <p>8 9</p> </div> </div> <p style="text-align: right; margin-right: 100px;">SD70DTF0007BE</p> <p style="text-align: center;"><i>Figure 3.6 Detail of control terminals</i></p>									

3.2.3. Connections between B150 Unit and SD700 Drive

The details of the different configurations to connect the B150 braking unit with the SD700 are described next. It is necessary to consider the requirements of each application to choose the proper connection.



WARNING

Isolate the drive from the power supply before connecting the braking unit to it.

Make sure the power supply has been disconnected and let at least 10 minutes elapse in order to guarantee the DC bus has been discharged, before installing B150 Braking Unit. Otherwise, you may get an electric shock.

It is recommended to use shielded cable to connect all control signals in order to meet EMC compliance. The shielded cables must be correctly connected to earth. It is recommended the control wiring is separated from the power wiring by 300mm.

Connect the terminals of the drive bus **+HVDC** and **-HVDC** to the terminals **+HVDC** and **-HVDC** of the B150 unit, according to the figure 3.6, by using for this, low-inductance unipolar twisted cable cables as shown in figure 3.7. Be careful to observe the correct polarity.

The maximum recommended cable length between the B150 braking unit and the SD700 drives is 2 meters. The maximum recommended cable length between B150 unit and the resistors is 10 meters. The used cables should be a unipolar twisted pair.

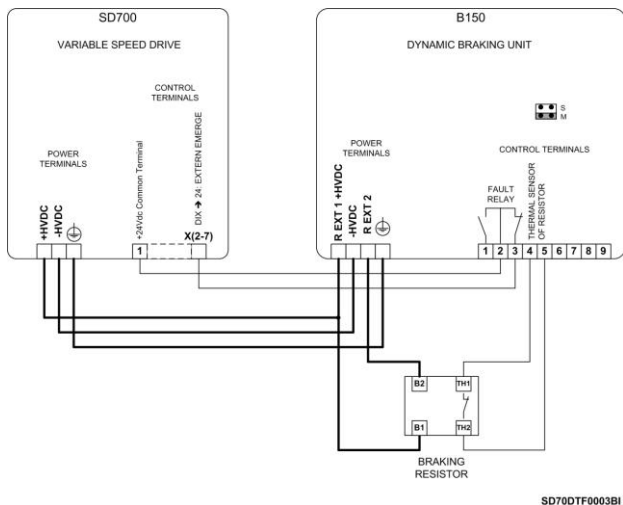

Figure 3.6 Connections between SD700 and Braking Unit B150

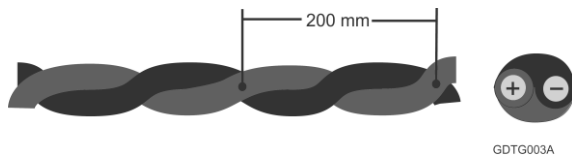

Figure 3.7 Unipolar twisted cable with a turn ratio of 200 mm

3.2.4. Connection of the Braking Resistor

The braking resistors **MUST** be non-inductive. For additional protection of the B150, it is recommended to use fast-acting fuses of proper value.

Due to the high switching speed and the high current of the B150 unit, it must be used unipolar twisted cable with a turn ratio of 200mm (figure 2.7) and a maximum distance of 10m. This would reduce the inductance of the cable.

The braking resistor is connected to the terminals labelled as **R EXT 1** and **R EXT 2** using low inductance cables, as the previous figure shows.

The maximum recommended cable length between the B150 unit and the braking resistors is 10 meters.

The sizing of the cable should be selected by using the Average Brake Resistor Current (I_{AV}) instead of the Peak Current rating in accordance with:

$$I_{AV} = I_{PK} \times D_R$$

Terminals of Braking Resistor

It is recommended to use braking resistors equipped with thermal sensors. Connect it to the terminals 4 and 5 of the B150 braking unit enabled for this purpose. See figure 3.6.

Terminals for braking resistor are the following ones:

TERMINAL	DESCRIPTION
B1, B2	Terminals to connect the resistor to the dynamic braking unit. Connect the terminals of the braking resistor to the terminals R EXT 1 / +HVDC and R EXT 2 of the B150 unit.
TH1, TH2 ^[1]	<p>Thermal sensor of the resistor. The status of which will change according to the temperature.</p> <ul style="list-style-type: none"> - For normal temperature (ambient): Normally closed (NC) (TH1 – TH2 closed contact). - In case of resistor over temperature: Normally open (NO) (TH1 – TH2 open contact). <p>These terminals are connected to the terminals 4 and 5 of the B150 unit. When the contact is open by over temperature, the relay 'No Fault' of the B150 is active. To generate a fault in the drive, connect the terminal 1 (NO contact of relay 'No Fault' – closed when fault occurs) of the B150 to one digital input of the drive configured as 'External Fault'.</p>

^[1] Terminals TH1 and TH2 will be available when the used braking resistor is equipped with thermal sensor.

3.3. Operating Mode Setting

There are two operating modes for the dynamic braking unit B150: Master Mode and Slave Mode.

Additionally, two or more braking units can be connected in cascade, independently of the selected operating mode and according to the application requirements.

3.3.1. Master Mode Selection

In this mode, the brake is auto-controlled. For this:

- Select Master Mode through the jumper M.

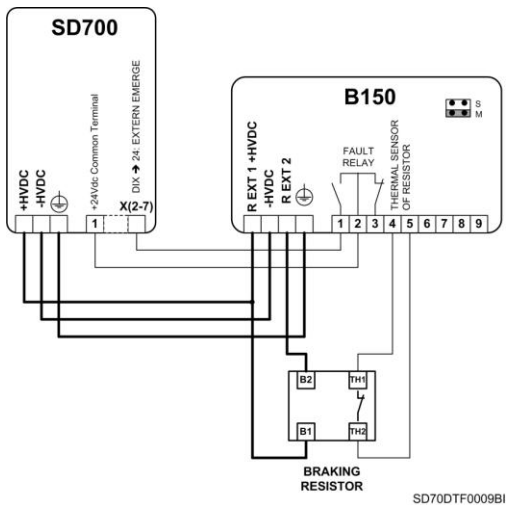

Figure 3.8 Connections between SD700 and Braking Unit B150 – Master Mode

To connect more braking units in cascade:

- The first unit is configured in Master Mode, and the remaining brakes are configured in Slave Mode. For this, the jumper S must be connected (see section 'Slave Mode Selection').
- Connect the pin 8 of the master brake connector to the pin 6 of the connectors of all slave brakes.
- Connect the pin 9 of the master brake connector to the pin 7 of the connectors of all slave brakes.

Note: Regarding the power connections, connect the terminals **+HVDC** and **-HVDC** of the SD700 drive to the terminals **R EXT 1 +HVDC** and **-HVDC** respectively of all used braking units B150. Also, the ground terminals must be connected between them. See following figure.

3.3.2. Slave Mode Selection

In order to the braking unit can operate in Slave Mode, it must connect **the optional board for braking unit in slave mode SD7DB** to the SD700 drive. The information referred to this board is detailed in the Annexe A of this manual.

In this mode, the brake is controlled by the drive. For this:

- Select Slave Mode through the jumper S.
- Connect the pin 1 of the optional board for braking unit in slave mode, which is connected to J201 of the control board of the drive, to the pin 7 of the braking unit connector. Also, connect the pin 2 of the optional board to the pin 6 of the braking unit.

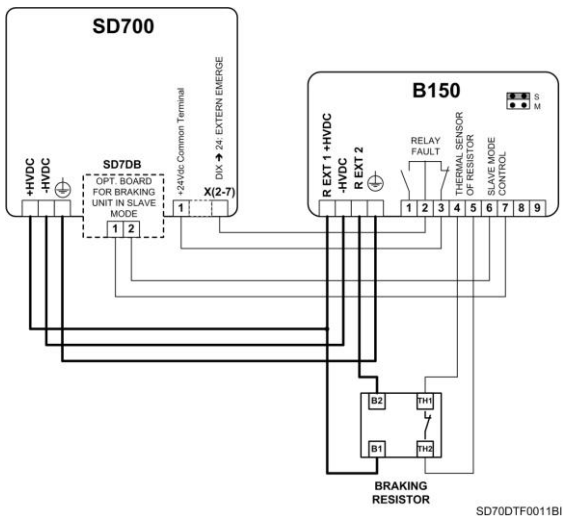

Figure 3.10 Connections between SD700 and Braking Unit B150 – Slave Mode

To connect more braking units in cascade:

- Configure in slave mode the remaining braking units by connecting the jumper S in all brakes.
- Connect the pin 8 of the connector of the slave brake which is controlled by the drive (dominant slave) to the pin 6 of the connectors of all remaining slave brakes.
- Connect the pin 9 of the connector of the slave brake controlled by the drive (dominant slave) to the pin 7 of the connectors of all remaining slave brakes.

Note: Regarding the power connections, connect the terminals **+HVDC** and **-HVDC** of the SD700 drive to the terminals **R EXT 1 +HVDC** and **-HVDC** respectively of all used braking units B150. Also, the ground terminals must be connected between them. See following figure.

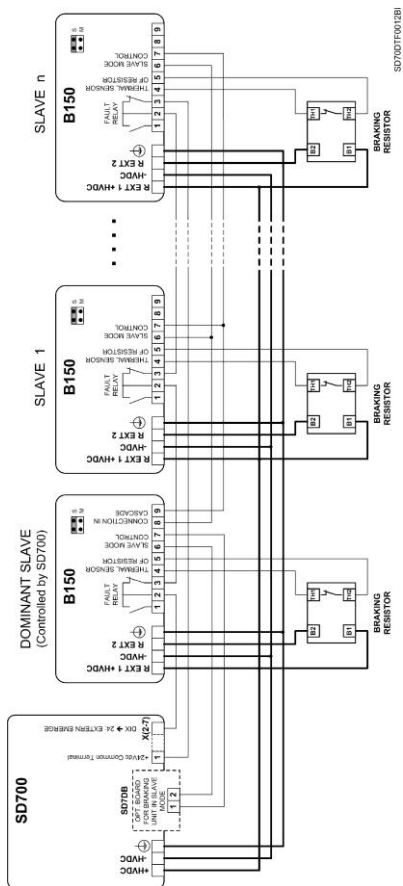
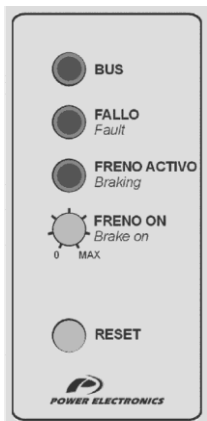

Figure 3.11 Connection B150 in Slave Mode – Connection of brakes in cascade

3.4. Local Settings and Indications

The B150 braking unit has several leds located in front side of the equipment. They provide user with information about the operating status of the braking unit. Below them, there are a potentiometer for the setting of the activating voltage of the brake and a reset push-button.



SD701TF0004BE

Figure 3.11 Local settings and indications

ELEMENT	DESCRIPTION
Led BUS	Lit when power supply is connected to the Dynamic Braking unit.
Led FALLO <i>Fault</i>	Lit when a fault occurs.
Led FRENO ACTIVO <i>Braking</i>	Lit when the resistor is active.
Potentiometer FRENO ON <i>Brake ON</i>	Fine-setting potentiometer. Allows setting the activating voltage level of the brake. The higher is the setting, the more effective is the brake, but is nearer to the trip level. It is recommended to set to high values and reduce them according to the application, avoiding that the drive trips by overvoltage.
Push-button RESET	Fault reset. Allows resetting the faults and leaving the unit ready to operate whenever the causes which generate the fault have been solved.

3.5. Safety Connection for ‘No Fault’ Relay

The safety relay ‘No Fault’ is active during normal operation and no active when the power is removed or a fault occurs.

The B150 unit has protections from:

- Desaturation of the IGBT
- Over temperature of the heat sink

If the B150 unit trips out for any reason, the dynamic braking effect will be lost. Under this circumstance, certain loads may require an additional or a safety mechanical braking.

Alternatively, the safety relay ‘No Fault’ of the B150 unit may be used as a signal for the SD700 drives which indicates External Fault. See connection drawing for additional information.

3.6. Mounting of the Dynamic Braking Resistor

Careful considerations must be given to the mounting of dynamic brake resistors. These devices are able to dissipate large amounts of power and will often reach high temperatures. It is recommended that the resistors are provided with sufficient cool air, so this, the hot air generated does not affect to neither braking unit nor to the drive.

3.7. Resistor Thermal Protection

A failure of the B150 unit may cause the resistors to be turned ON permanently (open circuit). Unless preventive actions are taken, the power generated can easily lead to the destruction of low duty cycle resistors or fire.

Additionally, a wrong-calibrated thermal model will not protect a resistor properly. As a result, the braking resistors can be damaged, causing loss of control of the motor, and possibly a fire hazard.

To prevent such events, it is advisable to provide additional over-temperature protection such as thermal fuses or a latching type microtherm mounted near the resistor.

The microtherm should be connected in series with the safety relay 'No Fault' of B150 unit and with the signal of External Fault of the SD700 Series.

Thermal fuses or thermostats fitted to the resistors and connected to the coil of a contactor in the AC motor variable speed drive will provide a second level of protection.

Better protection is possible by also controlling a DC contactor connected in series with the dynamic braking resistor. This also provides protection in case of the B150 unit failing and permanently switching on. The resistor contactor must be DC rated, NEVER replace it by an AC rated contactor.

4. RECOMMENDATIONS FOR APPLICATIONS

One of the most common applications for the B150 is to aid in the rapid deceleration of loads that have a high level of inertia (for example, large fans or centrifuges pumps).

In this application type, when the drive begins to decelerate the load, the slip speed of the motor can become negative. This causes the motor to regenerate energy charging the DC Bus capacitors, increasing the DC Bus voltage. The dynamic braking unit is turned on when the DC Bus voltage reaches a preset level.

The B150 unit has the ability to monitor the DC Bus voltage directly by using an internal voltage sensor Master Control Mode. When the B150 is turned on, the dynamic braking resistor is connected through the DC Bus, thus dissipating the regenerated energy and controlling the DC Bus voltage at the same time.

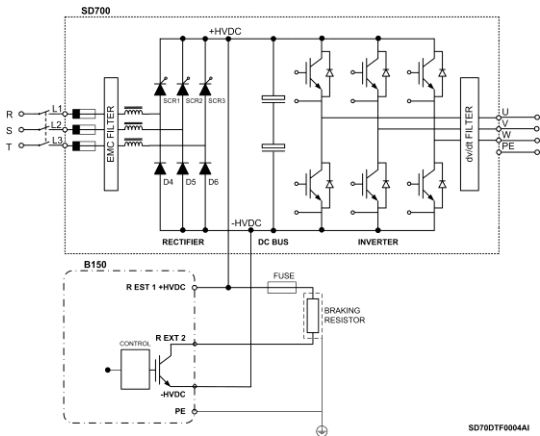

Figure 4.1 Configuration of Dynamic Braking System

The effect of this action is that the mechanical energy in the load, which is reflected back into the DC Bus, is converted to heat in the braking resistor and the control of the motor deceleration is maintained.

If the level of the regeneration exceeds the capability of the dynamic braking system the DC Bus voltage will continue to increase. This will cause that the drive will trip by high voltage in DC Bus (F2).

This is an undesirable situation and should be rectified by decreasing the resistor value and calculating properly the power of the resistor.

4.1. Selection of the Dynamic Braking Resistor

The external resistor MUST be of non-inductive construction.

To select the appropriate power rating and thermal capacity of the dynamic braking resistor, certain requirements must be determined and calculated. If it is required information about these calculations for the resistors and wiring requirements, please, request assistance from Power Electronics or its authorized distributors.

4.1.1. Peak Instantaneous Regenerated Power (P_{GPK})

This is the absolute maximum peak power generated from the load that must be absorbed by the dynamic braking resistor. This value is used to determine the minimum resistance of the dynamic braking resistor. Therefore, select a dynamic braking resistor with a Peak Power rating (P_{RPK}) greater than the Peak Instantaneous Regenerated Power (P_{GPK}).

Otherwise, do not select a dynamic braking resistor such that the B150 maximum switch current of 300A is exceeded.

4.1.2. Short Term Average Regenerated Power (P_{GVA})

This is the average power generated by the load over a short term repetitive cycle. Ensure that the resistor has a continuous power rating greater than the Short Term Average Regenerated Power (P_{GVA}) of the load.

4.1.3. The Dynamic Braking Resistor Duty Rating (D_R)

The allowable short term dynamic brake Duty Rating (D_R) of the dynamic braking resistor must be known for the correct protection of the resistor. This value will be required when commissioning the B150 unit.

The allowable short term dynamic brake Duty Rating (D_R) can be calculated from the following equation:

$$D_R = \frac{P_{GPK}}{P_{GAV}} \cdot 100\%$$

The actual braking resistor Average Dissipated Power (P_{RAV}) is:

$$P_{RAV} = \frac{P_{GPK} \cdot D_R}{100\%}$$

5. PARAMETER SETTING FOR SD700 SERIES

In the SD700, there is a parameter which must be configured when the use of an external dynamic braking unit is required. This parameter is included in group G17.

5.1. Group 17 – G17: Brake

Parameter	Description	Range	Default value	Function	Set on RUN	
5 DYN BRAK=N	G17.5/ Use of External Brake	N Y	N	User must configure the drive if an external dynamic brake is going to be used.	YES	
				OPT.		FUNCTION
				N=NO		External brake is not used.
Y=YES	External brake is going to be installed.					

6. TROUBLESHOOTING AND MAINTENANCE

Description of the possible faults, breakdowns and problems, and possible solutions. Basic instructions for overall maintenance.

6.1. Troubleshooting

It is recommended to connect the thermal sensor of the resistor to the B150 unit, additionally the external relay should be connected to the SD700 drive and configured as an external fault. That way any B150 failure will cause an emergency stop in the drive.

The possible displayed failures are:

Failure	Possible cause and solution
F EXT External fault	Possible IGBT overheating due a greater duty cycle than expected or deficient cooling. Wait until the equipment cools down, disconnect the equipment and clean the heat sink and fan. Then connect again the equipment and reset the system.
	Possible Resistor overheating due a greater duty cycle or a deficient cooling. Wait until the resistor cools down, clean its surface and reset the system.
	Possible IGBT desaturation. Verify that the resistor ohmic value is correct, otherwise consult Power Electronics.
F 2 Overvoltage	Possible inadequate resistor ohmic value. Verify the value, otherwise consult Power Electronics.
	Possible high DC voltage. Check the B150 status, if it is faulty check the causes of External fault. Otherwise consult Power Electronics.
F Desaturation	Check the B150 status, if it is faulty check the causes of External fault. Otherwise consult Power Electronics.

6.2. Maintenance

Before beginning maintenance tasks, ensure the drive and the dynamic braking unit are completely disconnected, discharged and out of service.

It is recommended to check the heat sink of the B150 unit periodically and, if it is required, clean it with compressed air in order to prevent the obstruction of the slots. It is also recommended to clean with compressed air the braking resistor, once it is guaranteed that the resistor is cold.

In cases where the braking system is installed in high-pollution environments, it is recommended to realize the maintenance tasks more often.

Check and ensure the cooling fan of the B150 unit operates correctly and any alien substance is obstructed it.

It is recommended to check the torque of the power connections a week after the start-up then annually.

7. ANNEX A. OPTIONAL BOARD FOR BRAKING UNIT ON SLAVE MODE

The optional board for the dynamic braking SD7DB, has the function of activating the dynamic braking unit, considering the measurement of the DC Bus Voltage done by the control board of the drive.

This optional board converts the dynamic braking unit B150 into one slave unit of the drive.

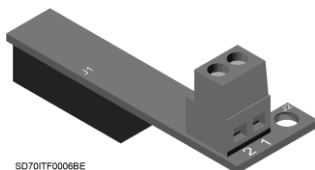

Figure 7.1 Optional board SD7DB

This optional board is provided with two connectors: J1 and J2. As it shown in the following figure, the connector J1 is used to insert the optional board in the control board of the drive through the connector J201.

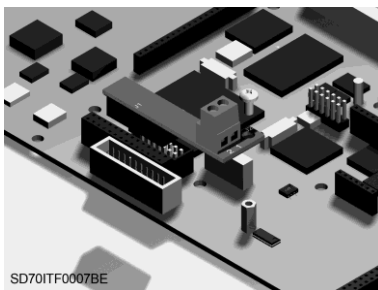

Figure 7.2 Optional board for dynamic braking in slave mode

The connector J2 offers to the user the terminals that must be wired to the connector J405 of the dynamic braking unit.

As has already explained, pin 1 of J2 must be wired with pin 7 of J405. The pin 2 of J2 must be connected with pin 6 of J405.

**POWER ELECTRONICS®**www.powerelectronics.es | www.power-electronics.com

24 Hours Technical Assistance 365 days a year

+34 96 136 65 57

HEADQUARTER • VALENCIA • SPAIN

C/ Leonardo da Vinci, 24 – 26 • Parque Tecnológico • 46980 – PATERNA • VALENCIA • ESPAÑA

Tel. 902 40 20 70 • Tel. (+34) 96 136 65 57 • Fax (+34) 96 131 82 01

BRANCHES

CATALONIA	BARCELONA • Avda. de la Ferreria, 86-88 • 08110 • MONTCADA I REIXAC Tel. (+34) 96 136 65 57 • Fax (+34) 93 564 47 52
	LLEIDA • C/ Terrasa, 13 • Bajo • 25005 • LLEIDA Tel. (+34) 97 372 59 52 • Fax (+34) 97 372 59 52
CANARY ISLANDS	LAS PALMAS • C/ Juan de la Cierva, 4 • 35200 • TELDE Tel. (+34) 928 68 26 47 • Fax (+34) 928 68 26 47
LEVANT	VALENCIA • Leonardo da Vinci, 24-26 • Parque tecnológico • 46980 • PATERNA Tel. (+34) 96 136 65 57 • Fax (+34) 96 131 82 01
	CASTELLON • C/ Juan Bautista Poeta • 2º Piso • Puerta 4 • 12006 • CASTELLON Tel. (+34) 96 136 65 57
	MURCIA • Pol. Residencial Santa Ana • Avda. Venecia, 17 • 30319 • CARTAGENA Tel. (+34) 96 853 51 94 • Fax (+34) 96 812 66 23
NORTH	VIZCAYA • Parque de Actividades • Empresariales Asuarán • Edificio Asúa, 1º B • Ctra. Bilbao • Plencia • 48950 • ERANDIO • Tel. (+34) 96 136 65 57 • Fax (+34) 94 431 79 08
CENTRE	MADRID • Avda. Rey Juan Carlos I, 98, 4º C • 28916 • LEGANES Tel. (+34) 96 136 65 57 • Fax (+34) 91 687 53 84
SOUTH	SEVILLA • C/Arquitectura, Bloque 6 • Planta 5ª • Módulo 2 • Parque Empresarial Nuevo Torneo • 41015 • SEVILLA • Tel. (+34) 95 451 57 73 • Fax (+34) 95 451 57 73
INTERNATIONAL SUBSIDIARIES	
GERMANY	Power Electronics Deutschland GmbH • Dieselstrasse, 77 • D-90441 • NÜRNBERG • GERMANY • Tel. (+49) 911 99 43 99 0 • Fax (+49) 911 99 43 99 8
AUSTRALIA	Power Electronics Australia Pty Ltd • U6, 30-34 Octal St, Yatala, • BRISBANE, QUEENSLAND 4207 • P.O. Box 6022, Yatala DC, Yatala Qld 4207 • AUSTRALIA • Tel. (+61) 7 3386 1993 • Fax (+61) 7 3386 1993
BRAZIL	Power Electronics Brazil Ltda • Av. Imperatriz Leopoldina, 263 – conjunto 25 • CEP 09770-271 • SÃO BERNARDO DO CAMPO - SP • BRASIL • Tel. (+55) 11 5891 9612 • Tel. (+55) 11 5891 9762
CHILE	Power Electronics Chile Ltda • Los Productores # 4439 – Huechuraba • SANTIAGO • CHILE • Tel. (+56) (2) 244 0308 • 0327 • 0335 • Fax (+56) (2) 244 0395 Oficina Petronila # 246, Casa 19 • ANTOFAGASTA • CHILE • Tel. (+56) (55) 793 965
CHINA	Power Electronics Beijing • Room 606, Yiheng Building • No 28 East Road, Beisanhuan • 100013, Chaoyang District • BEIJING • R.P. CHINA Tel. (+86 10) 6437 9197 • Fax (+86 10) 6437 9181 Power Electronics Asia Ltd • 20/F Winbase Centre • 208 Queen's Road Central • HONG KONG • R.P. CHINA
KOREA	Power Electronics Asia HQ Co • Room #305, SK Hub Primo Building • 953-1, Dokok-dong, Gangnam-gu • 135-270 • SEOUL • KOREA Tel. (+82) 2 3462 4656 • Fax (+82) 2 3462 4657
INDIA	Power Electronics India • No 25/4, Palaami Center, • New Natham Road (Near Ramakrishna Mutt), • 625014 • MADURAI Tel. (+91) 452 452 2125 • Fax (+91) 452 452 2125
ITALY	Power Electronics Italia Srl • Piazzale Cadorna, 6 • 20123 • MILANO • ITALIA Tel. (+39) 347 39 74 792
MEXICO	P.E. Internacional Mexico S de RL • Calle Cerrada de José Vasconcelos, No 9 • Colonia Tlalnepantla Centro • Tlalnepantla de Baz • CP 54000 • ESTADO DE MEXICO Tel. (+52) 55 5390 8818 • Tel. (+52) 55 5390 8363 • Tel. (+52) 55 5390 8195
NEW ZEALAND	Power Electronics New Zealand Ltd • 12A Opawa Road, Waltham • CHRISTCHURCH 8023 • P.O. Box 1269 CHRISTCHURCH 8140 Tel. (+64 3) 379 98 26 • Fax (+64 3) 379 98 27



www.power-electronics.com