

**SSD Parvex SAS**

8, avenue du Lac - B.P. 249

F-21007 Dijon Cedex

www.SSDdrives.com



PARVEX

## **DIGIVEX Single Motion**

**DIGITAL SERVOAMPLIFIER**

**User and commissioning manual**

**PVD 3515 GB – 04/2004**

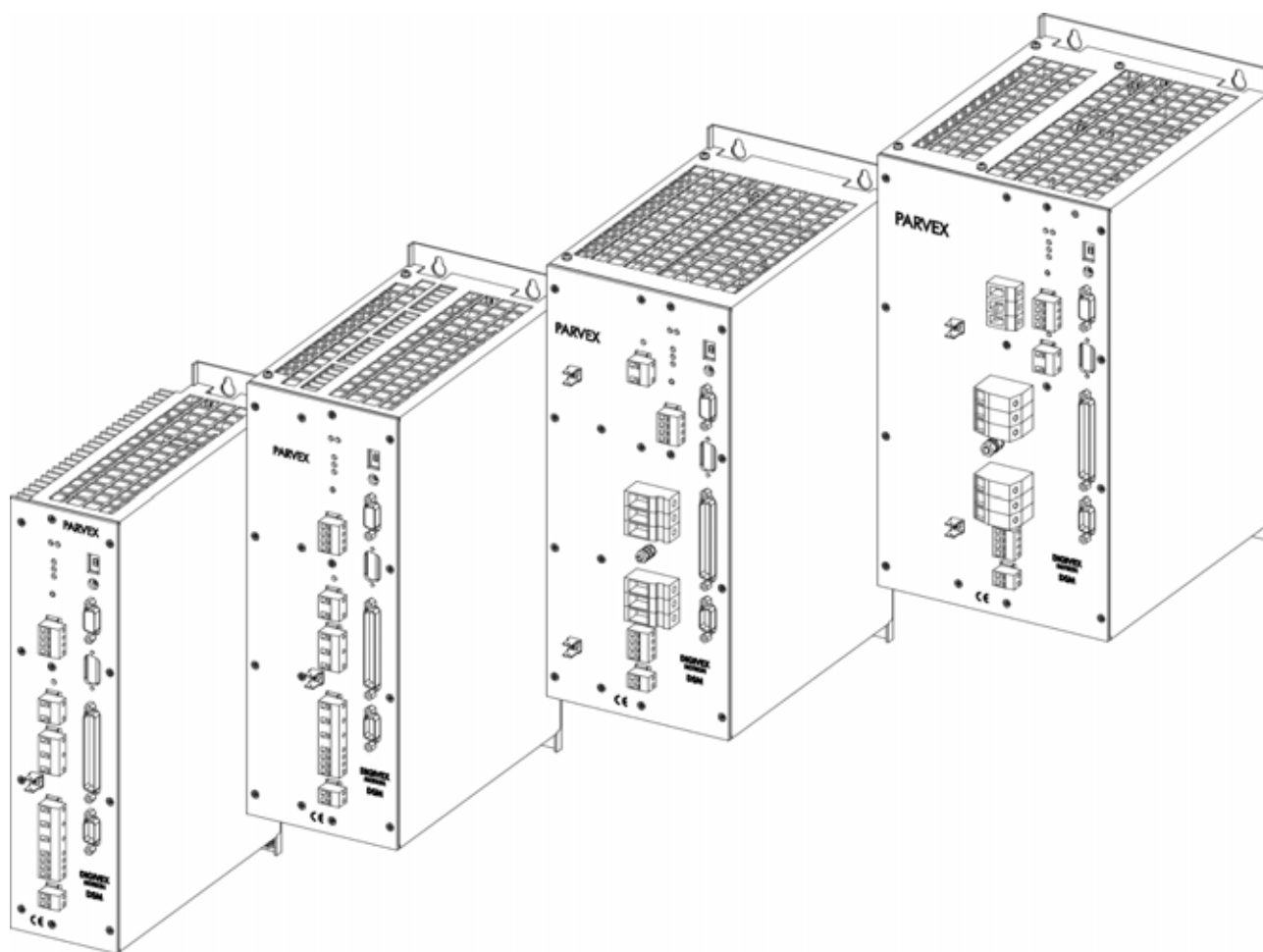

# PRODUCT RANGE

## 1 - « BRUSHLESS » SERVODRIVES

### TORQUE OR POWER RANGES

- **BRUSHLESS SERVOMOTORS, LOW INERTIA, WITH RESOLVER**  
 Very high torque/inertia ratio (high dynamic performance machinery):
  - ⇒ NX -HX - HXA 1 to 320 N.m
  - ⇒ NX - LX 0.45 to 64 N.m
 High rotor inertia for better inertia load matching:
  - ⇒ HS - LS 3,3 to 31 N.m
 Varied geometrical choice :
  - ⇒ short motors range HS - LS 3,3 to 31 N.m
  - ⇒ or small diameter motors : HD, LD 9 to 100 N.m
 Voltages to suit different mains supplies :
  - ⇒ 230V three-phase for «série L - NX»
  - ⇒ 400V, 460V three-phase for «série H - NX»
- **"DIGIVEX Drive" DIGITAL SERVOAMPLIFIERS**
  - ⇒ SINGLE-AXIS DSD
  - ⇒ COMPACT SINGLE-AXIS D $\mu$ D, DLD
  - ⇒ POWER SINGLE-AXIS DPD
  - ⇒ MULTIPLE-AXIS DMD
- "PARVEX Motion Explorer" ADJUSTING SOFTWARE

## 2 - SPINDLE DRIVES

- **SPINDLE SYNCHRONOUS MOTORS**
  - ⇒ "HV" COMPACT SERIES
  - ⇒ "HW" ELECTROSPINDLE, frameless, water-cooled motor From 5 to 110 kW  
up to 60,000 rpm
- **"DIGIVEX" DIGITAL SERVOAMPLIFIERS**

## 3 - DC SERVODRIVES

- **"AXEM", "RS" SERIES SERVOMOTORS** 0.08 to 13 N.m
- **"RTS" SERVOAMPLIFIERS**
- **"RTE" SERVOAMPLIFIERS** for DC motors + resolver giving position measurement

## 4 - SPECIAL ADAPTATION SERVODRIVES

- **"EX" SERVOMOTORS** for explosive atmosphere
- **"AXL" COMPACT SERIES SERVOREDUCTERS** 5 to 700 N.m

## 5 - POSITIONING SYSTEMS

- **Numerical Controls « CYBER 4000 »** 1 to 4 axes
- **"CYBER 2000" NC** 1 to 2 axes
- **VARIABLE SPEED DRIVE - POSITIONER**
  - ⇒ SINGLE-AXIS DSM
  - ⇒ POWER SINGLE-AXIS DPM
  - ⇒ MULTIPLE-AXIS DMM
- **ADJUSTMENT AND PROGRAMMING SOFTWARE** PARVEX Motion Explorer

## CONTENTS

<b>SAFETY INSTRUCTIONS</b> .....	<b>4</b>
<b>PRODUCT RANGE</b>	<b>2</b>
<b>1. GENERAL PRESENTATION</b>	<b>7</b>
1.1 List of published DIGIVEX Motion manuals	7
1.2 DIGIVEX Single Motion general concepts	7
1.3 System components	8
<b>2. GENERAL CHARACTERISTICS</b>	<b>10</b>
2.1 Mains supply characteristics	10
2.2 Modules with 230 V single-phase power supply	11
2.3 Modules with 230 V three-phase power supply	11
2.4 Modules with 400 V three-phase power supply	12
2.5 General characteristics of the DSM	13
<b>3. COMPLIANCE WITH STANDARDS</b>	<b>14</b>
<b>4. ENERGY DISSIPATION</b>	<b>15</b>
4.1 Calculating the power to be dissipated in the braking resistor	15
4.2 Braking energy dissipation	15
4.3 Braking capacity and module losses.	16
<b>5. DIMENSIONS, ASSEMBLY, MASS, LABELLING, CODING</b>	<b>18</b>
5.1 Dimensions, Assembly and Mass	18
5.2 Labelling and Coding	25
5.3 Front Panel, Description of Terminal Blocks and Sub-D Connector	26
5.3.1 Description of terminal blocks and sockets	26
5.3.2 Description of 7-segment display and LEDs	26
5.3.3 Rotary mini-switch setting (ADDRESS)	27
5.3.4 Diagrams	27
5.4 Accessories	32
5.4.1 Input mains filter	32
5.4.2 Inductors for long cable lengths with axis motor	32
5.4.3 External braking resistor	32
<b>6. ELECTRICAL CONNECTIONS</b>	<b>39</b>

<b>6.1</b>	<b>General Wiring Requirements</b>	<b>39</b>
6.1.1	Appliance handling	39
6.1.2	Electromagnetic compatibility	39
6.1.3	DSM Sub-D connectors	40
<b>6.2</b>	<b>Mains connection and relaying</b>	<b>41</b>
6.2.1	Supply current and fuses	41
6.2.1.1	Terminal block B3	41
6.2.1.2	one single drive	41
6.2.1.3	several drives in parallel	42
6.2.2	Standard Connection Diagram	42
6.2.3	Surge Suppressor	49
6.2.4	Earth connection (front panel Faston tab)	50
6.2.5	Auxiliary power supply	50
6.2.5.1	Description	50
6.2.5.2	Terminal block B4	50
6.2.6	Automatic control Input / Output connection	51
6.2.6.1	RESET and Contactor Control	51
6.2.6.2	Terminal block B5	52
<b>6.3</b>	<b>Motor end connection</b>	<b>52</b>
6.3.1	Terminal block B2	52
6.3.2	Motor Power connection	53
6.3.3	Terminal block connection	53
6.3.4	Power connector connection	54
6.3.5	Power cable definition	55
6.3.6	Guidelines for the use of long cables	57
6.3.7	Holding brake connection	62
6.3.8	Thermal protection connection	62
6.3.9	Motor fan connection	62
<b>6.4</b>	<b>Resolver connection</b>	<b>63</b>
6.4.1	Description	63
6.4.2	Sub-D connector X4:"Resolver"	64
6.4.3	Cables	64
<b>6.5</b>	<b>FIELDBUS Connections</b>	<b>66</b>
6.5.1	SUB-D X1 plug : FIELDBUS	66
6.5.2	CANopen connections and cables	66
6.5.3	Profibus connections and cables	66
<b>6.6</b>	<b>Input/Output connection</b>	<b>67</b>
6.6.1	SUB-D X2 socket: Inputs/Outputs	67
6.6.2	Input/Output characteristics	68
6.6.2.1	Logic outputs (out0 - out7)	68
6.6.2.2	Analogue output (outa)	68
6.6.2.3	Logic inputs (in0 - in 15)	69

6.6.2.4	Analogue input (ina)	70
6.6.3	Cable	70
<b>6.7</b>	<b>Encoder emulation option connection (SC6639)</b>	<b>72</b>
6.7.1	Description	72
6.7.2	Sub-D connector X3: encoder emulation option	72
6.7.3	Programming resolution and zero mark position	73
6.7.4	Electrical characteristics	73
6.7.5	Cable	75
<b>6.8</b>	<b>External encoder input option connection (SC6638)</b>	<b>77</b>
6.8.1	Description	77
6.8.2	SUB-D X3 sockets: encoder input option	78
6.8.3	Cable	78
<b>6.9</b>	<b>Connecting the SinCos encoder input option (SC6645)</b>	<b>82</b>
6.9.1	Description	82
6.9.2	SUB-D X3 plug: Encoder input option.	83
6.9.3	Cables	83
<b>6.10</b>	<b>External braking resistor connection</b>	<b>85</b>
6.10.1	Description	85
6.10.2	Terminal block B6	85
<b>6.11</b>	<b>Brake supply connection</b>	<b>86</b>
6.11.1	Description	86
6.11.2	Terminal block B1	86

## **7. COMMISSIONING - DIAGNOSTICS** **87**

<b>7.1</b>	<b>Start-up Sequence</b>	<b>87</b>
7.1.1	Preliminary checks	87
7.1.2	Commissioning with PME-DIGIVEX Motion	87
<b>7.2</b>	<b>Initialization Sequence</b>	<b>87</b>
<b>7.3</b>	<b>Stop Sequence</b>	<b>88</b>
7.3.1	Normal stoppage	88
7.3.2	Stoppage subsequent to mains supply or braking fault	88
7.3.3	Stoppage subsequent to motor drive fault	88
<b>7.4</b>	<b>Detecting Reasons for Stoppage</b>	<b>89</b>
7.4.1	LED display - power supply function	89
<b>7.5</b>	<b>7-segment display status</b>	<b>90</b>

Characteristics and dimensions subject to change without notice.

**YOUR LOCAL CORRESPONDENT**

**SSD Parvex SAS**  
8 Avenue du Lac / B.P 249 / F-21007 Dijon Cedex  
Tél. : +33 (0)3 80 42 41 40 / Fax : +33 (0)3 80 42 41 23  
[www.SSDdrives.com](http://www.SSDdrives.com)

### SAFETY

Servodrives present two main types of hazard :

#### - Electrical hazard

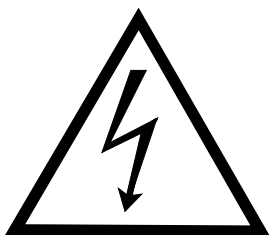

Servoamplifiers may contain non-insulated live AC or DC components. Users are advised to guard against access to live parts before installing the equipment.

Even after the electrical panel is de-energized, voltages may be present for more than a minute, until the power capacitors have had time to discharge.

Specific features of the installation need to be studied to prevent any accidental contact with live components :

- Connector lug protection ;
- Correctly fitted protection and earthing features ;
- Workplace insulation (enclosure insulation humidity, etc.).

#### General recommendations :

- Check the bonding circuit;
- Lock the electrical cabinets;
- Use standardised equipment.



#### - Mechanical hazard

Servomotors can accelerate in milliseconds. Moving parts must be screened off to prevent operators coming into contact with them. The working procedure must allow the operator to keep well clear of the danger area.

All assembly and commissioning work must be done by **qualified** personnel who are familiar with the safety regulations (e.g. VDE 0105 or accreditation C18510).

**Upon delivery**

All servoamplifiers are thoroughly inspected during manufacture and tested at length before shipment.

- Unpack the servoamplifier carefully and check it is in good condition.
- Also check that data on the manufacturer's plate complies with data on the order acknowledgement.

If equipment has been damaged during transport, the addressee must file a complaint with the carrier by recorded delivery mail within 24 hours.

Caution :

The packaging may contain essential documents or accessories, in particular :

- User Manual,
- Connectors.

**Storage**

Until installed, the servoamplifier must be stored in a dry place safe from sudden temperature changes so condensation cannot form.

**Special instructions for setting up the equipment**

	<b>CAUTION</b>
	<p>For this equipment to work correctly and safely it must be transported, stored, installed and assembled in accordance with this manual and must receive thorough care and attention.</p> <p>Failure to comply with these safety instructions may lead to serious injury or damage.</p> <p>The cards contain components that are sensitive to electrostatic discharges. Before touching a card you must get rid of the static electricity on your body. The simplest way to do this is to touch a conductive object that is connected to earth (e.g. bare metal parts of equipment cabinets or earth pins of plugs).</p>



# 1. GENERAL PRESENTATION

## 1.1 List of published DIGIVEX Motion manuals

---

◆ DIGIVEX Single Motion (DSM) User Manual	(DSM)	PVD3515
◆ DIGIVEX Power Motion (DPM) User Manual	(DPM)	PVD3522
◆ DIGIVEX Multi Motion (DMM) User Manual	(DMM)	PVD3523
◆ DIGIVEX Motion - CANopen		PVD3518
◆ DIGIVEX Motion - Profibus		PVD3554
◆ PME-DIGIVEX Motion Adjustment Manual		PVD3516
◆ DIGIVEX Motion Directory of Variables		PVD3527
◆ DIGIVEX Motion Programming		PVD3517
◆ DIGIVEX Motion - Cam Function		PVD3538
◆ PME Tool kit User and Commissioning Manual		PVD3528
◆ CANopen - CAN Bus Access via CIM03		PVD3533
◆ CANopen - Remote control using PDO messages		PVD3543
◆ "Block Positioning" Application Software		PVD3519
◆ "Fly shear linear cutting" software application		PVD3531
◆ "Rotary blade cutting" software application		PVD3532
◆ Motor user's manuals:		
◆ LX/LS/LD		PVD3407
◆ HX/HS/HD		PVD3490
◆ NX		PVD3535

## 1.2 DIGIVEX Single Motion general concepts

---

"DSM" drives are designed to control H-series (400 V mains supply), "L" series (230 V mains supply) or "NX" series (230 V or 400V mains supply) magnet-type synchronous brushless motors.

They have:

- a power section connected directly to the mains supply
- motor power control
- an internal resistor for discharging braking energy.

They are designed to provide:

- positioning or synchronization functions from,
  - ◆ either the motor resolver,
  - ◆ or an external incremental encoder
- plc-type logic functions
- message or parameter transfers via a CANopen or Profibus field bus.

Parameters specification (current, speed, position) and programming (pseudo BASIC or applicative programs) are done by PC with "PME - DIGIVEX Motion" software (under WINDOWS).

A 7-segment display provides a direct readout of the main drive status.

## 1.3 System components

---

A DSM drive system comprises as a minimum:

- A DSM drive-positioner, with either a 230 V single phase, 230 V three-phase, or 400 V three-phase supply depending on the product number
- A mains filter for compliance with CE requirements
- An H-series (400 V supply), L-series (230 V supply) or NX (230V or 400V supply), brushless motor with a resolver-type position sensor and thermal protective sensor. The motor may be equipped with a brake (see motor code).
- An auxiliary AUX power supply for the regulation section of the DSM,
- A control unit for activating the stored programs via DSM inputs / outputs (contacts, push buttons, and possibly an external plc).

It may also feature:

- Additive chokes located close to the drive between the motor and drive where long cables are used.
- A supplementary resistor for "recovering" braking energy where there is high inertia and short cycles
- An option
  - ◆ "external encoder input" for "master-slave" type operations or for applications requiring position acknowledgement on the machine and not the motor.

OR

- ◆ "encoder emulation output" (with resolution adjustable from 1 to 16,384 marks per revolution).
- Connection cables (supplied by Parvex).

Regulation parameter specification, drive setting and user program entry or modification is done exclusively by PC with PME-DIGIVEX Motion software.

The drives are fitted, depending on the reference, with CANopen (DSMxxxxxC) or Profibus (DSMxxxxxP) communication inputs as standard.

# DIGIVEX Single Motion (DSM) Servoamplifier

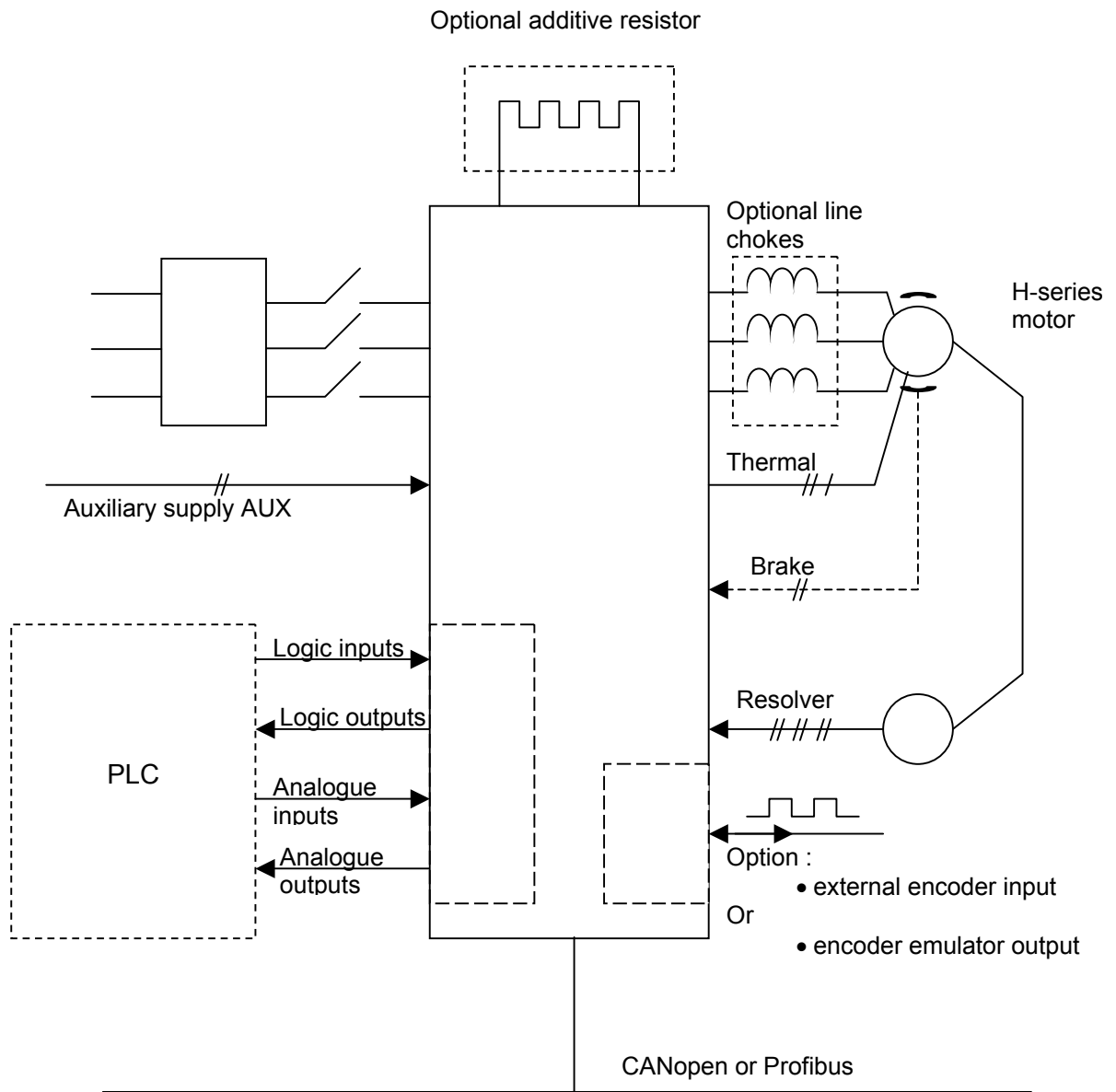

## 2. GENERAL CHARACTERISTICS

### 2.1 Mains supply characteristics

---

#### *230 V single-phase or three-phase modules*

PARAMETER	VALUE
Frequency	48 - 62 Hz
Minimum voltage	100 V rms
Maximum voltage	253V rms
Rated voltage	230V +/- 10%
Dc voltage achieved	140 - 340V

#### *400 V single-phase or three-phase modules*

PARAMETER	VALUE
Frequency	48 - 62 Hz
Minimum voltage	280V rms
Maximum voltage	480V rms
<i>Rated voltage</i>	400V +/- 10%
<i>Dc voltage achieved</i>	380 - 670V

An auto-transformer is required for 480 V rms  $\pm$ 10%.

An external mains filter is necessary for compliance with the requirements on electromagnetic compatibility.

Braking energy is dissipated across the resistor.

Mains monitoring:

- No phase (Except single-phase).
- Overvoltage.

## 2.2 Modules with 230 V single-phase power supply

Input voltage: 230 V  $\pm$ 10%

TYPE	MAINS SUPPLY	CONTROLLABLE POWER	SINE PEAK PERMANENT CURRENT	PEAK MAXIMUM CURRENT	PARVEX PRODUCT NUMBER
<i>DSM 2/4</i>	230 V – single-phase 50/60 Hz	375 W	2 A	4 A	<i>DSM 13M02</i>
<i>DSM 4/8</i>	230 V – single-phase 50/60 Hz	750 W	4 A	8 A	<i>DSM 13M04</i>
<i>DSM 7.5/15</i>	230 V – single-phase 50/60 Hz	1500 W	7.5 A	15 A	<i>DSM 13M07</i>

## 2.3 Modules with 230 V three-phase power supply

Input voltage: 230 V  $\pm$ 10%

TYPE	MAINS SUPPLY	CONTROLLABLE POWER	SINE PEAK PERMANENT CURRENT	PEAK MAXIMUM CURRENT	PARVEX PRODUCT NUMBER
<i>DSM 4/8</i>	230 V – three-phase 50/60 Hz	750 W	4 A	8 A	<i>DSM 13004</i>
<i>DSM 7.5/15</i>	230 V – three-phase 50/60 Hz	1500 W	7.5 A	15 A	<i>DSM 13007</i>
<i>DSM 15/30</i>	230 V – three-phase 50/60 Hz	3000 W	15 A	30 A	<i>DSM 13015</i>
<i>DSM 30/60</i>	230 V – three-phase 50/60 Hz	6000W	30A	60A	<i>DSM 13030</i>
<i>DSM 60/100</i>	230 V – three-phase 50/60 Hz	12000W	60A	100A	<i>DSM 13060</i>

## 2.4 Modules with 400 V three-phase power supply

Input voltage: 400 V  $\pm$ 10%

TYPE	MAINS SUPPLY	CONTROLLABLE POWER	SINE PEAK PERMANENT CURRENT	PEAK MAXIMUM CURRENT	PARVEX PRODUCT NUMBER
<i>DSM 2/4</i>	<i>400 V – three-phase 50/60 Hz</i>	<i>750 W</i>	<i>2 A</i>	<i>4 A</i>	<i>DSM 16002</i>
<i>DSM 4/8</i>	<i>400 V – three-phase 50/60 Hz</i>	<i>1500 W</i>	<i>4 A</i>	<i>8 A</i>	<i>DSM 16004</i>
<i>DSM 8/16</i>	<i>400 V – three-phase 50/60 Hz</i>	<i>3000 W</i>	<i>8 A</i>	<i>16 A</i>	<i>DSM 16008</i>
<i>DSM 16/32</i>	<i>400 V – three-phase 50/60 Hz</i>	<i>6000W</i>	<i>16A</i>	<i>32A</i>	<i>DSM 16016</i>
<i>DSM 32/64</i>	<i>400 V – three-phase 50/60 Hz</i>	<i>12000W</i>	<i>32A</i>	<i>64A</i>	<i>DSM 16032</i>

## 2.5 General characteristics of the DSM

Power reduction with altitude	Above 1000 m, service power falls by 1% for every 100 m up to a maximum altitude of 4000 m
Operating temperature	Normal use: 0 - 40°C Above 40°C, service power fall by 20% for every 10°C up to a maximum temperature of 60°C.
relative humidity	85% (without condensation)
Storage temperature	-30°C to +85°C
Chopping frequency	8 kHz
Current bandwidth	600Hz to -3dB
Speed bandwidth	Up to 60Hz
Maximum speed	Driven by DIGIVEX : 60,000 rpm : 100,000 rpm
Electrical protection	Electrical isolation of power bridge Mean current protection depending on drive rating Pulse current protection of drive and motor rms current protection of motor Protection against short circuits at bridge output
Mechanical protection	IP20 under IEC 529
Other monitoring	Tracking error Motor temperature Drive temperature No resolver Brake supply Limit switches
User programs	FLASH_DM : 512 Kilobyte
Memory sizes	PROG_DM : 256 Kilobyte

Communication bus:

- CANopen: DSMxxxxxC reference positioner drives
- Profibus: DSMxxxxxP reference positioner drives

## 3. COMPLIANCE WITH STANDARDS

### DSM

The CE marking of the product is featured on the front panel (silk-screen printing).

DSM products have the CE marking under European Directive 89/336/EEC as amended by Directive 93/68/EEC on electromagnetic compatibility. This European Directive invokes the harmonized generic standards EN50081-2 of December 1993 (Electromagnetic compatibility - Emission generic standard - Industrial environment) and EN50082-2 of June 1995 (Electromagnetic compatibility - Immunity generic standard - Industrial environment). These two harmonized generic standards are based on the following reference standards:

- EN 55011 of July 1991: Radiated and line conducted emissions.
- ENV 50140 of August 1993 and ENV 50204: Immunity to radiated electromagnetic fields.
- EN 61000-4-8 of February 1994: Power frequency magnetic fields.
- EN 61000-4-2 of June 1995: Electrostatic discharge.
- ENV 50141 of August 1993: Disturbances induced in cables.
- EN 61000-4-4 of June 1995: Rapid transients.

Compliance with the reference standards above implies observance of the wiring instructions and diagrams provided in this documentation.

### Incorporation in a machine

The design of this equipment allows it to be used in a machine subject to Directive 89/392/EEC (Machinery Directive), provided that its integration (or incorporation and/or assembly) is done in accordance with the rules of the art by the machine manufacturer and in accordance with the instructions of this booklet.



## 4. ENERGY DISSIPATION

The energy a module has to dissipate is broken down into:

- Energy generated by braking.
- Energy from rectifier and power bridge losses.

### 4.1 Calculating the power to be dissipated in the braking resistor

The permanent and pulse powers given in the preceding table are limited by the characteristics of the "braking" resistors.

When the application includes intensive cycles or long-duration decelerations, the mean power to be dissipated by each axis must be calculated.

$$P \text{ in Watts} = \frac{J}{2} \left( \frac{N}{9.55} \right)^2 \cdot f$$

J : Moment of inertia of the servomotor and the related load in kgm<sup>2</sup>.

N : Angular speed of motor shaft at start of braking, in rpm.

f : repeat frequency of braking cycles in s<sup>-1</sup>.

This formula is for the least favourable case. For a mechanism with substantial friction or with low reverse output, the power to be dissipated may be greatly reduced.

The total power to be dissipated of all the drives must not exceed the permanent power admissible through the resistor. Durations and repetition must not exceed the values in table §4. 3.

### 4.2 Braking energy dissipation

Braking energy is dissipated through a resistor mounted in the module. The resistor may be mounted externally for DSM 60/100-230 V three-phase and DSM 32/64 - 400 V three-phase models.

*This recuperation is controlled from two thresholds measured on the bus voltage.*

	Threshold Values	
	Braking resistor switched in	Braking resistor switched out
230 V single- or three-phase modules	380 VDC	370 VDC
400 V three-phase modules	710 VDC	690 VDC

### 4.3 Braking capacity and module losses.

- 230 V single-phase or three-phase modules.

		MODULE RATING					
		2/4	4/8	7.5/15	15/30	30/60	60/100
<i>Resistor value</i>	Ω	56	56	56	22	11	7
<i>Maximum current</i>	A	7	7	7	17	34	50
<i>Pulse power</i>	kW	2.2	2.2	2.2	6.0	12	18
<i>Permanent power</i>	W	60	60	60	250	500	700
<i>Maximum non repetitive duration</i>	s	1	1	1	2	2	2
<i>Maximum repeat cycle duration</i>	s	0.1	0.1	0.1	0.2	0.2	0.2
<i>Repetition</i>	%	2.7	2.7	2.7	4.3	4.3	4.3
<i>Losses from modules (at maximum power)</i>	W	15	25	50	100	200	400
<i>Low level consumption</i>	W	10	10	10	15	15	15

- 400 V three-phase modules.

		MODULE RATING				
		2/4	4/8	8/16	16/32	32/64
<i>Resistor value</i>	Ω	220	220	82	41	27
<i>Maximum current</i>	A	3	3	8.5	17	25
<i>Pulse power</i>	kW	2.2	2.2	6	12	18
<i>Permanent power</i>	W	60	60	250	500	700
<i>Maximum non repetitive duration</i>	s	1	1	2	2	2
<i>Maximum repeat cycle duration</i>	s	0.1	0.1	0.2	0.2	0.2
<i>Repetition</i>	%	2.7	2.7	4.3	4.3	4.3
<i>Losses from modules (at maximum power)</i>	W	30	50	100	200	400
<i>Low level consumption</i>	W	10	10	15	15	15

- Definitions

**Maximum current:** maximum current controlled, the resistor switches in at 710 V or 375 V for certain modules, the controlled current is equal at most to 710 or 375 / resistor value.

**Pulse power:** maximum power dissipated by the resistor, this power can only be drawn for a short time and in compliance with a certain cycle.

**Permanent power:** mean power that can be dissipated on a permanent basis by the resistor.

**Non repetitive maximum duration:** maximum duration, in seconds, for which the pulse power can be required (starting from cold); the resistor must be allowed to cool down before braking again.

**Repeat cycle maximum duration:** maximum duration, in seconds, for which the pulse power can be required provided that this power is only present for a certain percentage of the total time (repetition).

**Module losses:** losses specific to the module, the value shown in the table is that obtained when the module is used at maximum power.

**Low-level consumption:** consumption of the low-level power supplies in Watts.

***Specific case of 60/100 - 230 V three-phase and 32/64 -400 V three-phase modules.***

*These two modules can use an external resistor to dissipate braking energy. If this possibility is used, the characteristics obtained are those shown in the table below: with RE91001 resistor for the 32/64 module and RE91002 resistor for the 60/100 module*

		MODULE RATING	
		32/64	60/100 Two resistors In parallel
<i>Resistor value</i>	$\Omega$	27	6
<i>Maximum current</i>	A	26	62
<i>Pulse power</i>	kW	18	23
<i>Permanent power</i>	W	2000	2800
<i>Maximum non repetitive duration</i>	s	5	5
<i>Maximum repeat cycle duration</i>	s	0.5	0.5
<i>Repetition</i>	%	12	12

## **5. DIMENSIONS, ASSEMBLY, MASS, LABELLING, CODING**

### **5.1 Dimensions, Assembly and Mass**

---

See the following pages, drawing numbers - FELX 305844  
- FELX 305845  
- FELX 305847  
- FELX 305849  
- FELX 305846  
- FELX 305848

# DIGIVEX Single Motion (DSM) Servoamplifier

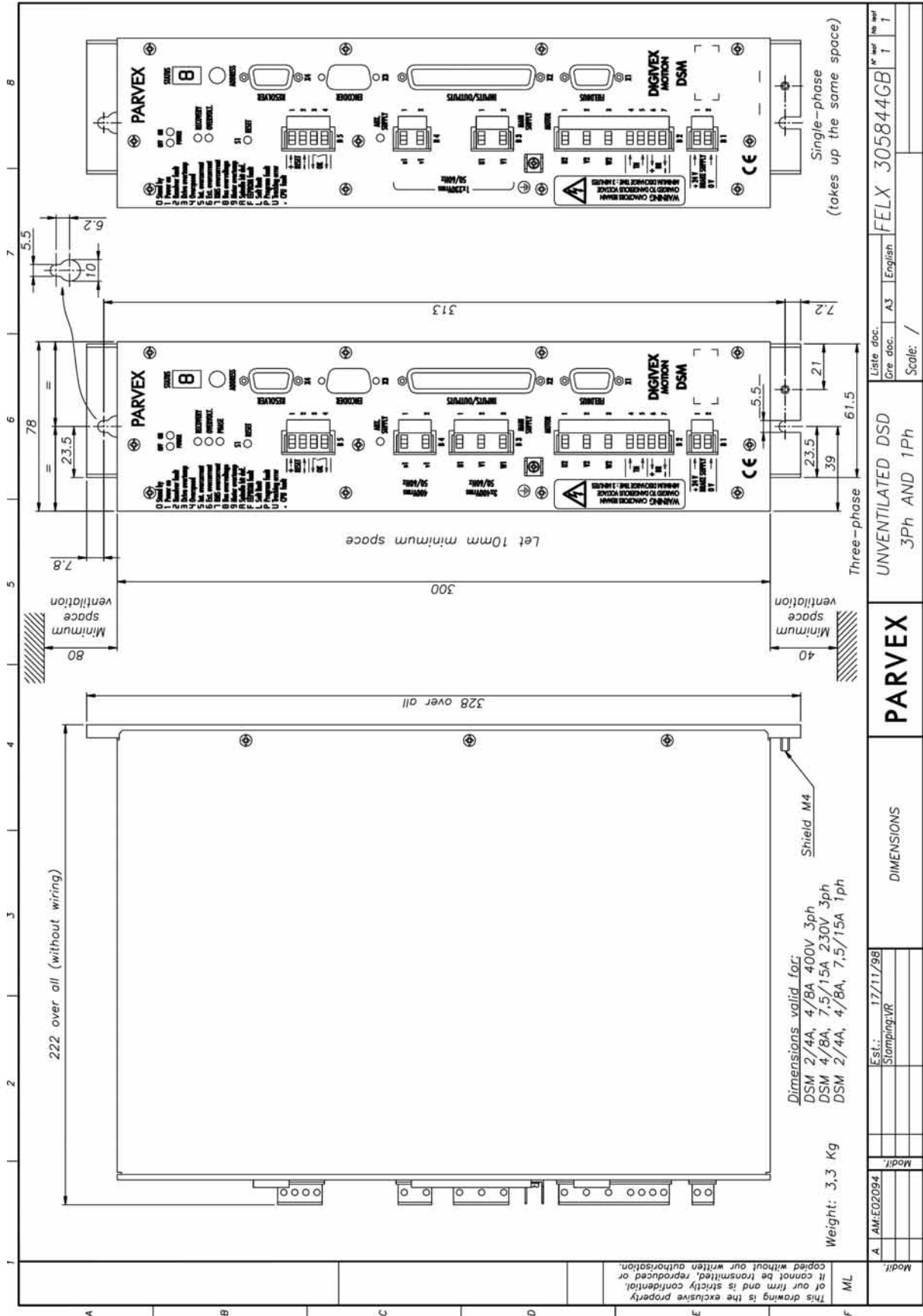

# DIGIVEX Single Motion (DSM) Servoamplifier

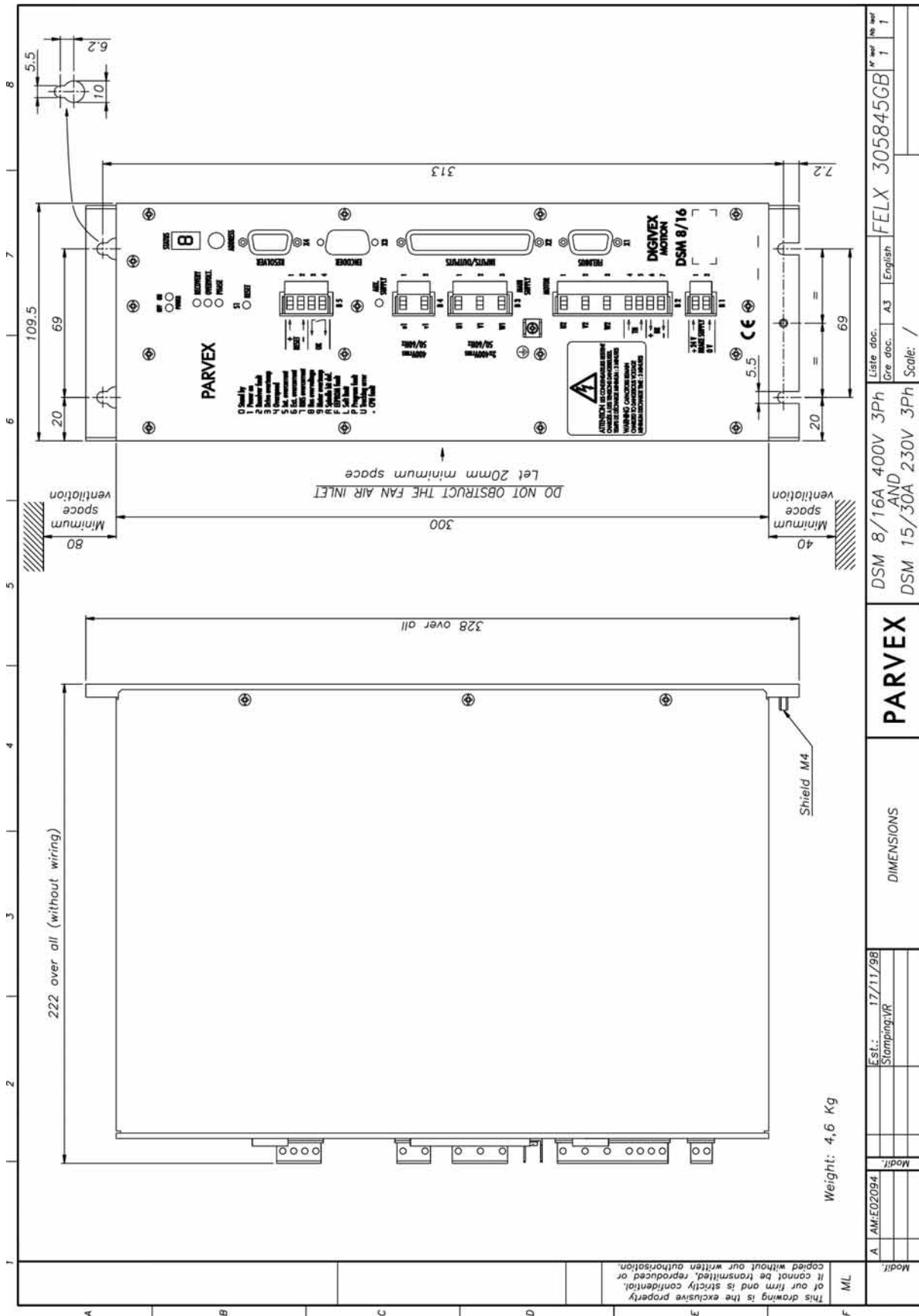

# DIGIVEX Single Motion (DSM) Servoamplifier

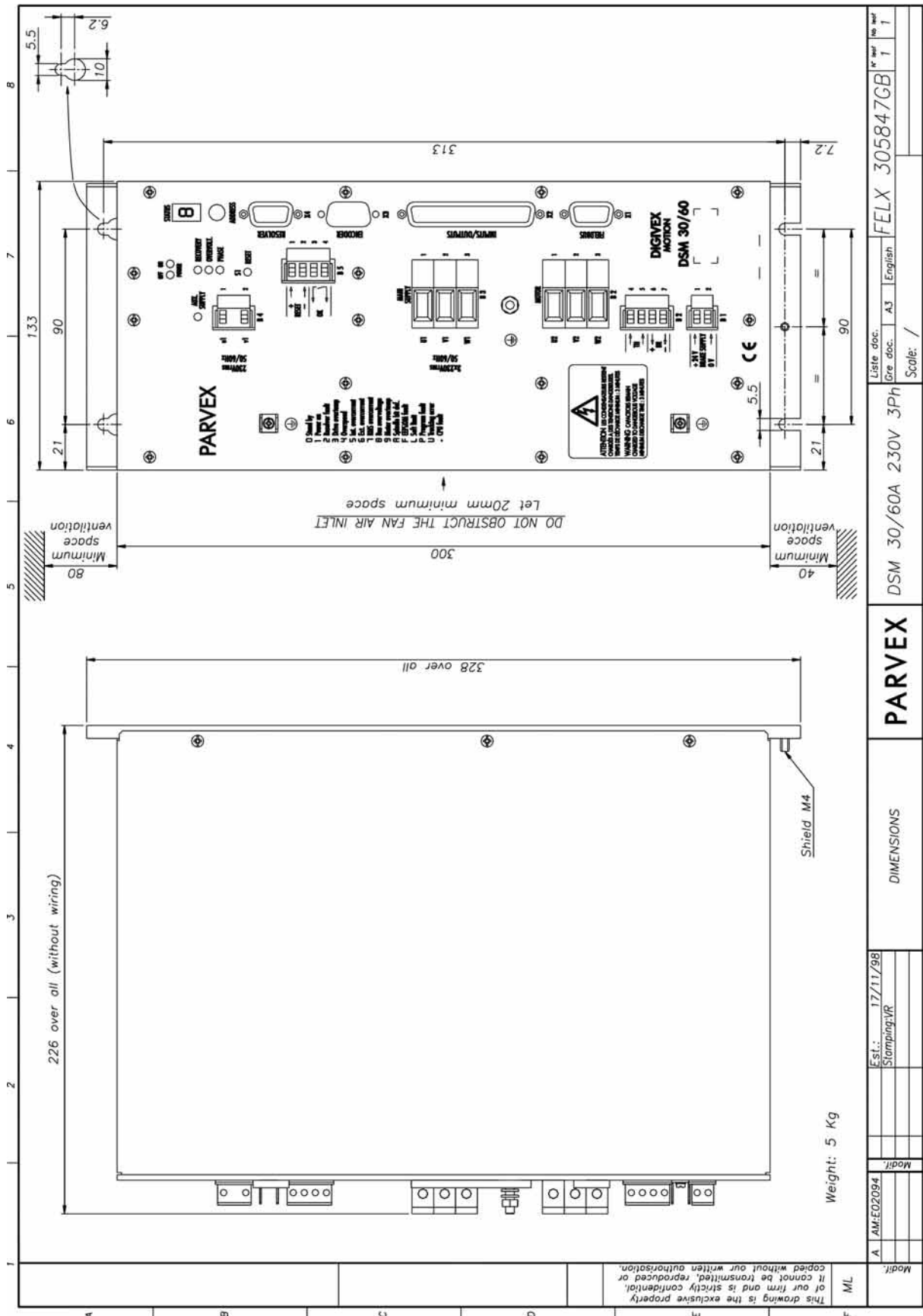

# DIGIVEX Single Motion (DSM) Servoamplifier

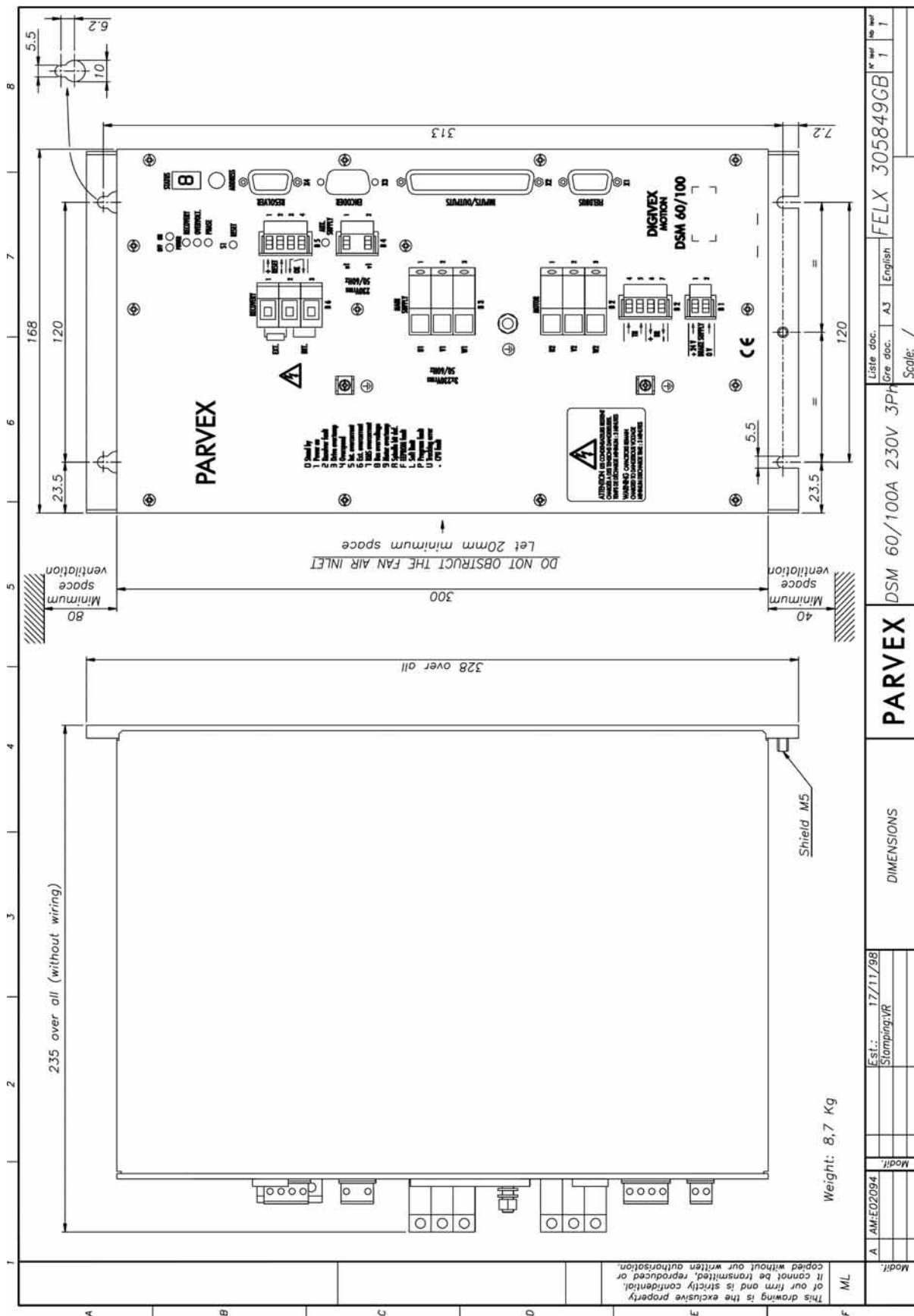

Modif.	A	AMEFO2094	Modif.	
Est.	17/11/98	Stamping/VR		
DIMENSIONS		<b>PARVEX</b>	DSM 60/100A 230V 3PH	FELX 305849GB
			Gre. doc. A3 English	Scale: /
			Liste doc.	

This drawing is the exclusive property of our firm and is strictly confidential. It cannot be transmitted, reproduced, copied without our written authorization.



# DIGIVEX Single Motion (DSM) Servoamplifier

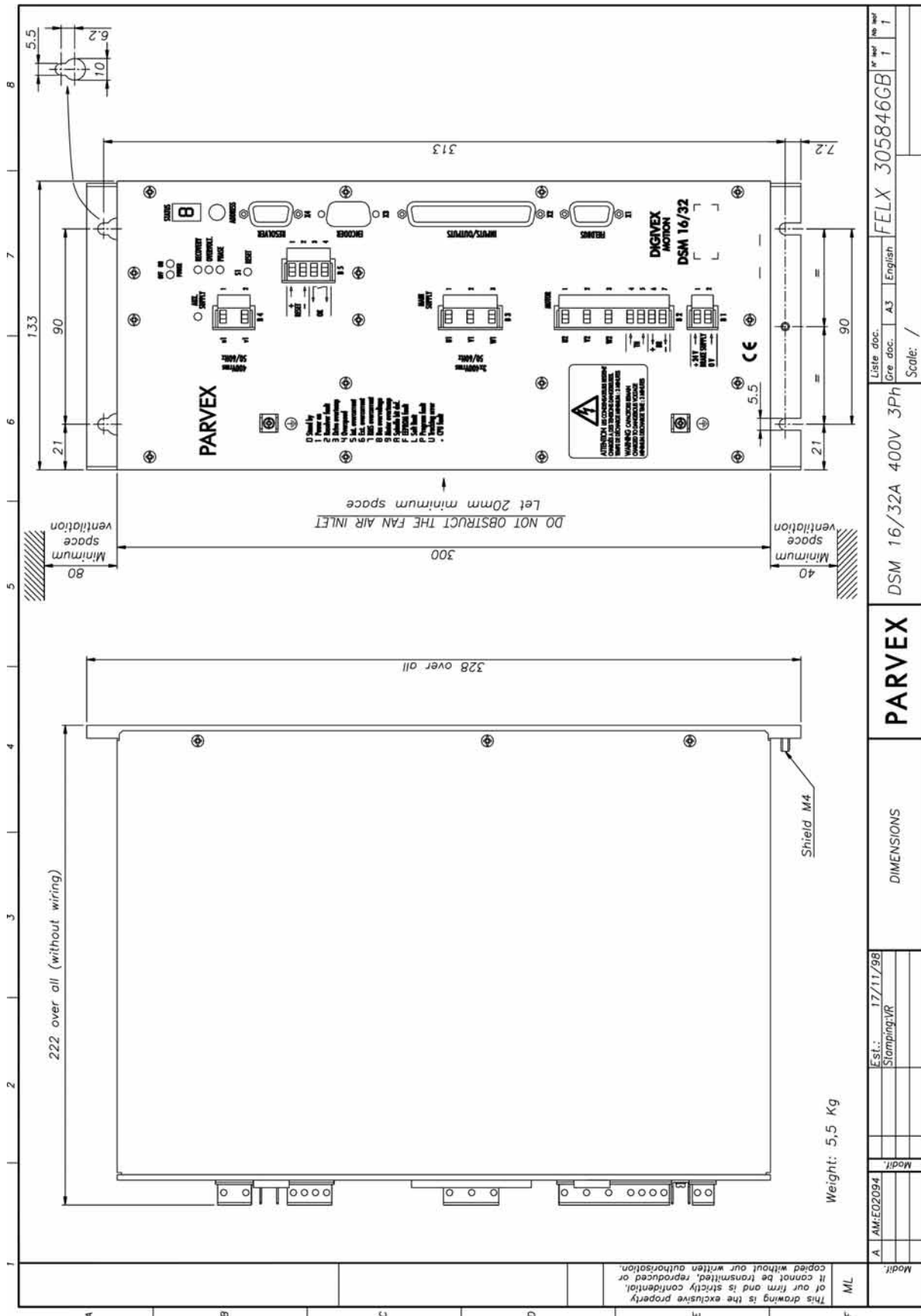

Modif.	A	AM/E02094	Modif.	
		Stamping:VR		
		17/11/98		
DIMENSIONS			<b>PARVEX</b>	
DSM 16/32A 400V 3Ph			Gr. doc.	A3
			English	
			Scale: /	
			FELX 305846GB	

# DIGIVEX Single Motion (DSM) Servoamplifier

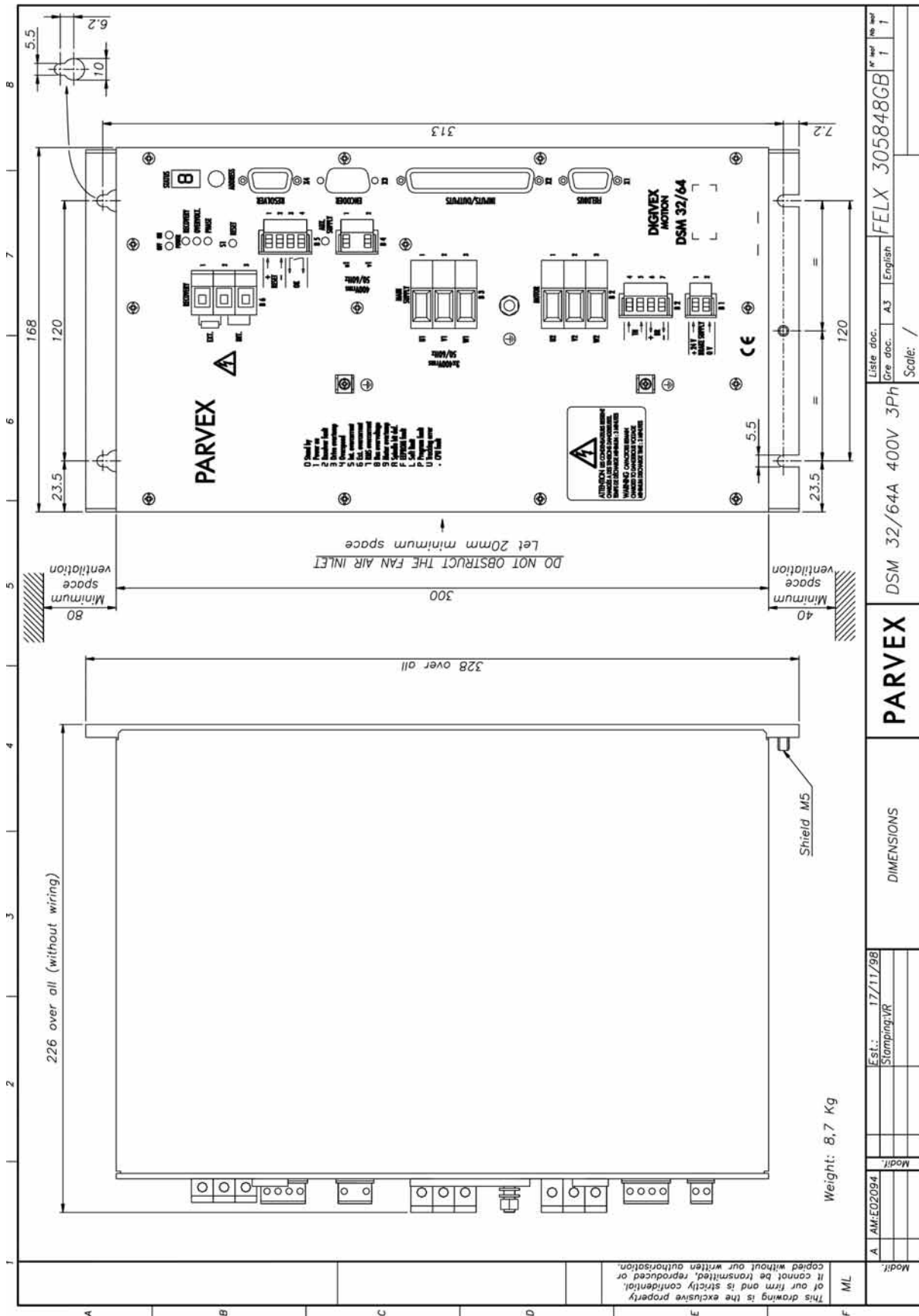

## 5.2 Labelling and Coding

Physical identification by label:

- On DSM :
  - \* One label plate fixed to the appliance as in the model below:

CONVERTISSEUR CA/CA          DSM13007 E: 3x230V    4,8A                  S: 0-310V    î=7,5A Fn: 50/60Hz    Classe 1        MADE IN FRANCE
--------------------------------------------------------------------------------------------------------------------------------------------------

Meaning of label indications:

- CA/CA converter            : Alternating current converter
- DSM - - - - -                : DSM servo-amplifier code
- E : 3 X - - - -V    --A        : Input voltage and current
- fn : --/--Hz                 : Frequency
- S: 0- - - -V    î=--Â        : Output voltage and permanent output current (Amps. Peak)
- Classe -                      : Service class under standard NF EN60146, 1= permanent
- Serial number and date of manufacture

Drive customization parameters are recorded in a plug-in EEPROM. They can only be read via a PC with PME DIGIVEX Motion software.

### Codification

CODE	FUNCTION
DSM13M02-	DSM 230V single-phase 2/4 A
DSM13M04-	DSM 230V single-phase 4/8 A
DSM13M07-	DSM 230V single-phase 7.5/15 A
DSM13004-	DSM 230V three-phase 4/8 A
DSM13007-	DSM 230V three-phase 7.5/15 A
DSM13015-	DSM 230V three-phase 15/30 A
DSM13030-	DSM 230V three-phase 30/60 A
DSM13060-	DSM 230V three-phase 60/100 A
DSM16002-	DSM 400V three-phase 2/4 A
DSM16004-	DSM 400V three-phase 4/8 A
DSM16008-	DSM 400V three-phase 8/16 A
DSM16016-	DSM 400V three-phase 16/32 A
DSM16032-	DSM 400V three-phase 32/64 A

DSMxxxxxC : DSM with CANopen fieldbus interface

DSMxxxxxP : DSM with Profibus fieldbus interface

## 5.3 Front Panel, Description of Terminal Blocks and Sub-D Connector

### 5.3.1 Description of terminal blocks and sockets

All the input/outputs required for operation are arranged on the front panel in the form of:

- B1 brake supply terminal block.
- B2 motor terminal blocks (in 1 or 2 parts depending on rating).
- B3 power supply terminal block.
- B4 auxiliary power supply terminal block.
- B5 terminal block for automatic control connection.
- B6 terminal block for external resistor connection on DSM 32/64 and DSM 60/100 ratings.

Connectors with metal-plated or metallic covers.

ITEM REF.	CONNECTOR TYPE (cable end)	FUNCTION	MAX. CONDUCTOR CROSS-SECTION
X1 FIELDBUS	9-pin plug for soldering	Fieldbus connection	max. 0.5 mm <sup>2</sup> on soldering barrel
X2 INPUTS/ OUTPUTS	37-pin plug for soldering	Logic and analog inputs / output	max. 0.5 mm <sup>2</sup> on soldering barrel
X3 ENCODER	9-pin plug if encoder emulator output	Encoder emulation output (option)	max. 0.5 mm <sup>2</sup> on soldering barrel
	9-pin socket for soldering	Incremental encoder input	
X4 RESOLVER	9-pin socket for soldering	Resolver link	max. 0.5 mm <sup>2</sup> on soldering barrel

The motor earth is to be connected to the Faston earth lug on the appliance. The SUB-D plugs used must be metal-coated (or metal) and provide continuous shielding through to the appliance's metal earth.

### 5.3.2 Description of 7-segment display and LEDs

- A 7-segment "STATUS" display shows the drive operating status.
- A green "POWER ON" LED indicates the auxiliary supply and power supply are on.
- A "POWER OFF" red LED indicates there is no power supply.
- A "RECOVERY" red LED indicates the recovery resistor is operating.
- An "OVERVOLT." red LED indicates excess mains or bus voltage.
- A "PHASE" red LED indicates no mains phase (three-phase appliances only).
- An "AUX SUPPLY" red LED indicates the auxiliary supply is present.

### 5.3.3 Rotary mini-switch setting (ADDRESS)

Each appliance in the same network CAN or Profibus must have a different subscriber number.

A rotating, 16-position, mini-switch is used to define the number of the appliance.

For information:

0	Prohibited
1	1*
2	2*
3	3
.	.
.	.
.	.
.	.
A	10
B	11
C	12
D	13
E	14
F	15

\* The “1” and “2” addresses are prohibited to the Profibus bus

The subscriber code may be extended. Please ask for details.

**Attention!** For a subscriber number change to be acknowledged, the appliance must be switched off completely for a few seconds.

### 5.3.4 Diagrams

- 230 V single-phase DSM 2/4A, 4/8A, 7.5/15A
- 230 V three-phase DSM 4/8A, 7.5/15A
- 230 V three-phase DSM 15/30A
- 230 V three-phase DSM 30/60A
- 230 V three-phase DSM 60/100A
- 400 V three-phase DSM 2/4A, 4/8A,
- 400 V three-phase DSM 8/16A
- 400 V three-phase DSM 16/32A
- 400 V three-phase DSM 32/64A

# DIGIVEX Single Motion (DSM) Servoamplifier

230V Single-phase 2/4  
4/8A, 7.5/15A

230V Three-phases 4/8A,  
7.5/15A

230V Three-phases 15/30A

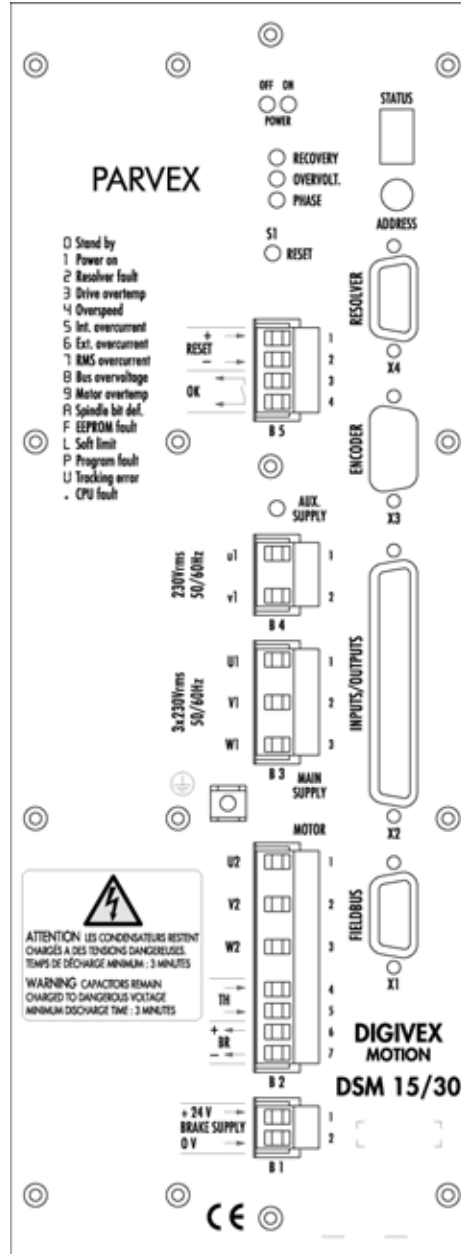
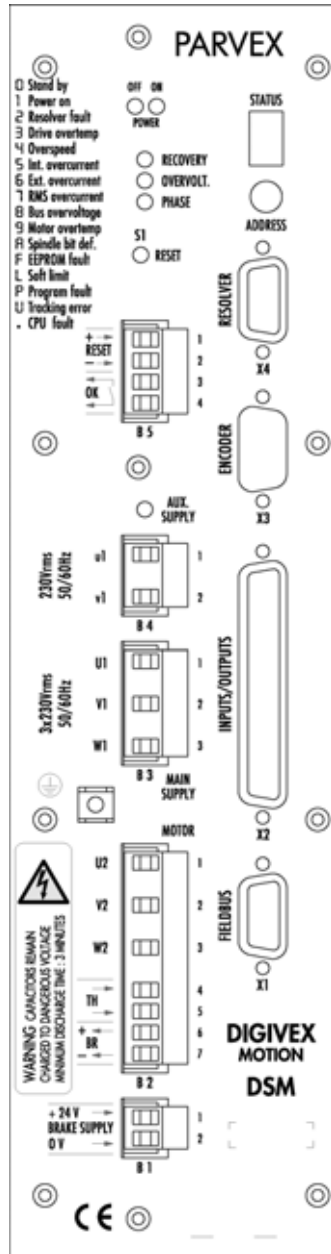
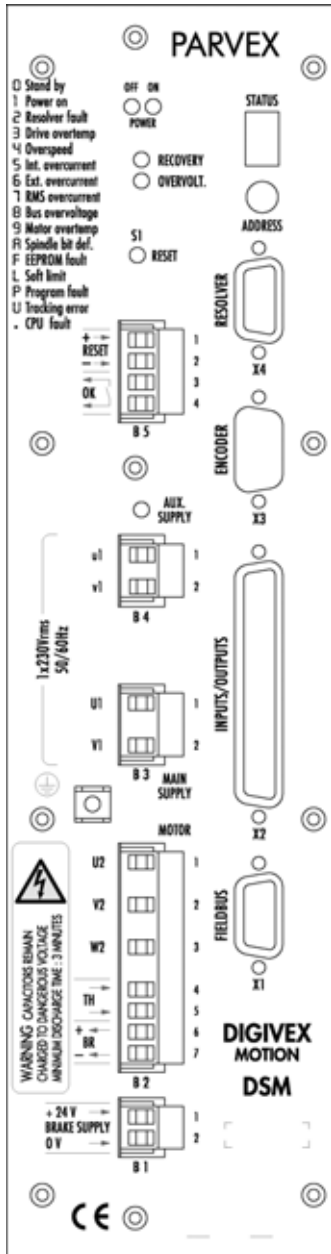

# DIGIVEX Single Motion (DSM) Servoamplifier

230V Three-phases 30/60A

230V Three-phases 60/100A

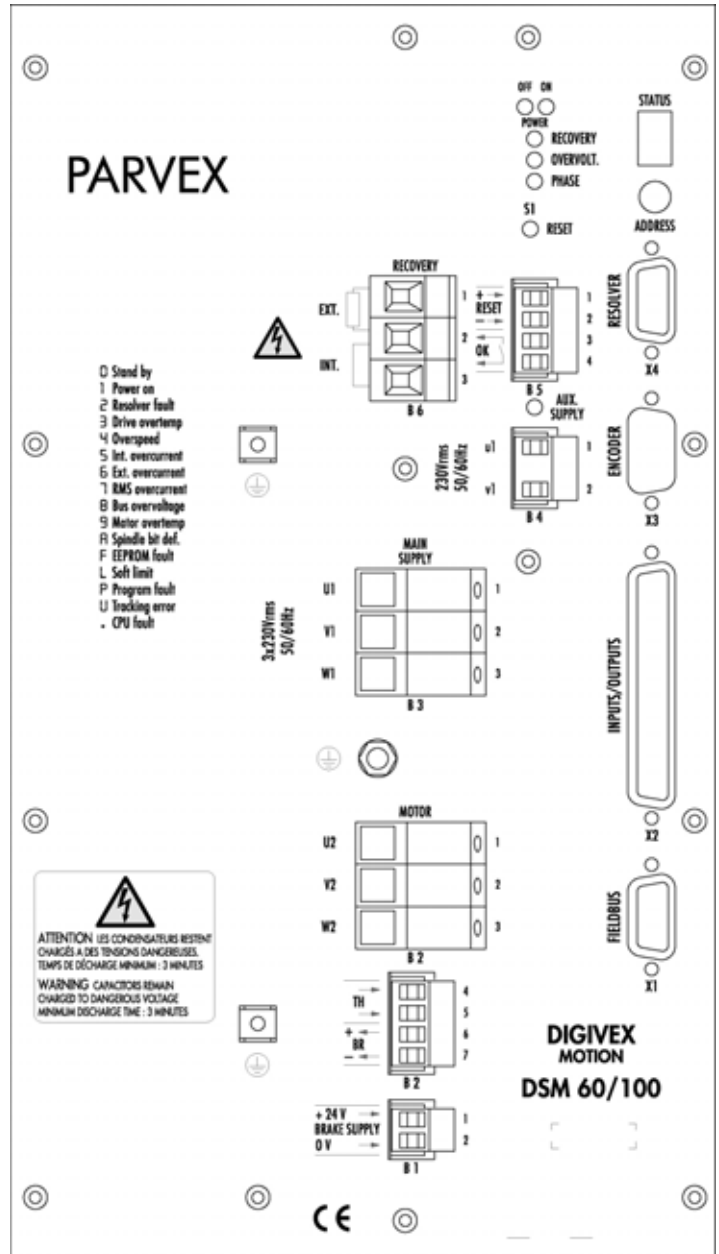
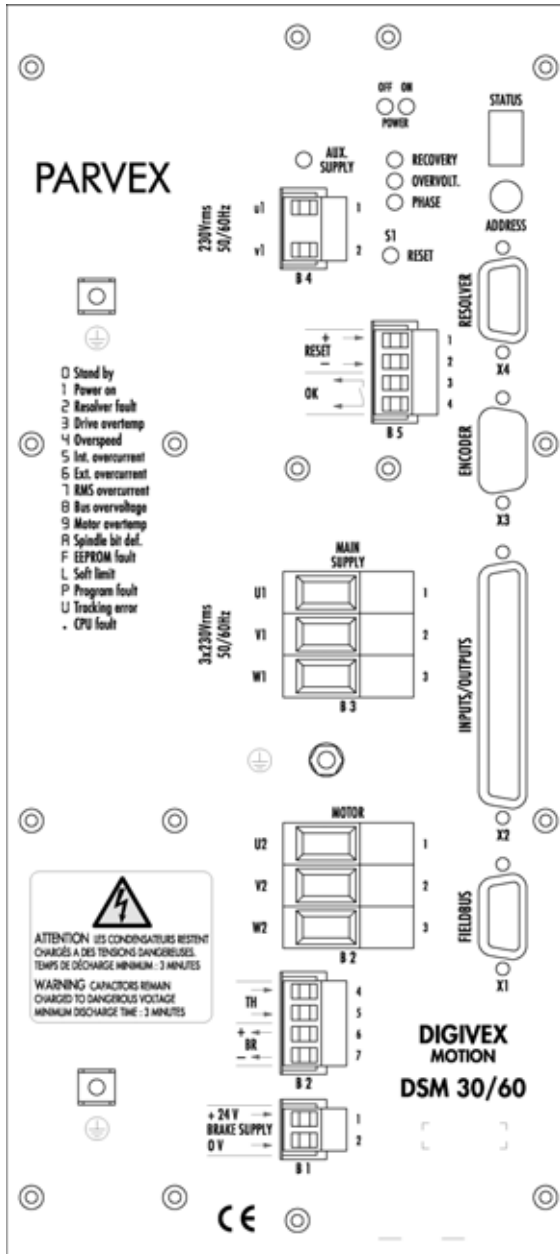

# DIGIVEX Single Motion (DSM) Servoamplifier

400V Three-phases 2/4A, 4/8A

400V Three-phases 8/16A

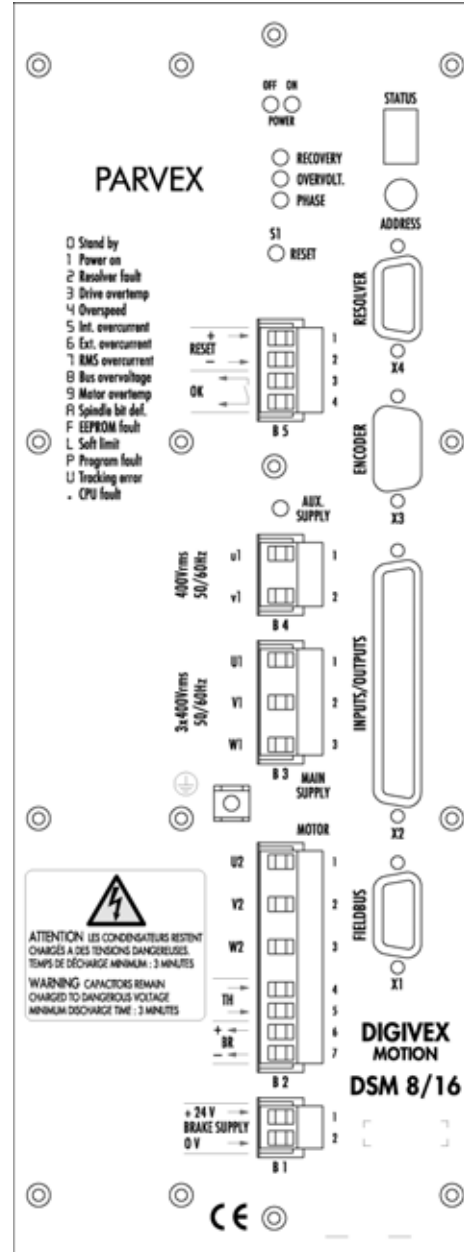
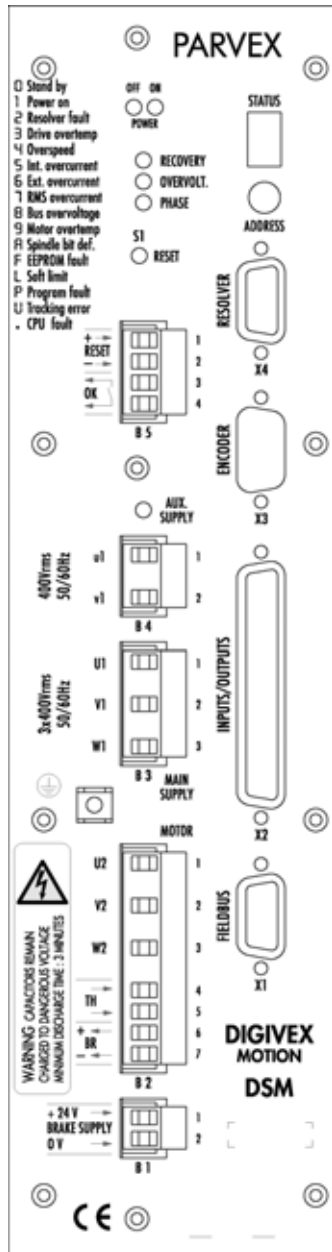



# DIGIVEX Single Motion (DSM) Servoamplifier

400V Three-phases 16/32A

400V Three-phases 32/64A

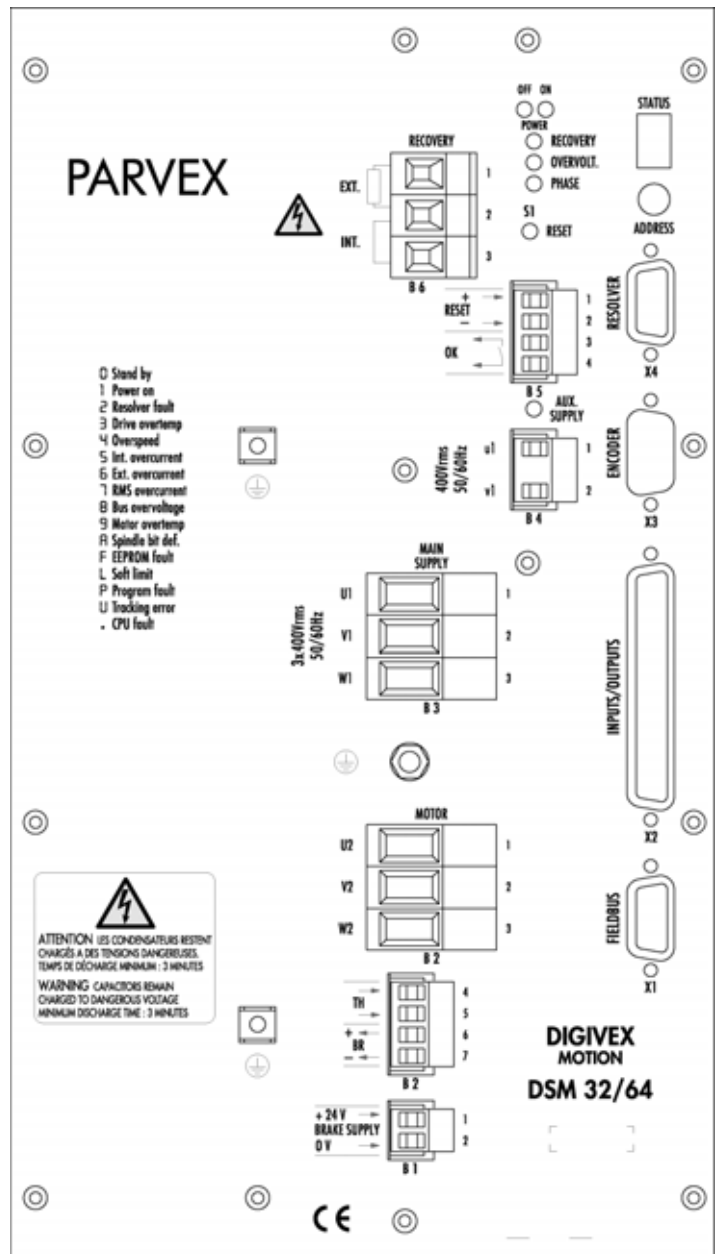
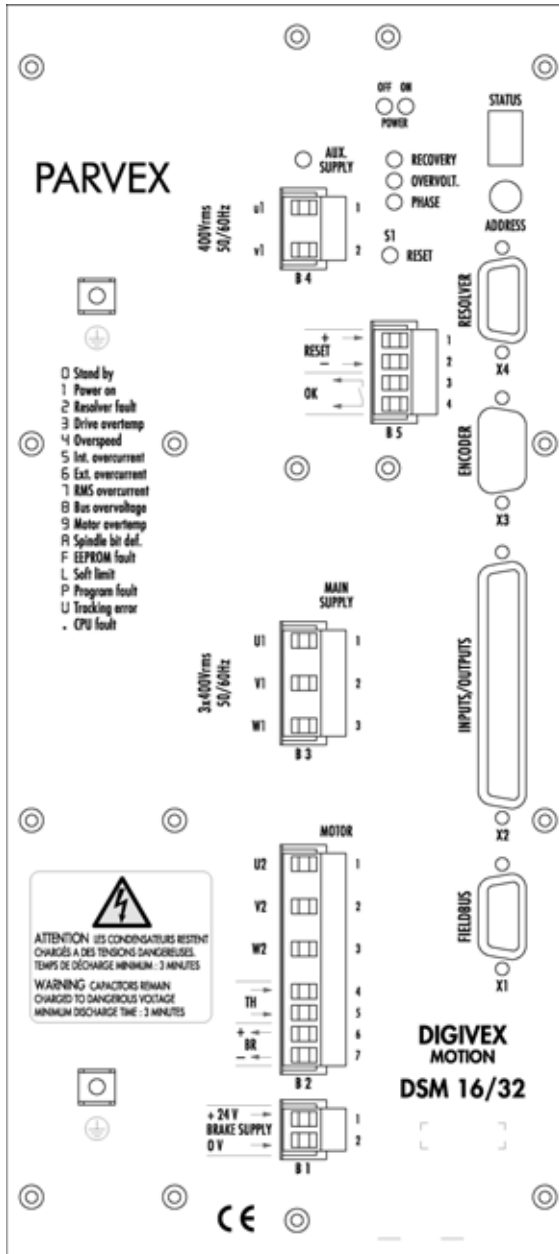

## **5.4 Accessories**

---

### **5.4.1 Input mains filter**

Dimensions as in drawings FELX 305603, 305781, 307020 and 304967 (see following pages).

### **5.4.2 Inductors for long cable lengths with axis motor**

- Between motor and drive. See § 6.3.6 for choice. See FELX 302983 for dimensions (following pages).

### **5.4.3 External braking resistor**

- See drawing FELX 404537 (next page).

# DIGIVEX Single Motion (DSM) Servoamplifier

1	2	3	4
	Position	Text	Identification number
		DIGIVEX	FELX 404537GB P1
		EXTERNAL RESISTOR	

A

B

Standard N°	Power (W)	R (Ω)	L (mm)
RE 91001	2000	27	620
RE 91002	4500	12	1195

Connection in IP55 sealed terminal box with packing gland.  
Weight (kg) : 1 + 9,2L(m)

---

RE 90020

D

Pair of wall consoles  
Weight : 0,9kG

---

**RECOMMENDATION:**  
These resistors must be used horizontally, fixed to the ground or to wall consoles, with nothing liable to impede natural convection.

Service	Drawing	26/07/95	JP	Stamping			
Modifications	A	AM:E98026 - 20/02/98 - VR					

Order of execution

ML

Scale

1

Replacing

Separate nomenclature of Nbe dif.

Separate nomenclature of same Nbr

---

<b>PARVEX</b>	DIGIVEX	SIZE	Family
	EXTERNAL RESISTOR	A4	LEAF N° 1 Nb 1
		FELX 404537GB	

F

This drawing is the exclusiv property of our firm and is strictly confidential. It cannot be transmitted, reproduced or copied without our writing authorization.

# DIGIVEX Single Motion (DSM) Servoamplifier

Position	Text	Identification number	Weight
	MANS FILTER 1Ph OUTLINE DIMENSIONS	FELX 305603GB P1	

U<sub>in</sub> : 110/250Vac 50/60Hz  
 T : 40°C  
 Norm : IEC950

CONNECTION FASTON TAB 6,3x0,8

Pos.	Standard Nr	Current	Max. leakage current (50/60Hz) in mA	Weight
1	FR 01006	6A	3	0,420Kg

  

DIMENSIONS IN mm

  

Service	Drawing	06/02/98	LR	Stamping	Order of execution	ML
A	AME98175 - 09/11/98 - VR				Replacing	
B	AME99061 - 16/04/99 - VR				Separate nomenclature of New dif.	
Modifications						
This drawing is the exclusive property of our firm and is strictly confidential. It cannot be transmitted, reproduced or copied without our written authorisation.						
<b>PARVEX</b>		MANS FILTER 1Ph			Scale	3/2
		OUTLINE DIMENSIONS			Separate nomenclature of same nbr	Family
					SIZE	A3
					LEAF	N° 1 Nbr: 1
					FELX 305603GB	

# DIGIVEX Single Motion (DSM) Servoamplifier

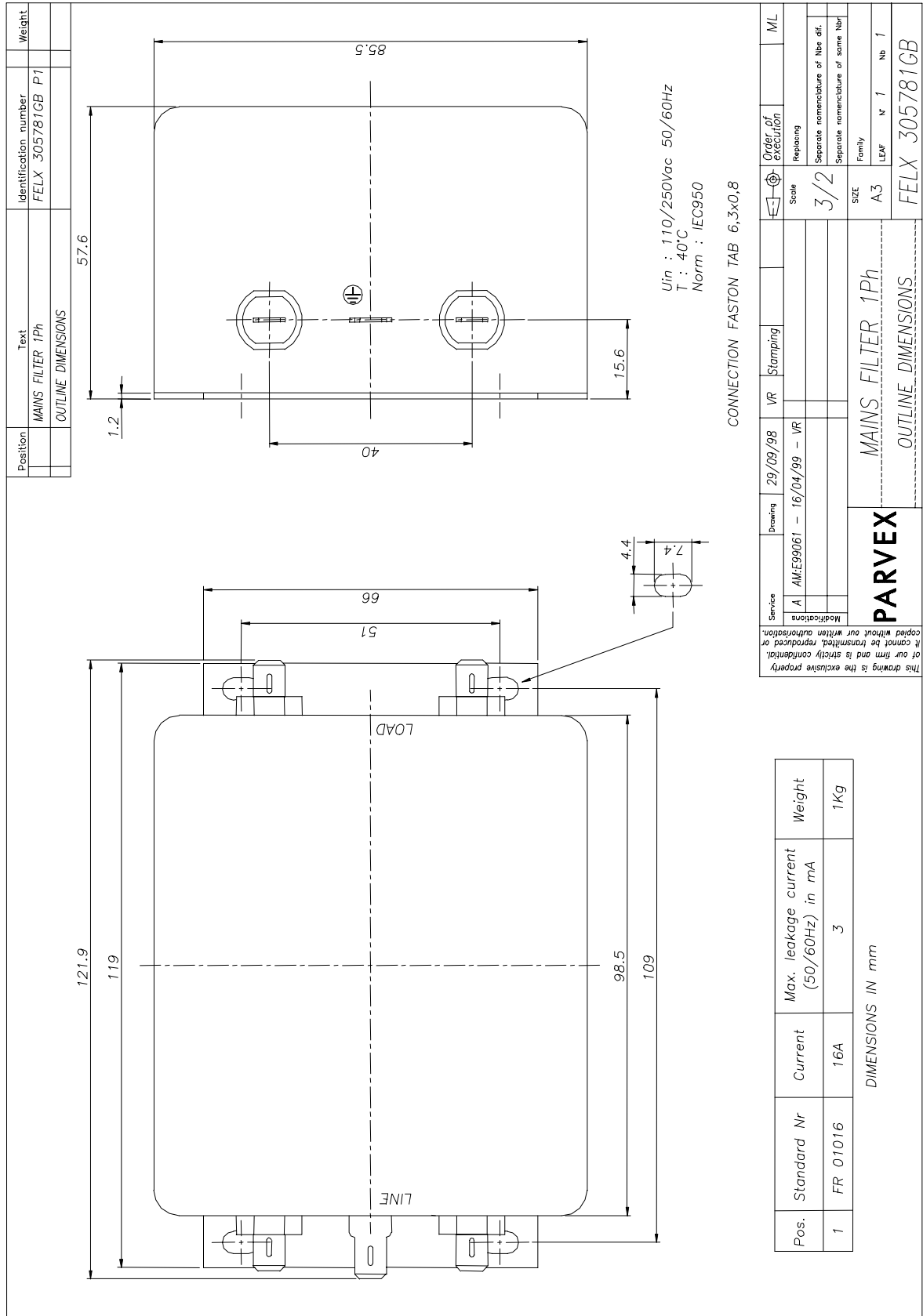

# DIGIVEX Single Motion (DSM) Servoamplifier

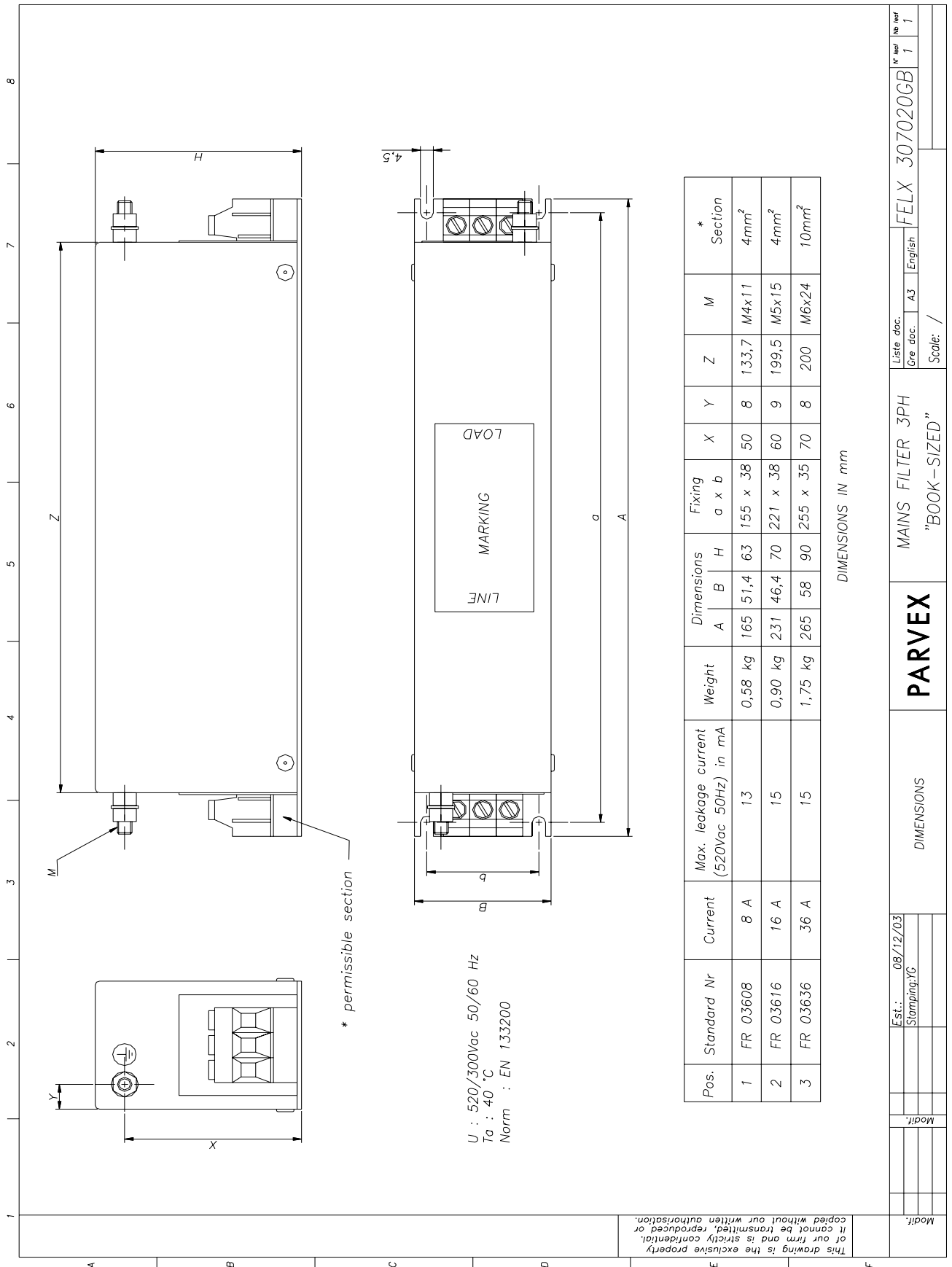

# DIGIVEX Single Motion (DSM) Servoamplifier

Position	Text	Identification number	Weight
	MAINS FILTER 3 ph OUTLINE DIMENSIONS	FELX 304967GB P.	

\* permissible section

U<sub>in</sub> : 440 Vac 50/60Hz  
T<sub>a</sub> : 40°C  
Norm : EN 133200

Pos.	Standard Nr	Current	Dimensions		* Section	Weight
			A	B		
1	FR 03016	16A	241	201	4mm <sup>2</sup>	3Kg
2	FR 03036	36A	251	201	10mm <sup>2</sup>	3Kg
3	FR 03064	64A	308	231	25mm <sup>2</sup>	4Kg

Standard Nr	Max. leakage current (50/60Hz) in mA
FR 03016	30
FR 03036	200
FR 03064	170

Dimensions in mm

Service	drawing	26/06/96	LR	Stamping	ML
A AME97016 - 22/01/97 - LR D AME98066 - 12/05/98 - VR B AME97162 - 20/11/97 - VR E AME98175 - 09/11/98 - VR C AME98035 - 11/03/98 - VR					
Scale Replacing Separate nomenclature of like diff. Separate nomenclature of same type Family SIZE A3 LEAF N° 1 Nib: 1					
<b>PARVEX</b> MAINS FILTER 3 ph OUTLINE DIMENSIONS FELX 304967GB					

This drawing is the exclusive property of our firm and is strictly confidential. It cannot be transmitted, reproduced or copied without our written authorization.

# DIGIVEX Single Motion (DSM) Servoamplifier

	Position	Text	Identification number	Weight
		THREE PHASE CHOKE DIMENSIONS	FELX 302983GB	

No	Standard	Ct nom.	Choke nom.	A	B	C	H	H#	Fixing axb	D	connection area	M	Weight
SF	02025	26A	850uH	150	95	110	/	135	112x80	6	# 6mm <sup>2</sup>	/	4,5kg
SF	02026	65A	340uH	175	95	165	180	/	53x68	6,5	16x16	6,5	9Kg
SF	02027	118A	190uH	290	116	135	210	/	230x100	8	20x20	9	13Kg
SF	02028	17A	1,3mH	160	95	/	115	/	112x71	6	# 6mm <sup>2</sup>	/	4,2Kg
SF	02029	91A	245uH	220	135	160	160	/	166x114	6	20x20	9	15Kg
SF	02030	170A	130uH	235	120	165	240	/	185x100	9	25x28	11	19Kg
SF	02032	7.5A	400uH	132	75	85	/	103	94x55	6x10	# 4mm <sup>2</sup>	/	1,9Kg

The dimensions are in mm

# TERMINAL BLOCK CONNECTION

Service	Drawing	05/02/91	FM	Stamping	ML
A	17/12/92 - AJOUT SF 02032				
B	24/02/97 - MISE A JOUR				
C	AME98035 - 11/03/98 - VR				
Modifications					
Scale /					
Separate nomenclature of Nbr aft.					
Separate nomenclature of some Nbr					
Family					
SIZE A3					
THREE PHASE CHOKE					
DIMENSIONS					
PARVEX					
FELX 302983GB					

This drawing is the exclusive property of our firm and is strictly confidential. It cannot be transmitted, reproduced or copied without our written authorization.



## 6. ELECTRICAL CONNECTIONS

### 6.1 General Wiring Requirements

---

#### 6.1.1 Appliance handling

See the safety instructions given at the beginning of this manual. In particular, wait for all the front panel LEDs to go off completely before doing any work on the servo-amplifier or servomotor.

#### 6.1.2 Electromagnetic compatibility

##### EARTHING

- Comply with all local safety regulations concerning earthing.
- Utilize a metal surface as an earth reference plane (e.g. cabinet wall or assembly grid). This conducting surface is termed the potential reference plate. All the equipment of an electrical drive system is connected up to this potential reference plate by a low impedance (or short distance) link. Ensure the connections provide good electrical conduction by scraping off any surface paint and using fan washers. The drive will then be earthed via a low impedance link between the potential reference plate and the earth screw at the back of the DSM. If this link exceeds 30 cm, a flat braid should be used instead of a conventional lead.

##### CONNECTIONS

- Do not run low-level cables (resolver, inputs/outputs, NC or PC links) alongside what are termed power cables (power supply or motor). Do not run the power supply cable and the motor cables alongside one another otherwise mains filter attenuation will be lost. These cables should be spaced at least 10 cm apart and should never cross, or only at right-angles.
- Except for the resolver signals, all low-level signals will be shielded with the shielding connected at both ends. At the DSM end, the shielding is made continuous by the Sub-D connector mechanism.
- The motor cables are limited to the minimum functional length. The yellow and green motor cable lead must be connected to the box or front panel terminal block with the shortest possible link.
- This usually means shielded motor cable is not required. Chokes may also be inserted into the motor phase leads.

### MAINS FILTERING

The equipment complies with standard EN55011 with a filter on the power input with minimum 60 dB attenuation in the 150 kHz - 30 MHz range.

The mains filter must be mounted as close as possible to the potential reference plate between the mains and the DSM power supply. Use shielded cable (or run the cable in metal trunking). Avoid running cables together, ahead of and after the filter.

Filters sometimes have high leakage currents. In this case, comply with the standard connection diagrams when fitting them.

### OTHER MEASURES

Self-inducting components must be protected against interference: brakes, contactor or relay coils, fans, electro-magnets, etc.

### 6.1.3 DSM Sub-D connectors

In order to ensure the system is free from disturbances, it is essential for the rack to be properly connected to the earth plane of the electrical cabinet and for the covers of the Sub-D connectors to be EMI/RFI shielded (metal with shielding braid connection).

Make sure the Sub-D connectors and their covers are properly connected (lock screws fully tight).

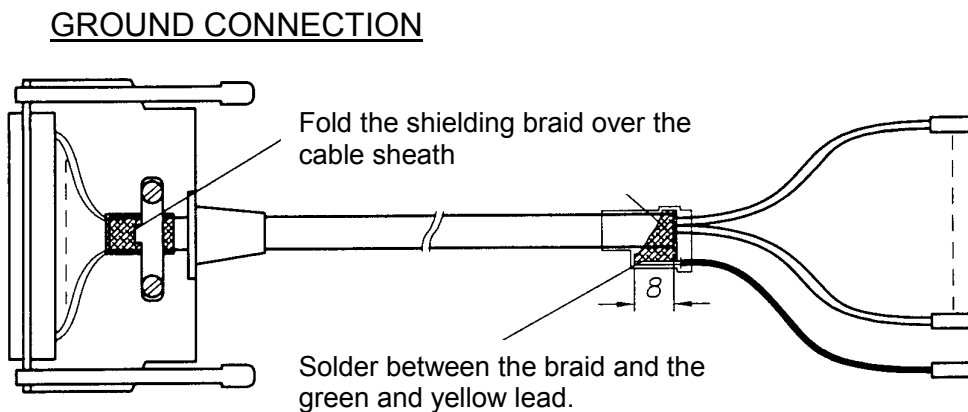

## 6.2 Mains connection and relaying

### 6.2.1 Supply current and fuses

#### 6.2.1.1 Terminal block B3

Description of module terminal blocks: **230V single-phase 2/4, 4/8, 7.5/15A**  
**230V three-phase 15/30A**  
**400V three-phase 2/4, 4/8, 8/16A**  
**400V three-phase 16/32A**

ITEM REF.	TERMINAL	Front Panel Marking	FUNCTION	TERMINAL BLOCK TYPE	TERMINAL CAPACITY
B3/1	U1	MAIN	Mains connection <i>For single-phase mains only B3/1 and B3/2 are to be connected</i>	Unpluggable screw-type	Min 0,2 mm <sup>2</sup> Max 2,5 mm <sup>2</sup> flexible and rigid lead
B3/2	V1				
B3/3	W1	SUPPLY			

Description of module terminal blocks: **230V three-phase 30/60A**  
**230V three-phase 60/100A**  
**400V three-phase 32/64A**

ITEM REF.	TERMINAL	Front Panel Marking	FUNCTION	TERMINAL BLOCK TYPE	TERMINAL CAPACITY
B3/1	U1	MAIN SUPPLY	Mains connection <i>For single-phase mains only B3/1 and B3/2 are to be connected</i>	Not unpluggable screw-type	<u>30/60 and 32/64</u> Min 0,2 mm <sup>2</sup> Max flexible lead 6 mm <sup>2</sup>
B3/2	V1				
B3/3	W1	Earth			

#### 6.2.1.2 one single drive

Applicable to components ahead of the DSM (fuses, cables, contactors, etc.), dimensions vary with appliance rating:

DIGIVEX Rating	INPUT POWER FOR 230V SINGLE-PHASE MAINS kW	LINE CURRENT for mains Urms = 230 V SINGLE-PHASE A rms	FUSE RATING Type gG *	MAINS FILTER
2/4	0.5	2	2	FR01006
4/8	1	4	4	
7.5/15	2	8	8	FR01016

## DIGIVEX Single Motion (DSM) Servoamplifier

DIGIVEX Rating	INPUT POWER FOR 230V THREE-PHASE MAINS kW	LINE CURRENT for mains Urms = 230 V THREE-PHASE A rms	FUSE RATING Type gG *	MAINS FILTER " Book-Sized "	MAINS FILTER
4/8	1	2.5	4	FR03608	FR03016
7.5/15	2	5	6		
15/30	4	10	10		
30/60	8	20	20	FR 03636	FR03036
60/100	16	40	40		

DIGIVEX Rating	INPUT POWER FOR 400V THREE-PHASE MAINS kW	LINE CURRENT for mains Urms = 400 V THREE-PHASE A rms	FUSE RATING Type gG *	MAINS FILTER " Book-Sized "	MAINS FILTER
2/4	1	1.3	2	FR03616	FR03016
4/8	2	2.5	4		
8/16	3,5	5	6		
16/32	7	10	10	FR03636	FR03036
32/64	14	20	20		

\* Fuses may be replaced by circuit breakers of equivalent ratings.

### 6.2.1.3 several drives in parallel

The cable cross-section and contactor rating must be selected accordingly.

One filter may be used for several drives. In this case, the leading fuses and the filter should be rated as follows. However, the lines to each drive should be protected as in the table below and in keeping with the wiring diagram.

MAINS INPUT	FUSE RATING Type gG	MAINS FILTER " Book-Sized	MAINS FILTER
0 – 5 kW	10	FR03608	-
0 – 10 kW	16	FR03616	FR03016
10 – 22 kW	32	FR03636	FR03036
22 – 45 kW	64	-	FR03064

### 6.2.2 Standard Connection Diagram

See the drawings on the following pages

- FELX 305896
- FELX 305897
- FELX 305899
- FELX 305901
- FELX 305998
- FELX 305900

# DIGIVEX Single Motion (DSM) Servoamplifier

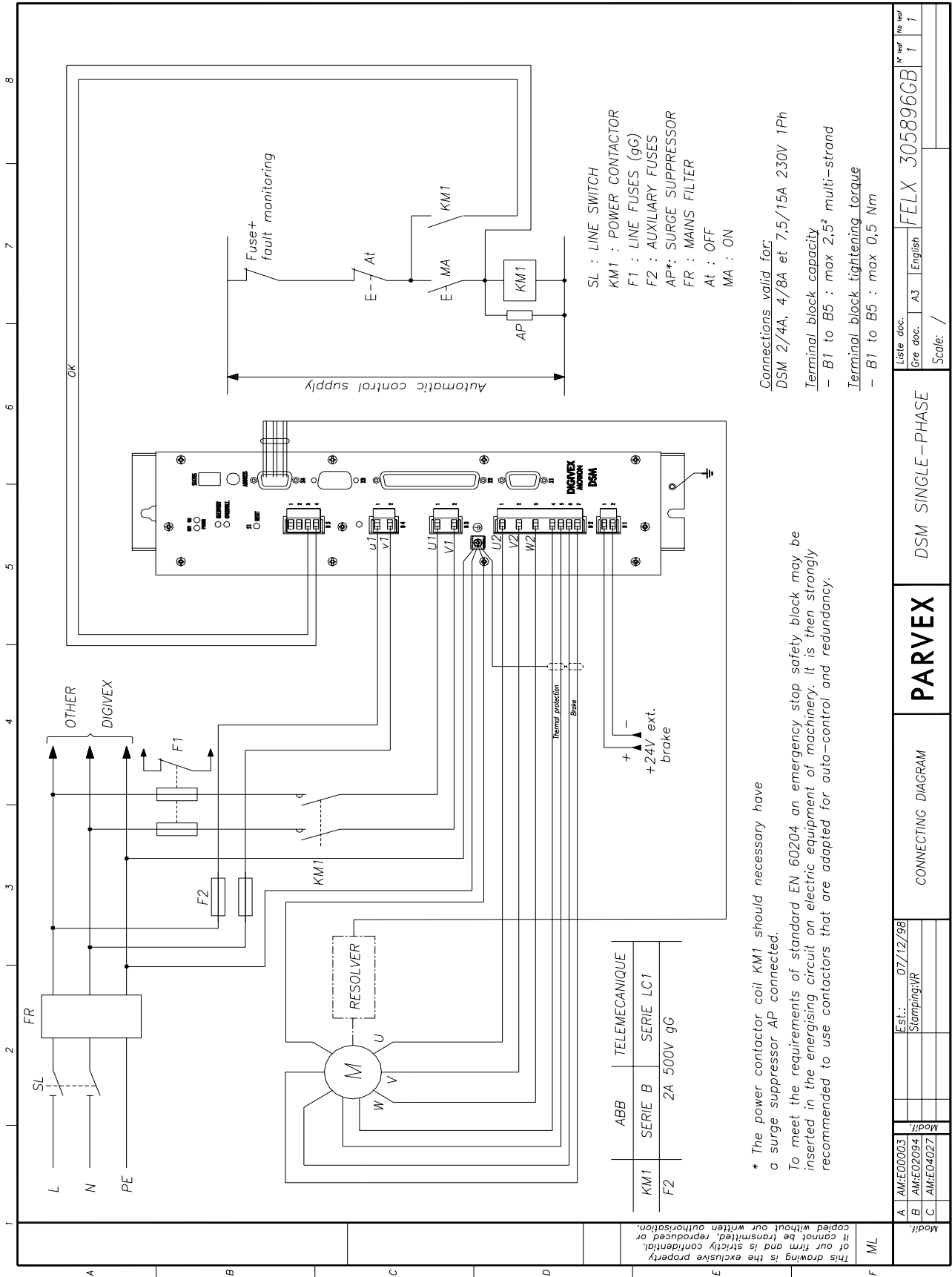

Modif.:		Est.: 07/12/98		Liste doc.:		No part	
A	AM:EO0003			A3	English	FELX 305896GB	
B	AM:EO2094	Stamping:VR					
C	AM:EO4027						
Modif.:				Scale: /			
CONNECTING DIAGRAM				DSM SINGLE-PHASE			

# DIGIVEX Single Motion (DSM) Servoamplifier

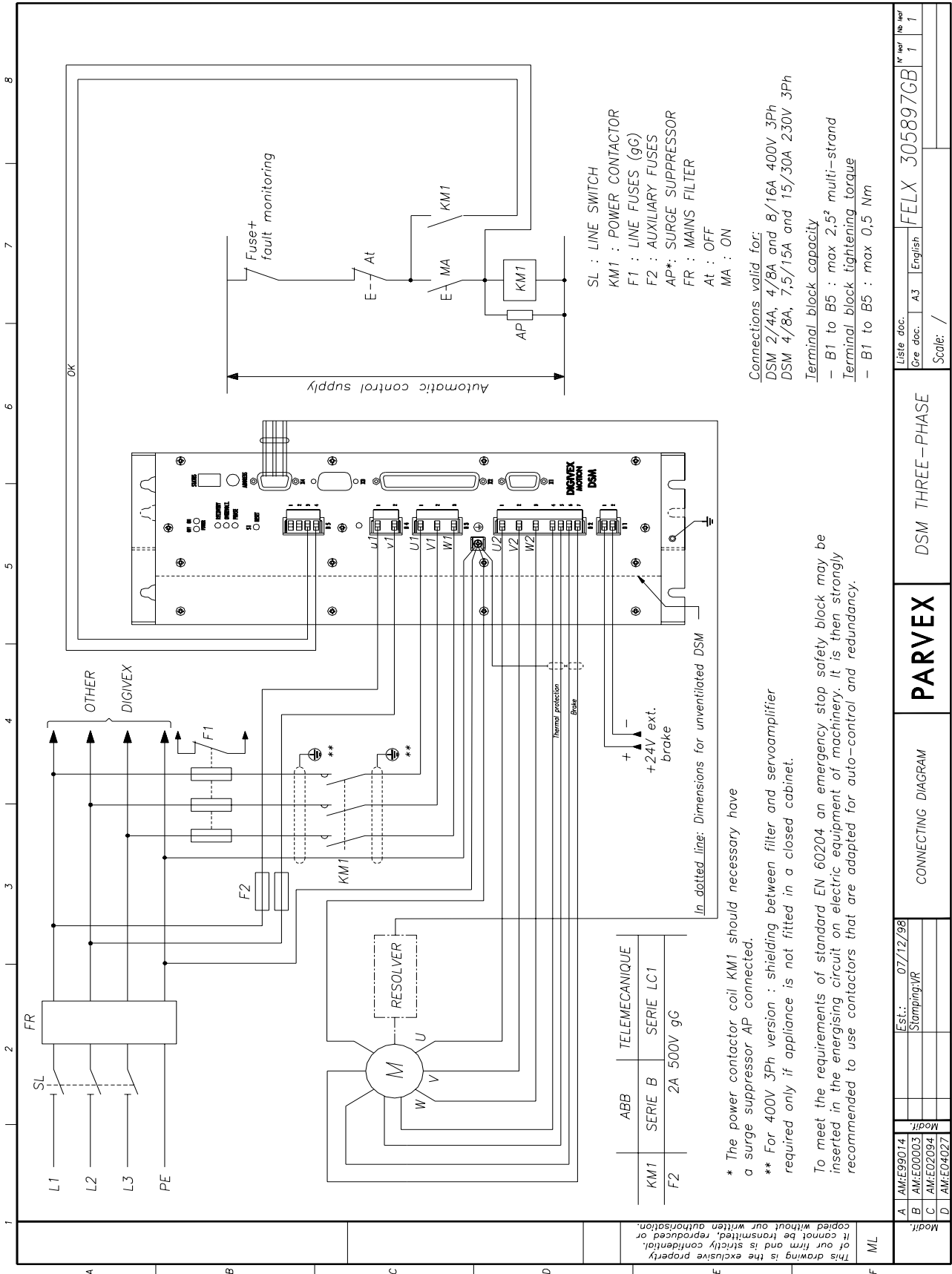

Liste doc.	Gre doc.	A3	English	FELX 305897GB	N° rev	1
Scale: /						

DSM THREE-PHASE

**PARVEX**

CONNECTING DIAGRAM

A	AM:E99014	Est.:	07/12/98
B	AM:E00003	Stamping	VR
C	AM:E02094		
D	AM:E04027		

This drawing is the exclusive property of our firm and is strictly confidential. It cannot be transmitted, reproduced or copied without our written authorisation.

# DIGIVEX Single Motion (DSM) Servoamplifier

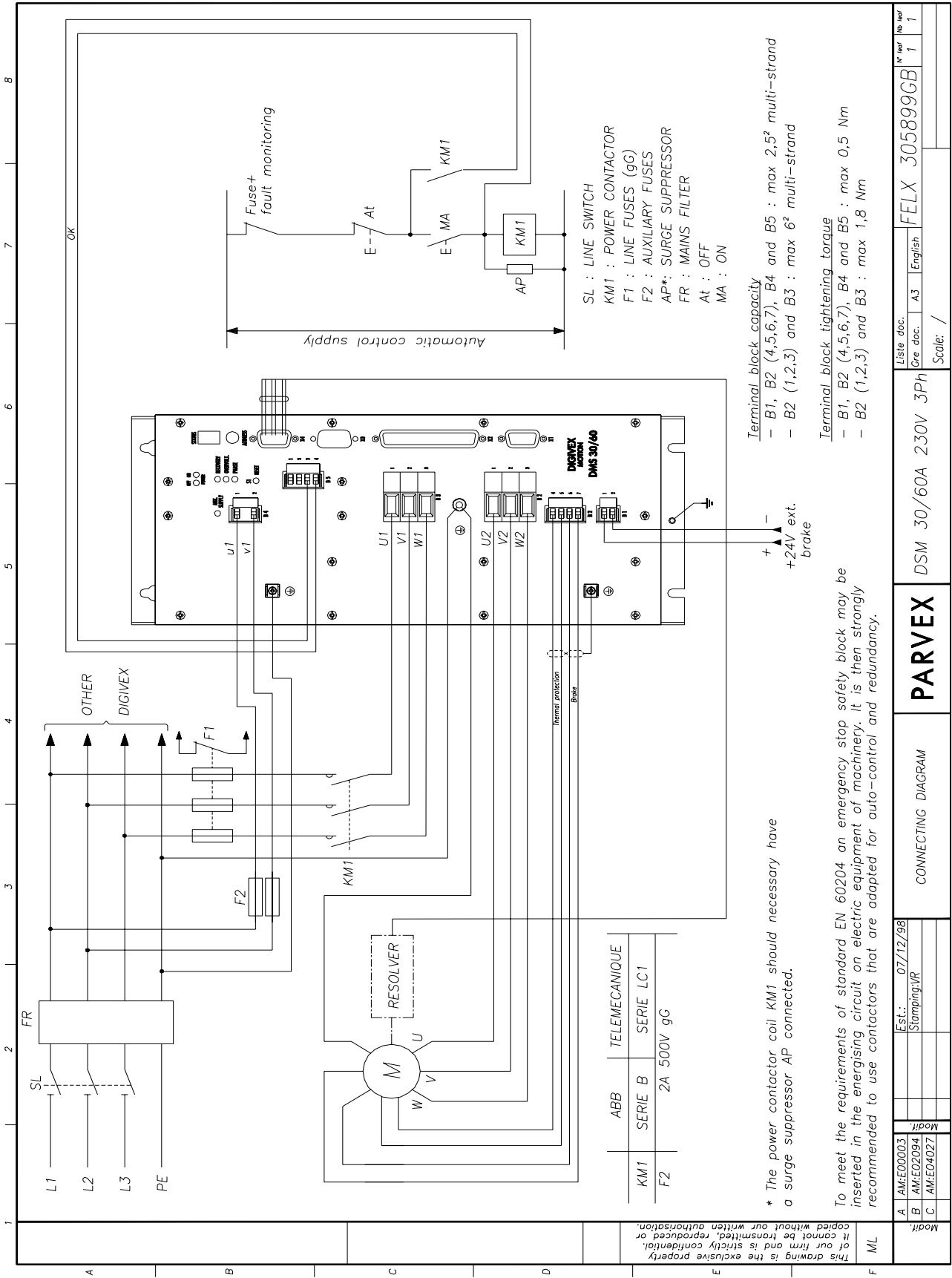

A	AM:E00003	Est.:	07/12/98						
B	AM:E02094	Stamping:VR							
C	AM:E04027								
Modif:									
CONNECTING DIAGRAM				PARVEX		DSM 30/60A 230V 3Ph		FELX 305899GB	
Liste doc.:		A3		English					
Gre doc.:									
Scale:		/							

This drawing is the exclusive property of our firm and is strictly confidential. It cannot be transmitted, reproduced or copied without our written authorisation.

# DIGIVEX Single Motion (DSM) Servoamplifier

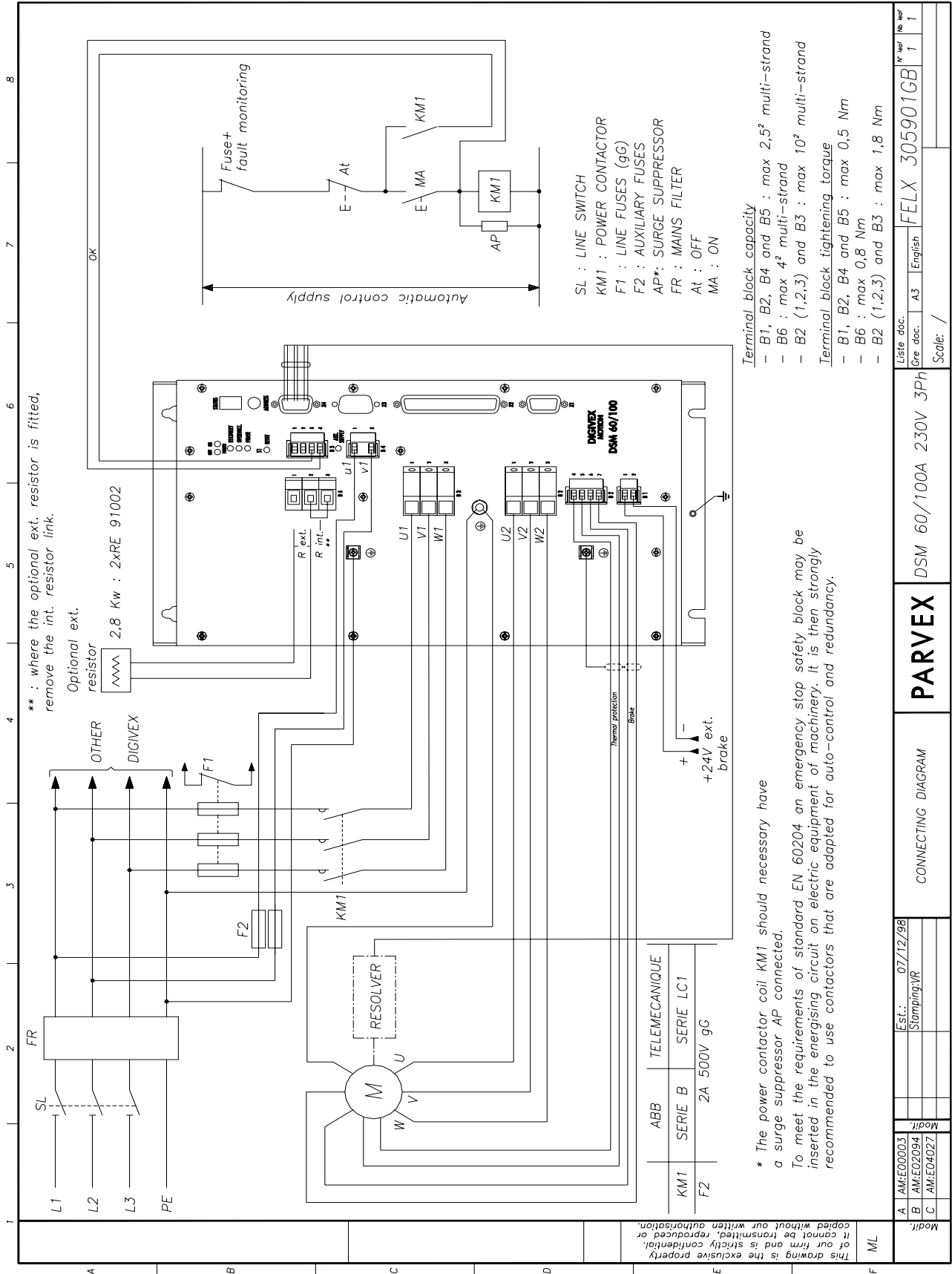



# DIGIVEX Single Motion (DSM) Servoamplifier

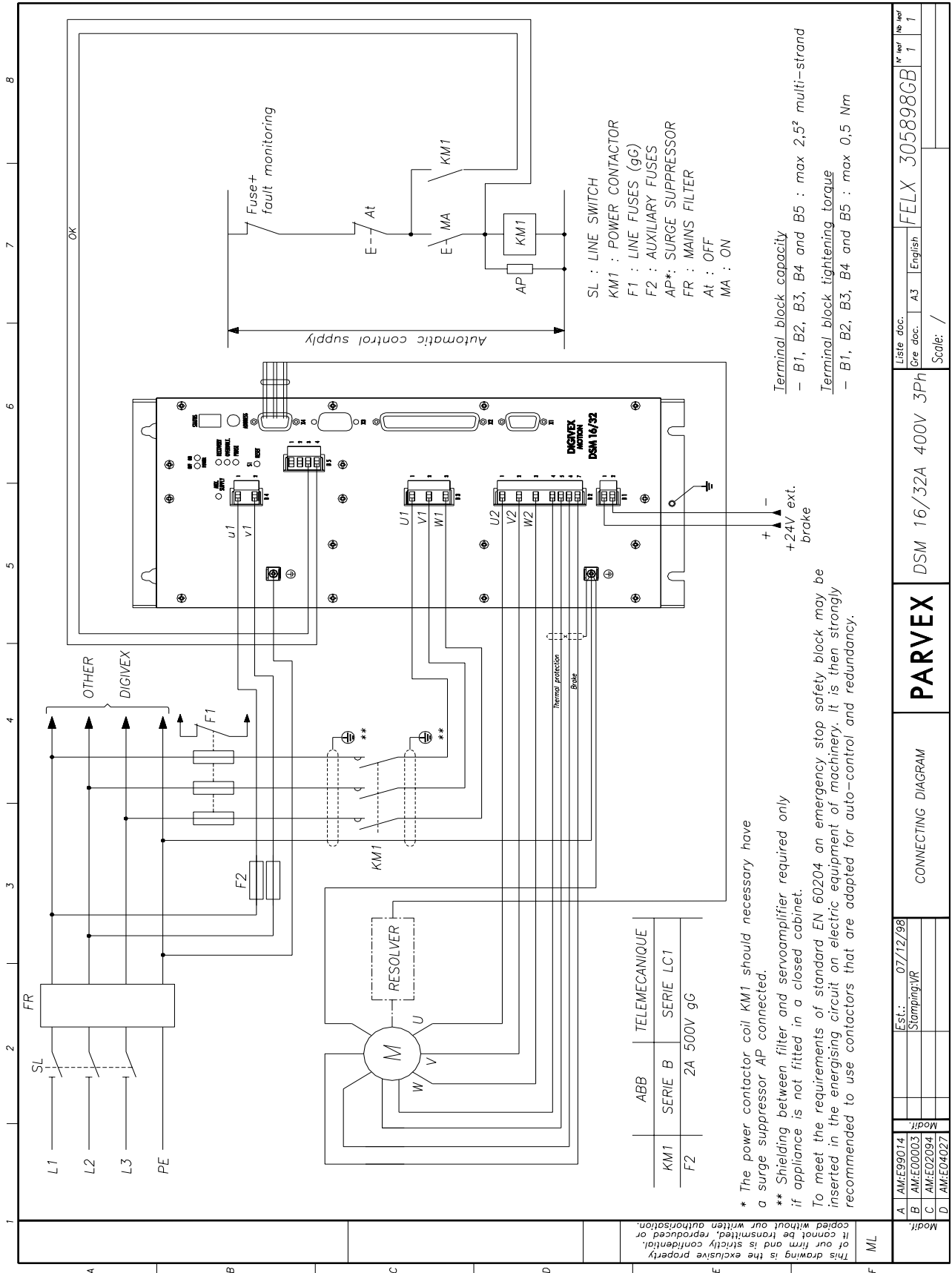

This drawing is the exclusive property of our firm and is strictly confidential. It cannot be transmitted, reproduced or copied without our written authorisation.		Modif. A AM:E99014		Est.: 07/12/98		Liste doc. FELX 305898GB		N° rev. No rev	
		B AM:E00003		Stamping,VR		Gre doc. A3 English		1 1	
		C AM:E02094							
		D AM:E04027							
						DSM 16/32A 400V 3Ph			
						<b>PARVEX</b>			
				CONNECTING DIAGRAM					

# DIGIVEX Single Motion (DSM) Servoamplifier

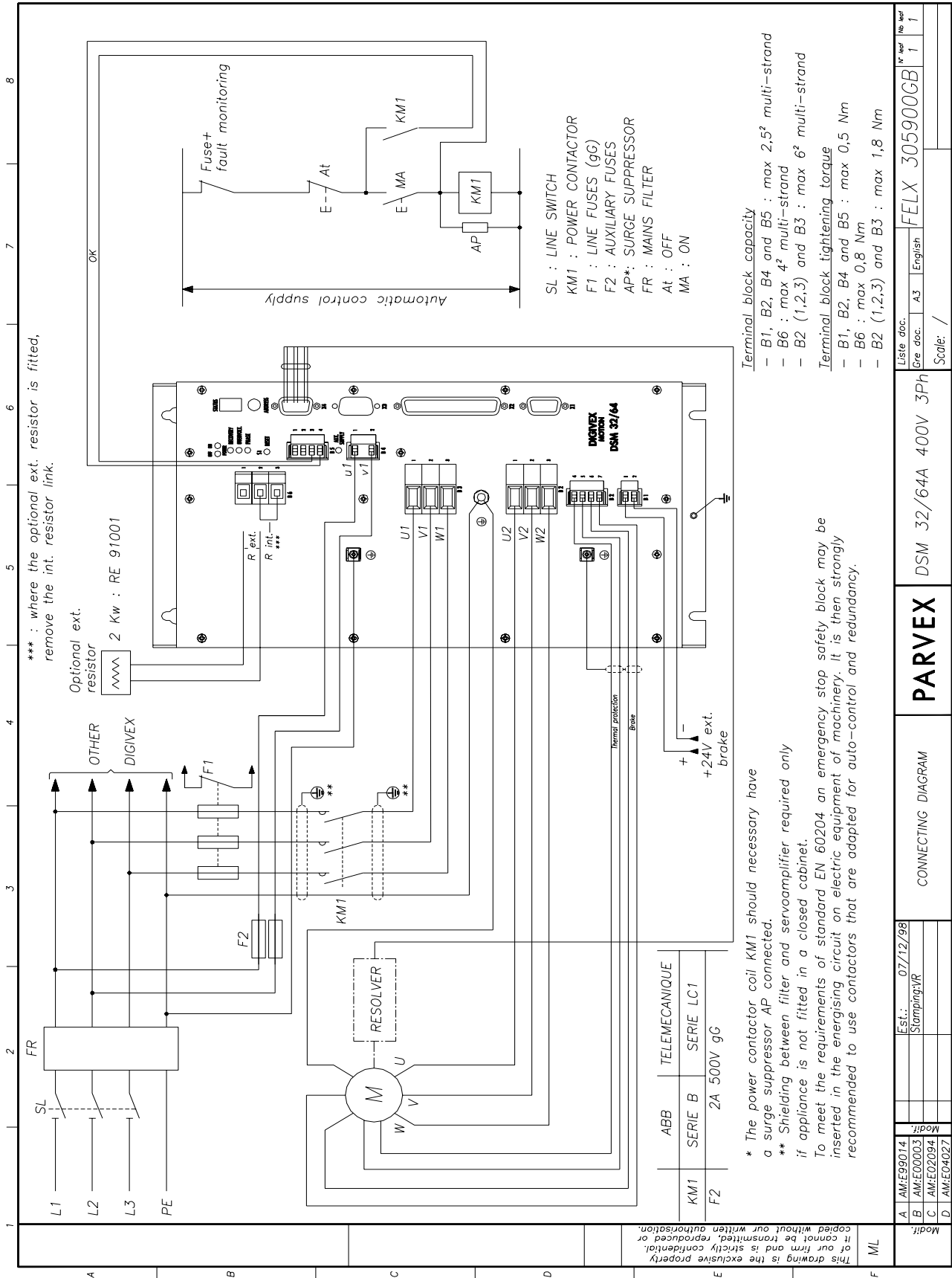

### 6.2.3 Surge Suppressor

- KM1: Power Contactor
- AP: Surge Suppressor

The power contactor coil KM1 should **necessary** have a surge suppressor AP connected in order not to destroy prematurely the internal relay contact of the drive. This module should be use whether the power contactor supply is AC or DC.

The relay manufacturers (Telemecanique: LC1 series, ABB: B series,...) provide surge suppressors fitted relays wether the power contactor supply is AC or DC for various voltages (RC module, Diode+Zener Diode, Varistor,...).

## 6.2.4 Earth connection (front panel Faston tab)



Chassis earth:

For compliance with the standards in force, the lead cross-section must normally be identical to that of the mains connection and at least 16mm<sup>2</sup>.

## 6.2.5 Auxiliary power supply

### 6.2.5.1 Description

The power supplies required for regulation (+/- 15 V, 5 V, 24 V) are drawn from an intermediate dc voltage which may be obtained:

- either from a single-phase supply from the mains, drawn between two phases ahead of the main contactor (terminal block B4 input).
- or from a separate single-phase (230 V or 400 V) supply connected to terminal block B4. In this case, the supply must be isolated from the mains by a transformer (secondary 230 V or 400 V +/- 10% 100VA).
- or internally from the power section supply, via diodes (B4 not connected). With this option (not recommended), failure of the power section means the low level supply is lost and in particular the pulses generated by the "encoder emulation" option.

### 6.2.5.2 Terminal block B4

**Description of module terminal blocks:** 230V single-phase 2/4, 4/8, 7.5/15A  
 230V three-phase 15/30A  
 400V three-phase 2/4, 4/8, 8/16A  
 400V three-phase 16/32A  
 230V three-phase 30/60A  
 230V three-phase 60/100A  
 400V three-phase 32/64A

ITEM REF.	TERMINAL	Front Panel Marking	FUNCTION	TERMINAL BLOCK TYPE	TERMINAL CAPACITY
B4/1 B4/2	v1 u1	AUX. SUPPLY	Low-level supply	Unpluggable screw-type	Min 0,2 mm <sup>2</sup> Max 2,5 mm <sup>2</sup> flexible and rigid lead

### 6.2.6 Automatic control Input / Output connection

#### 6.2.6.1 RESET and Contactor Control

- |        |                              |
|--------|------------------------------|
| - B5/1 | Reset + (24V DC logic input) |
| - B5/2 | Reset – (0V)                 |

A 24 V leading edge applied to B5/1 compared with B5/2 reinitializes the system after power supply or drive failure.

Notice that the system can also be reset by the "reset" button on the front panel or by switching the power supply off completely (power and auxiliaries).

This control has no effect during normal operation. The system must be "reset" after any active fault.

See the PME-DIGIVEX Motion setting and adjustment manual for further details.

- |                 |                                                     |
|-----------------|-----------------------------------------------------|
| - B5/3 – B5/4 : | <b>Contact OK</b>                                   |
|                 | <b>Cut-out power : max voltage 250 Vac, max 1A.</b> |

This contact is closed if:

- the auxiliary supply AUX is present.
- the power supply is present.
- the drive indicate no faults.

This contact authorizes the main contactor to self-hold

**ATTENTION:** Opening the OK contact must cause the main contactor to open with a maximum delay of 100 ms.

#### **Main contactor control**

Opening the OK relay causes the main contactor to open. The OK relay opens under the following circumstances:

- No phase.
- Recovery fault.
- Maximum power bus voltage.
- Minimum power bus voltage.
- Positioner fault.
- Auxiliary supply fault.
- Maximum mains voltage.

### 6.2.6.2 Terminal block B5

Description of module terminal blocks: 230V single-phase 2/4, 4/8, 7.5/15A  
 230V three-phase 15/30A  
 400V three-phase 2/4, 4/8, 8/16A  
 400V three-phase 16/32A  
 230V three-phase 30/60A  
 230V three-phase 60/100A  
 400V three-phase 32/64A

ITEM REF.	TERMINAL	Front Panel Marking	FUNCTION	TERMINAL BLOCK TYPE	TERMINAL CAPACITY
B5/1 B5/2	+ -	RESET	Logic input RESET	Unpluggable screw-type	Min 0,2 mm <sup>2</sup> Max 2,5 mm <sup>2</sup> flexible and rigid lead
B5/3 B5/4		OK	OK contact (regulation and power OK)		

## 6.3 Motor end connection

### 6.3.1 Terminal block B2

Description of module terminal blocks: 230V single-phase 2/4, 4/8, 7.5/15A  
 230V three-phase 15/30A  
 400V three-phase 2/4, 4/8, 8/16A  
 400V three-phase 16/32A

ITEM REF.	TERMINAL	Front Panel Marking	FUNCTION	TERMINAL BLOCK TYPE	TERMINAL CAPACITY
B2/1 B2/2 B2/3	U2 V2 W2	MOTOR	Motor connection	screw-type	Min 0,2 mm <sup>2</sup> Max 2,5 mm <sup>2</sup> flexible and rigid lead
B2/4 B2/5	TH TH	TH	Motor thermal protection	Unpluggable	
B2/6 B2/7	+ -	BR	Motor brake		

Description of module terminal blocks: 230V three-phase 30/60A  
 230V three-phase 60/100A  
 400V three-phase 32/64A

ITEM REF.	TERMINAL	Front Panel Marking	FUNCTION	TERMINAL BLOCK TYPE	TERMINAL CAPACITY
B2/1 B2/2 B2/3	U2 V2 W2	MOTOR	Motor connection	Not unpluggable screw-type	<u>30/60 and 32/64</u> Min 0,2 mm <sup>2</sup> Max flexible lead 6 mm <sup>2</sup> <u>60/100</u> Min 0,5 mm <sup>2</sup> Max flexible lead 10 mm <sup>2</sup>
B2/4 B2/5 B2/6 B2/7	TH TH + -	TH BR	Motor thermal protection Motor brake	Unpluggable screw-type	Min 0,2 mm <sup>2</sup> Max 2,5 mm <sup>2</sup> flexible and rigid lead

### 6.3.2 Motor Power connection

There are two possibilities for connection:

- Terminal block + resolver connector.
- Power connector + resolver connector.

### 6.3.3 Terminal block connection

For the terminal block, the clamping nuts and washer come in a bag  
Take care when fitting the lugs not to loosen the connecting leads between the motor and the terminal block.

The power connection lugs are to be inserted between the striated washer and the flat washer.

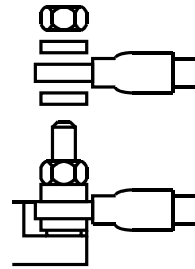

Digpl3.D

**Motor direction of rotation:** by wiring as recommended, a positive set point applied to the drive entails clockwise rotation (viewed from the power shaft end).

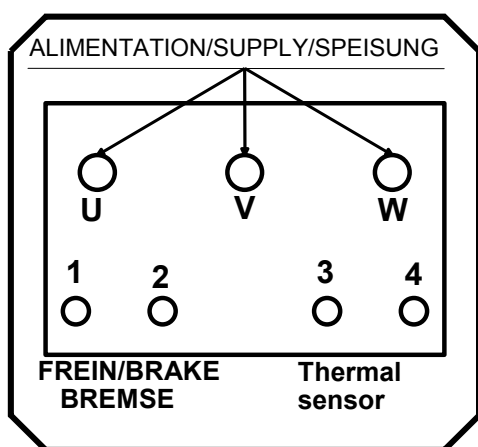

U Phase U

V Phase V

W Phase W

1 Optional brake +24 V

cable  $\geq 1\text{mm}^2$

2 Optional brake 0 V

3 Thermal sensor

cable  $\geq 1\text{mm}^2$

4 Thermal sensor

### 6.3.4 Power connector connection

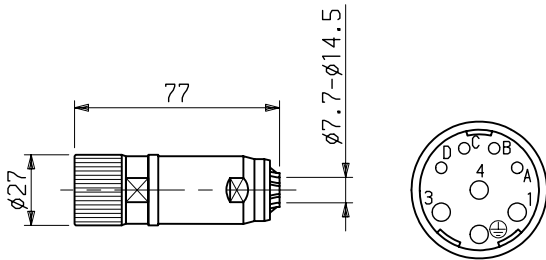

PLUG 220065R1610/1611

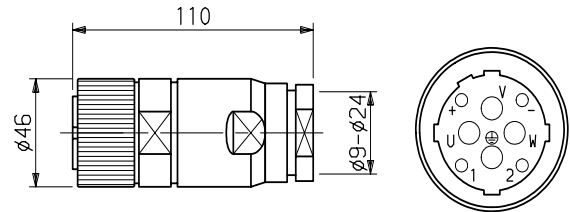

PLUG 220065R3610/3611

#### CABLE CROSS-SECTION FOR PLUGS

PLUG 220065R1610 : power & earth: 0.14 - 1.5 mm<sup>2</sup>. Brake & thermal: 0.14 - 1 mm<sup>2</sup>  
 PLUG 220065R1611 : power & earth: 0.75 - 2.5 mm<sup>2</sup>. Brake & thermal: 0.14 - 1 mm<sup>2</sup>  
 PLUG 220065R3611 : power & earth: 1.5 - 4 mm<sup>2</sup>. Brake & thermal: 1 - 2.5 mm<sup>2</sup>  
 PLUG 220065R3610 : power & earth: 6 - 16 mm<sup>2</sup>. Brake & thermal: 1 - 2.5 mm<sup>2</sup>

FUNCTION	PLUG PINS		CABLE COLOR
	220065R1610/R1611	220065R3610/R3611	
BRAKE +	A	+	Green/Red
BRAKE -	B	-	Green/Blue
THERMAL PROTECTION	C	1	Orange
THERMAL PROTECTION	D	2	Yellow
EARTH	2	⊕	Green/Yellow
U <sub>2</sub>	1	U	Black
V <sub>2</sub>	4	V	White
W <sub>2</sub>	3	W	Red
Shielding to be connected to the earth at the servoamplifier end ⊕			Green/Orange



### **6.3.5 Power cable definition**

The motor / drive power connection cables will have as a minimum:

- three isolated conductors connected to phases U2, V2, W2. Cross-sections as in the table on the next page. The presence of chokes internal to the DIGIVEX means there is no need for shielding of the three power conductors.
- 1 earth conductor (green and yellow).
- twisted and shielded pair for connection of the motor thermal protection. Cross-section in the order of 1mm<sup>2</sup>.
- twisted and shielded pair for connection of the holding brake (if present). Cross-section in the order of 1mm<sup>2</sup>.
- 1 "shielding continuity" conductor (green/orange) to be connected to the servoamplifier earth 

#### **Power cable cross-section**

The cable cross-sections given in the table below take account of:

- The rated drive current.
- The motor / drive distance, service voltage loss = RI.
- The ambient temperature, cable Joule losses = RI<sup>2</sup>.
- the standardized increase in cable sections.

The cable section to be used is given in the table below

Distance →	0m	50m	100m
DIGIVEX Rating	Cable cross-section in mm <sup>2</sup>		
2/4 and 4/8	0.5		1
7.5/15 and 8/16	1		2.5
16/32 and 15/30	2.5		6*
32/64 and 30/60	6		10*
60/100	10		16*

\* cross-section incompatible with power terminal blocks see § 6.3.1 Provide an intermediate terminal block nearby.

**Power connection**

List of power cables, power connectors, and equipped cables for NX, H or L series motors

<b>MOTOR</b>	<b>Cable cross-section (mm<sup>2</sup>)</b>	<b>Power Cable</b>	<b>Power Plug (1)</b>	<b>Equipped Cable</b>
<b>NX1-NX2</b> Molex connector	1	6537P0023	220004R1000	220154R12xx
<b>NX1-NX2</b> Heavy-duty connector	1	6537P0023	220065R1610	220154R32xx
<b>NX3-NX4-NX6-NX8</b> <b>HX2-HX3-HX4</b> <b>LX2-LX3-LX4</b> <b>HS-HD-HX6/HS8</b> <b>LS-LD-LX6/LS8</b>	0,5	6537P0019	220065R1610	220049R49xx
	1	6537P0009	220065R1610	220049R42xx
	2,5	6537P0010	220065R1611	220049R43xx
<b>HD-HX-HV8</b> <b>LD-LX-LV8</b> <b>HS9</b> <b>LS9</b> <b>HD-HV9</b> <b>LD-LV9</b> <b>HXA-HVA</b> <b>AllHW et LV</b> <b>HD-HV1000</b> <b>LD-LV1000</b>	2,5	6537P0010	220065R3611	220049R48xx
	6	6537P0011	220065R3610	220049R45xx
	10	6537P0012	220065R3610	220049R46xx
	16	6537P0013	220065R3610	220049R47xx
	25	6537P0014	-	-

Length 5 m / 10 m / 15 m / 25 m / 50 m. Add the length in metres to the cable product number.

(1) Option for L and H motors

For more détails, see the "user and commissioning" manuals of motors :

PVD3407 : LX-LS-LD-HD  
 PVD3490 : HX-HS-HD-HV  
 PVD3535 : NX

### 6.3.6 Guidelines for the use of long cables

The inductors and, where necessary, the resistors are to be fitted between the DIGIVEX Multi Drive (as close as possible to the drive) and the motor when used with long cable lengths.

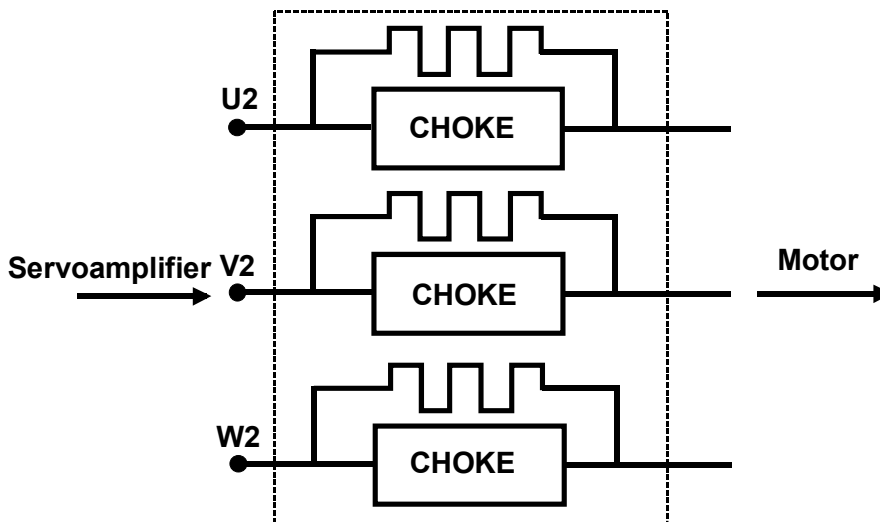

#### References of inductors

	Cable length (L)	Normal	L ≤ 20 m	20 < L < 30 m	30 ≤ L < 70 m	70 ≤ L < 100 m
		Shielded	L ≤ 15 m	15 < L < 20 m	20 ≤ L < 50 m	50 ≤ L < 70 m
DIGIVEX Single Motion	2/4 – 4/8	-	-	DSF02 Fréq* : 8kHz	DSF02 Freq* : 4kHz	Not recommended
	7,5/15 – 8/16	-	-	-	DSF02 Freq* : 4kHz	SF02032 + resistor Freq* : 4kHz
	15/30 to 32/64	-	-	-	SF02025+ resistor Freq* : 4kHz	SF02025+ resistor Freq* : 4kHz
	60/100	-	-	-	SF02026+ resistor Freq* : 8kHz	SF02026+ resistor Freq* : 4kHz

Freq\*: Power bridge cutting frequency

Default frequency: 8kHz (factory setting for the drive; please refer to the PVD 3516: PME-DIGIVEX Motion Adjustment Manual, Hardware section, for the frequency selection)

Long cable lengths usually involve frequencies of 4kHz in line with the table below.

- DSF02: three inductances of 50 mH damped by resistors to rise on rail DIN
- For lengths superior to 100 m, consult us.
- Damping resistor to be used with SF02025, SF02026 and SF02032: RE 40008 470 Ω 25 W

The use of self dampers for shorter distances can be envisaged to reduce parasite reception, caused by capacitive coupling with power cables.

# DIGIVEX Single Motion (DSM) Servoamplifier

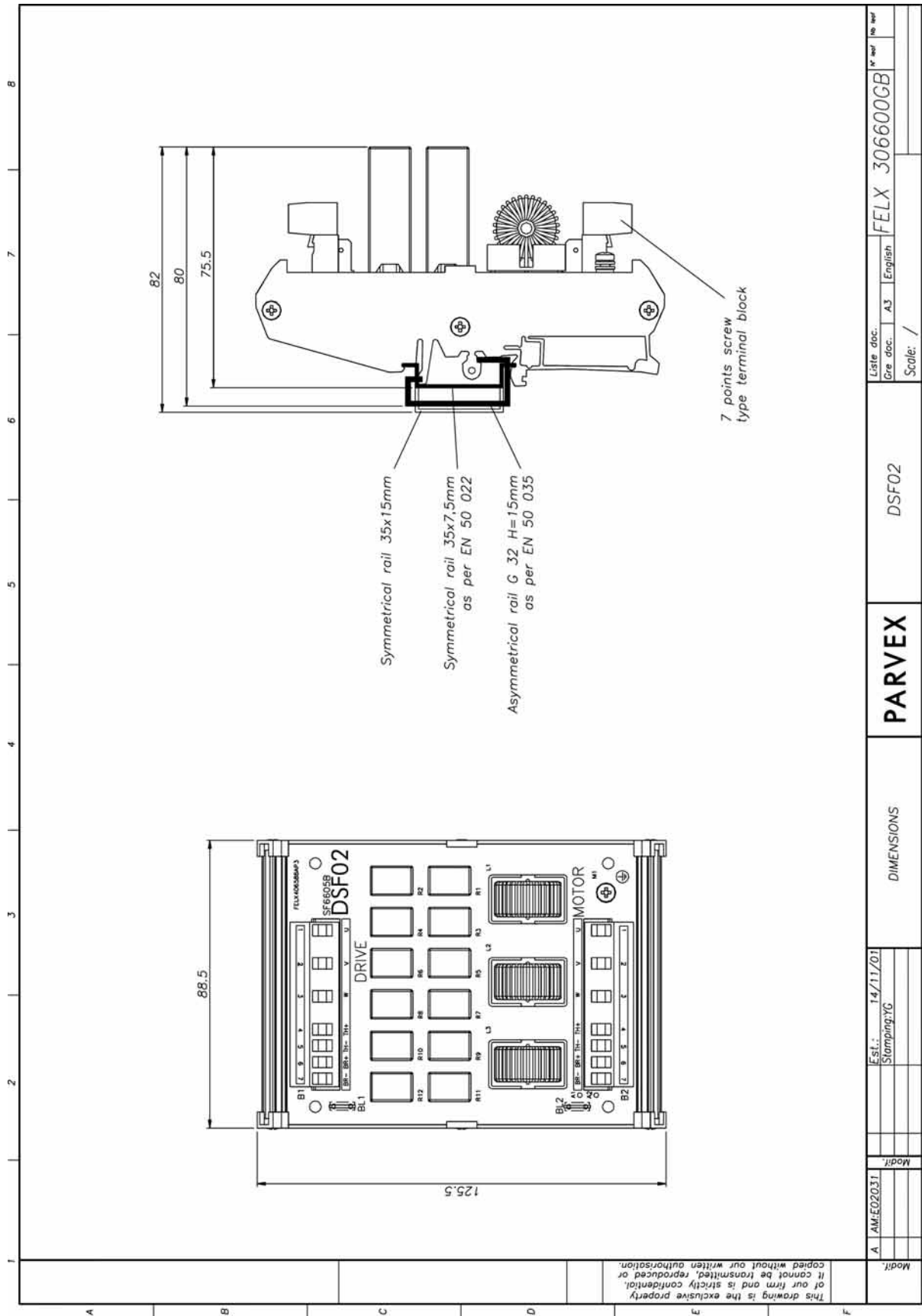

Modif:	A	AM:EQ2031	Modif:	
Est.:	14/11/01	Stamping/YG		
DIMENSIONS		PARVEX		
DSF02		FELX 306600GB		
Liste doc.	Gre doc.	A3	English	No ref
Scale: /				

This drawing is the exclusive property of our firm and is strictly confidential. It cannot be transmitted, reproduced or copied without our written authorisation.

# DIGIVEX Single Motion (DSM) Servoamplifier

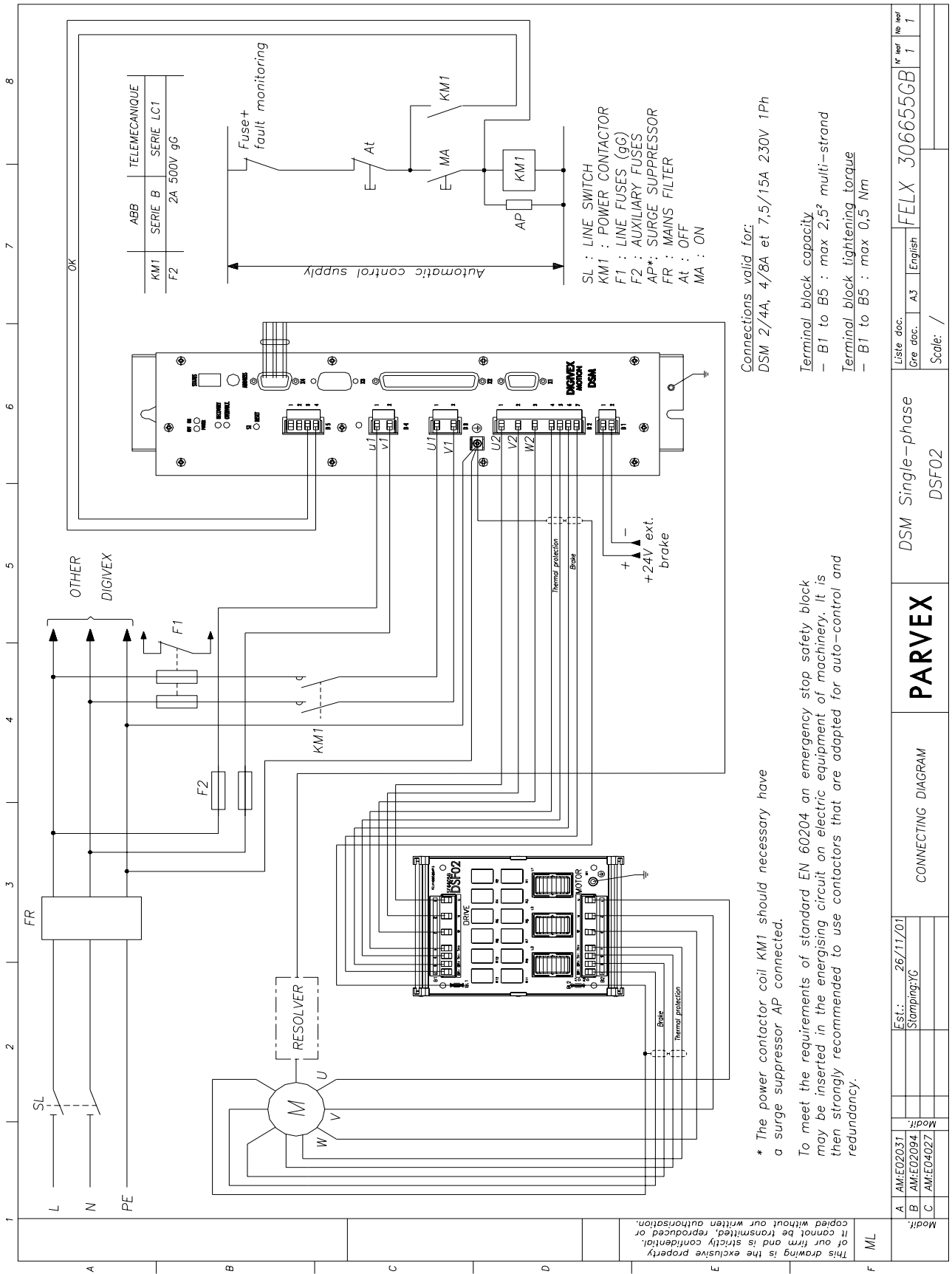

# DIGIVEX Single Motion (DSM) Servoamplifier

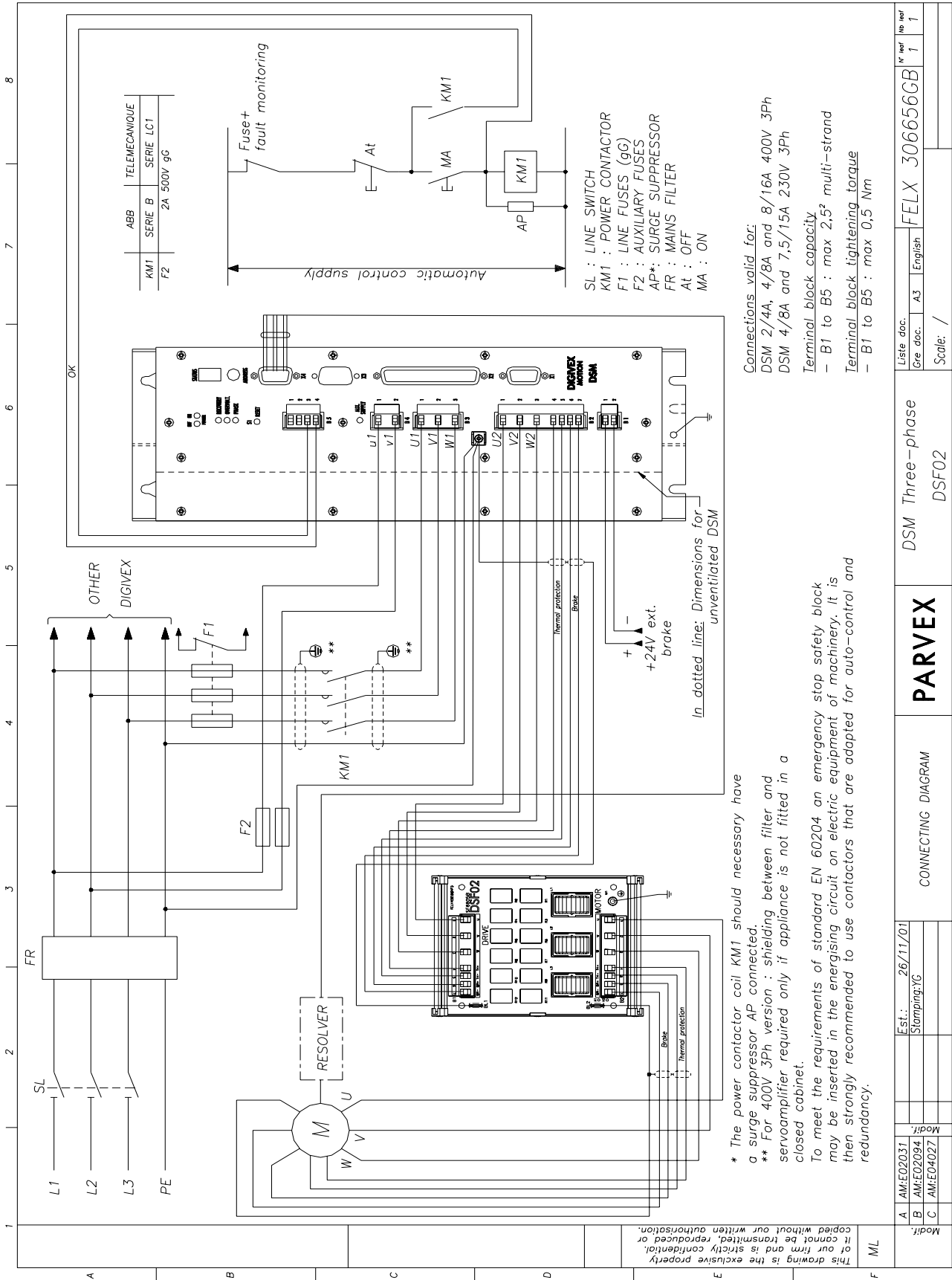

Connection cable between DSM and DSF02

### 6.3.7 Holding brake connection

Brushless motors can be equipped with a specially sized brake to maintain the axis immobilized. If 24 V  $\pm$ 10% dc voltage is applied across the brake terminals, the brake disc is free and the motor can rotate.

The 24 V dc supply used for brake control must be regulated and filtered. It is to be connected to terminal block B1. The brake is to be connected to terminals B2/6 and B2/7.

### 6.3.8 Thermal protection connection

The two terminals of the thermal sensor located in the motor terminal box are to be connected to B2/4 and B2/5.

### 6.3.9 Motor fan connection

Some motors can be supplied in the fan-cooled version.

Motor fan characteristics:

- Supply voltage: 400 V or 230 V three-phase 50/60 Hz.
- Power consumption: 45 W
- Connection by connector (plug 220056P0200 supplied on request).

When connecting, check the direction of fan rotation and that air actually flows. The direction of circulation is shown in the dimension drawings.

#### Connector removable plug

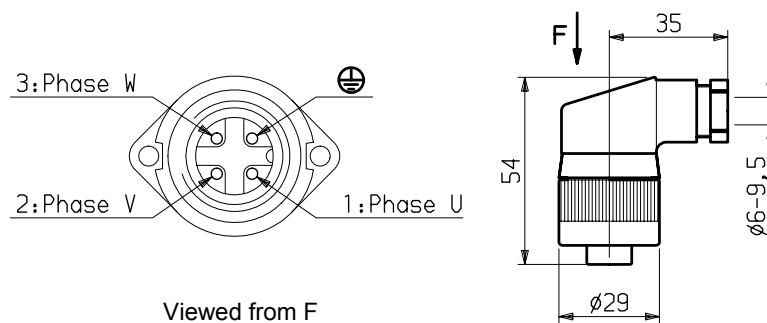



## 6.4 Resolver connection

### 6.4.1 Description

The resolver is a high-precision sensor ( $\pm 10$  angular minutes as standard) which must be wired carefully:

- Routed separately from the power cables.
- Cable twisted and shielded in pair (sine, cosine, excite). The three shieldings must be connected to the metal-plated Sub-D connector cover. Do not connect the shieldings at the motor end.

Parvex. can supply this cable in either of two forms:

- Separate cable, in this case wire as in the drawing below.
- Cable fitted with Sub-D plug at the drive end and connector at motor end. This solution is **highly recommended** as the cable is ready for use.

Maximum distance between the resolver and the DSM: 200 m (Please ask about greater distances).

Maximum permissible cross-section:

- by the Sub-D connector: 0.5mm<sup>2</sup>.
- by the connector removable plug: 0.14 to 0.5mm<sup>2</sup> (solder- or crimp-fit contacts)

**RESOLVER CONNECTOR REMOVABLE PLUG** (motor end connector)  
 220065R4621 (solder-fit contacts - standard)  
 220065R1621 (crimp-fit contacts)

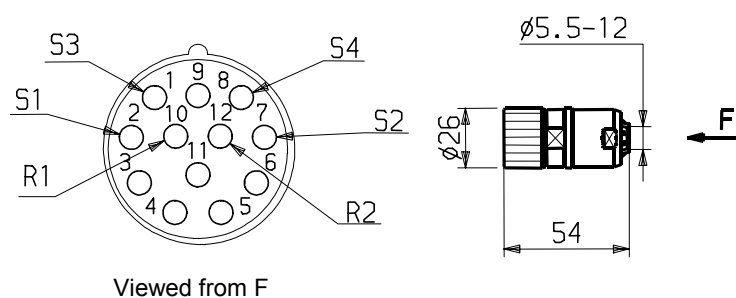

#### **For XD motors :**

Connect by Sub-D connector under rear cover (cable routed through special cable gland).

Please ask for details.

### 6.4.2 Sub-D connector X4:"Resolver"

Digivex end connections, Sub-D 9 pin connector item ref. X4 "RESOLVER".  
Maximum conductor cross-section: 0.5 mm<sup>2</sup>

CONTACT	TYPE	FUNCTION
1	Input	Cosine S1
2	Input	Sine S2
3	Input	Cosine S3
4	Input	Sine S4
5	Output	Excitation R1
6	-	Unused
7	-	Unused
8	-	Unused
9	Output	0V Excite R2/3

### 6.4.3 Cables

Cables by meter: product number : 6537P0001

Complete cables (fitted with plug at the motor end and SUB-D connectors at the DSM end)

product number 220049R61xx (xx : length in metres  
5m/10m/15m/25m/50m).

# DIGIVEX Single Motion (DSM) Servoamplifier

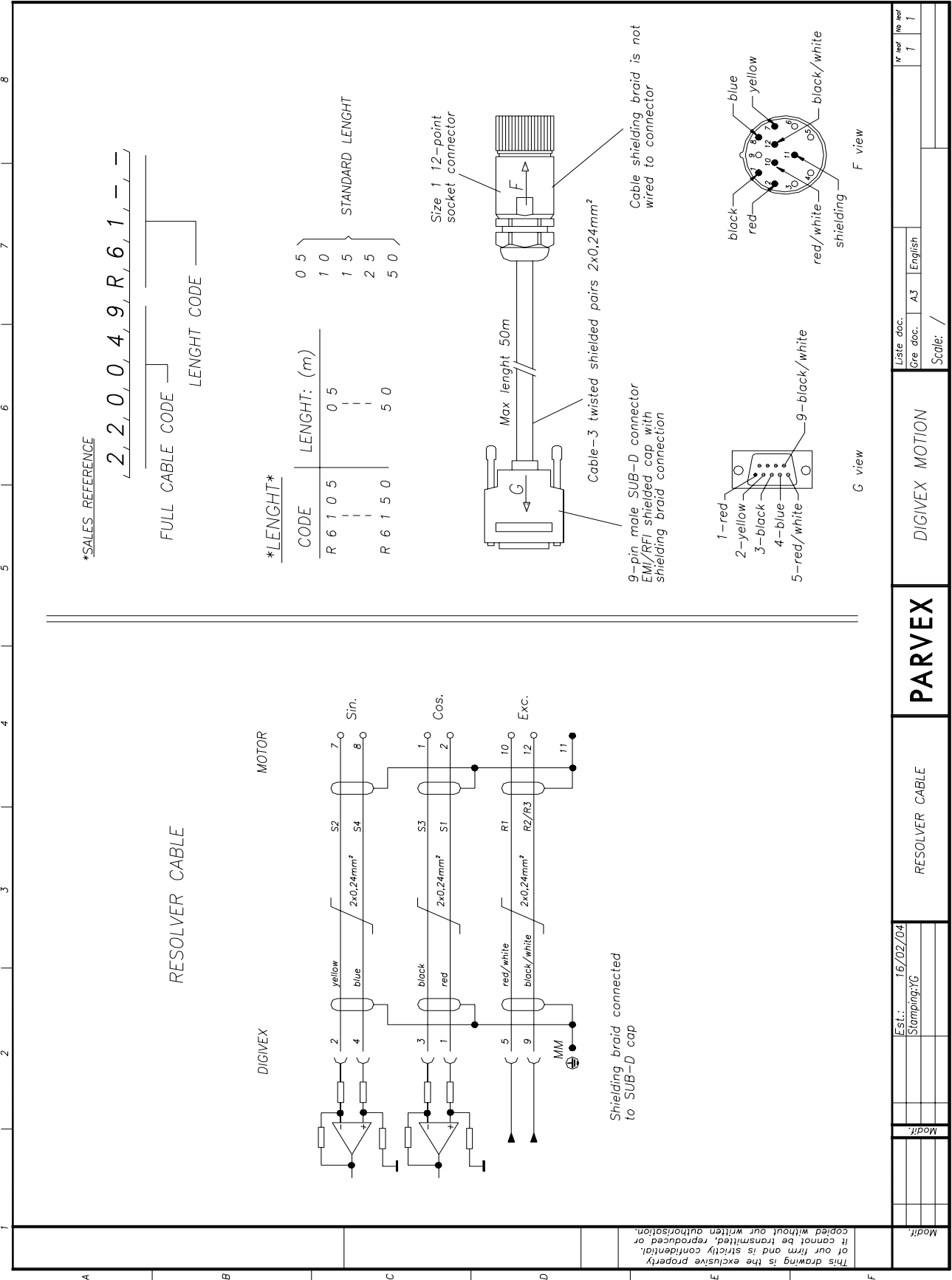

## 6.5 FIELDBUS Connections

---

### 6.5.1 SUB-D X1 plug : FIELDBUS

Identify the nameplate on the front end :

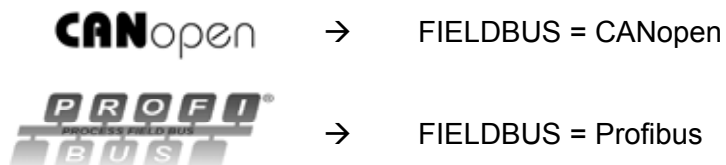

### 6.5.2 CANopen connections and cables

See DIGIVEX Motion - CANopen manual : PVD 3518

### 6.5.3 Profibus connections and cables

See DIGIVEX Motion - Profibus manual : PVD 3554

## 6.6 Input/Output connection

### 6.6.1 SUB-D X2 socket: Inputs/Outputs

CONTACT	TYPE	FUNCTION	CHARACTERISTICS
1 2 20	0 V -12 V +12 V	Symmetrical supply available for analogue I/O	Max. current available = $\pm 50$ mA
3 21	outa 0 V	$\pm 10$ V analogue output	Analogue conversion: $\approx 9$ bits+sign Output $\pm 10$ V / 3 mA Protected against short circuits
4 22	ina + ina -	$\pm 10$ V analogue input	Analogue conversion: 13 bits + sign Differential input
28 10	+ 24V 0V (1)	+24 V input for logic output supply 0V logic outputs	max. 400 mA for 8 outputs Internally connected to X2-7 and X2-23
9 27 8 26 7	out 0 out 1 out 2 out 3 0V (1)	Logic outputs Logic outputs Logic outputs Logic outputs 0V logic outputs	24 V PNP, optocoupled, max. 50 mA outputs, protected against short circuits Internally connected to X2-10 and X2-23
25 6 24 5 23	out 4 out 5 out 6 out 7 0V (1)	Logic outputs Logic outputs Logic outputs Logic outputs 0V logic outputs	24 V PNP, optocoupled, max. 50 mA outputs, protected against short circuits Internally connected to X2-7 and X2-10
37 18 36 17 35 16 34 15 19	in0 in1 in2 in3 in4 in5 in6 in7 COM0	Logic input Logic input Logic input Logic input Logic input Logic input Logic input Logic input Common for inputs in0-in7	Optocoupled logic inputs, type 1 under IEC 1131-2
33 14 32 13 31 12 30 11 29	in8 in9 in10 in11 in12 in13 in14 in15 COM1	Logic input Logic input Logic input Logic input Logic input Logic input Logic input Logic input Common for inputs in8-in15	Optocoupled logic inputs, type 1 under IEC 1131-2

## 6.6.2 Input/Output characteristics

### 6.6.2.1 Logic outputs (out0 - out7)

- opto-mos outputs (2.5 kV isolation voltage), 24 V dc / 50 mA,
- PNP-type static outputs (load connected to negative supply pole) with diode in parallel on load and protection by current limitation,
- an output is said to be at 1 if it is activated (24 V dc output),
- user must provide 24 V dc supply for outputs (18 V ac rectified, filtered),
- 24 V dc supply input protected against reversals of polarity (diode).

	MIN	TYPICAL	MAX
Supply voltage	5 V	24 V	40 V
Output current (level 1)	0.05 mA	-	50 mA
Residual current (level 0)	-	-	0.001 mA
Response time T <sub>on</sub> (0-1)	-	0.3 ms	1 ms
Response time T <sub>off</sub> (1-0)	-	0.2 ms	1 ms
Output voltage drop I = 50 mA	-	-	2 V

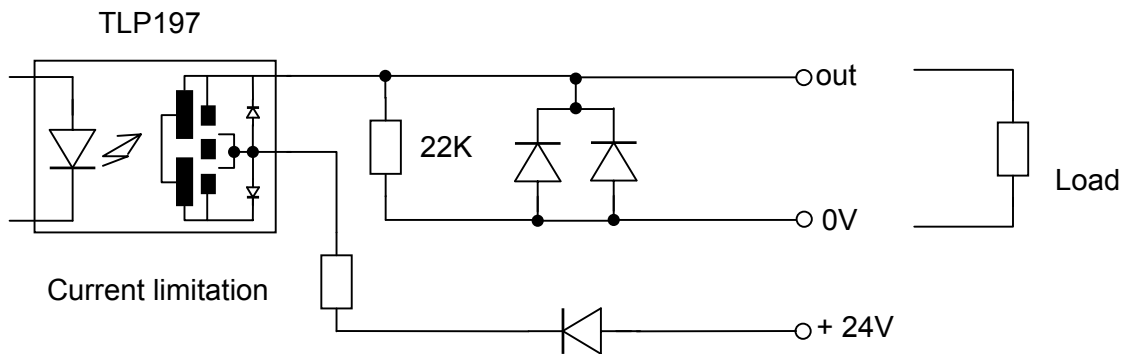

### 6.6.2.2 Analogue output (outa)

- Analogue output : +/-10V  
 Resolution : ≈ 10 bits (9 bits + 1 sign bit)  
 Maximum output current : 5 mA (minimum load 2 K)  
 Source impedance : 100 ohms

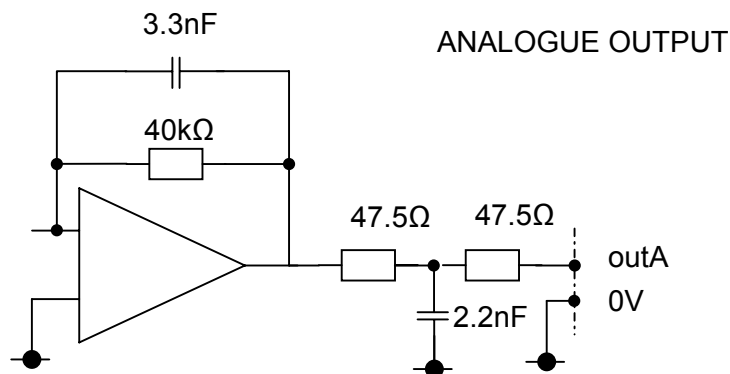

**6.6.2.3 Logic inputs (in0 - in 15)**

- opto-coupled 24V dc inputs (5 kV isolation voltage),
- type 1 inputs under IEC 1131-2,
- input load resistance: 10 K,
- an input is said to be at 1 if it is activated (24 V dc output). Otherwise it is said to be at 0,
- inputs may be connected directly to PNP type outputs (no external load resistor required),
- possibility of connecting 24 V dc "NC (normally closed) or NO (normally open) inductive proximity detectors : 3-lead, PNP output type (load connected to negative supply pole

	MIN	TYPICAL	MAX
Input voltage (level 0)	-	0 V	5 V
Input voltage (level 1)	15 V	24 V	30 V
Input current (level 0)	-	0 mA	0.5 mA
Input current (level 1)	3 mA	7 mA	10 mA
Response time $T_{on}$ (0-1) Inputs In0-In3	-	0.2 ms	-
Other inputs (in4-in15)	-	1 ms	-
Response time $T_{off}$ (1-0) Inputs In0-In3	-	0.2 ms	-
Other inputs (in4-in15)	-	1 ms	-

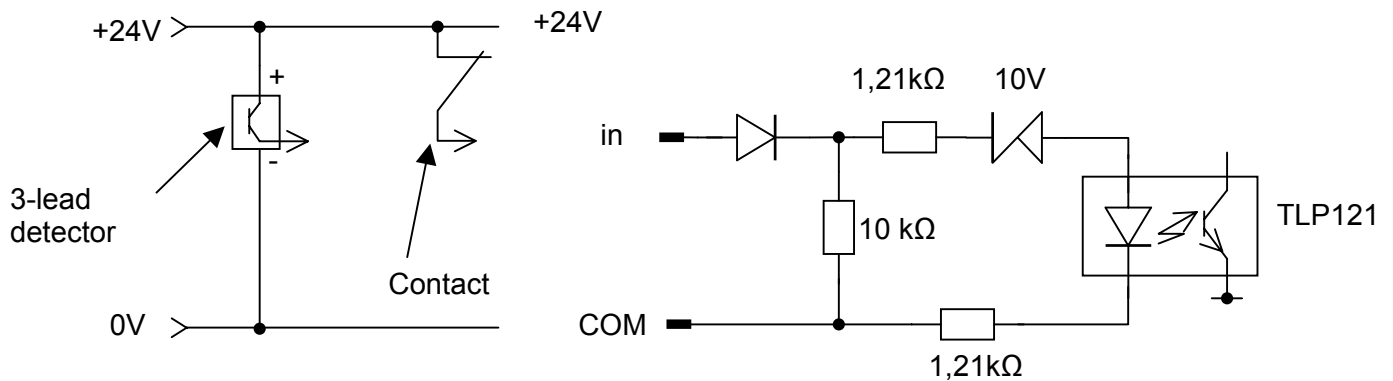

### 6.6.2.4 Analogue input (ina)

- Differential input : +/-10V
- Resolution : 14 bits (13 bits + 1 sign bit)
- Input impedance : >40k $\Omega$
- Maximum consumption on +12 V : 10 mA max.
- Maximum consumption on -12 V : 10 mA max.

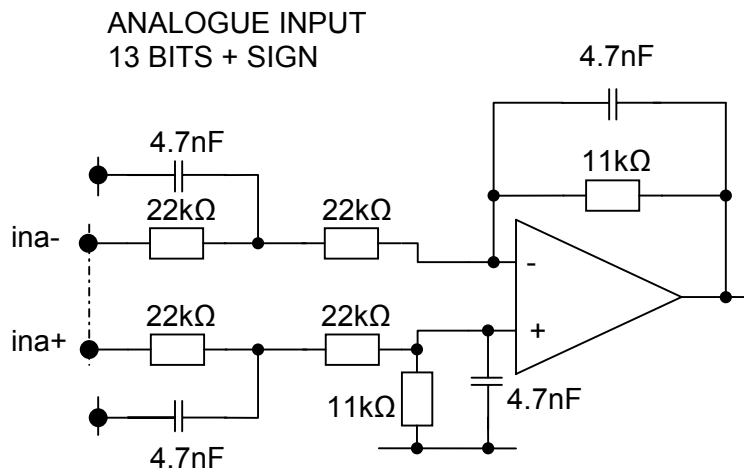

### 6.6.3 Cable

Loose cables: product number : CB 08304

Complete cables: product number : CYB04559R1 xx (xx : defines the length in m) (equipped with SUB-D connectors). See drawing FELX 305974.

Product number of cable supplied by metre by Parvex: product number CB08307



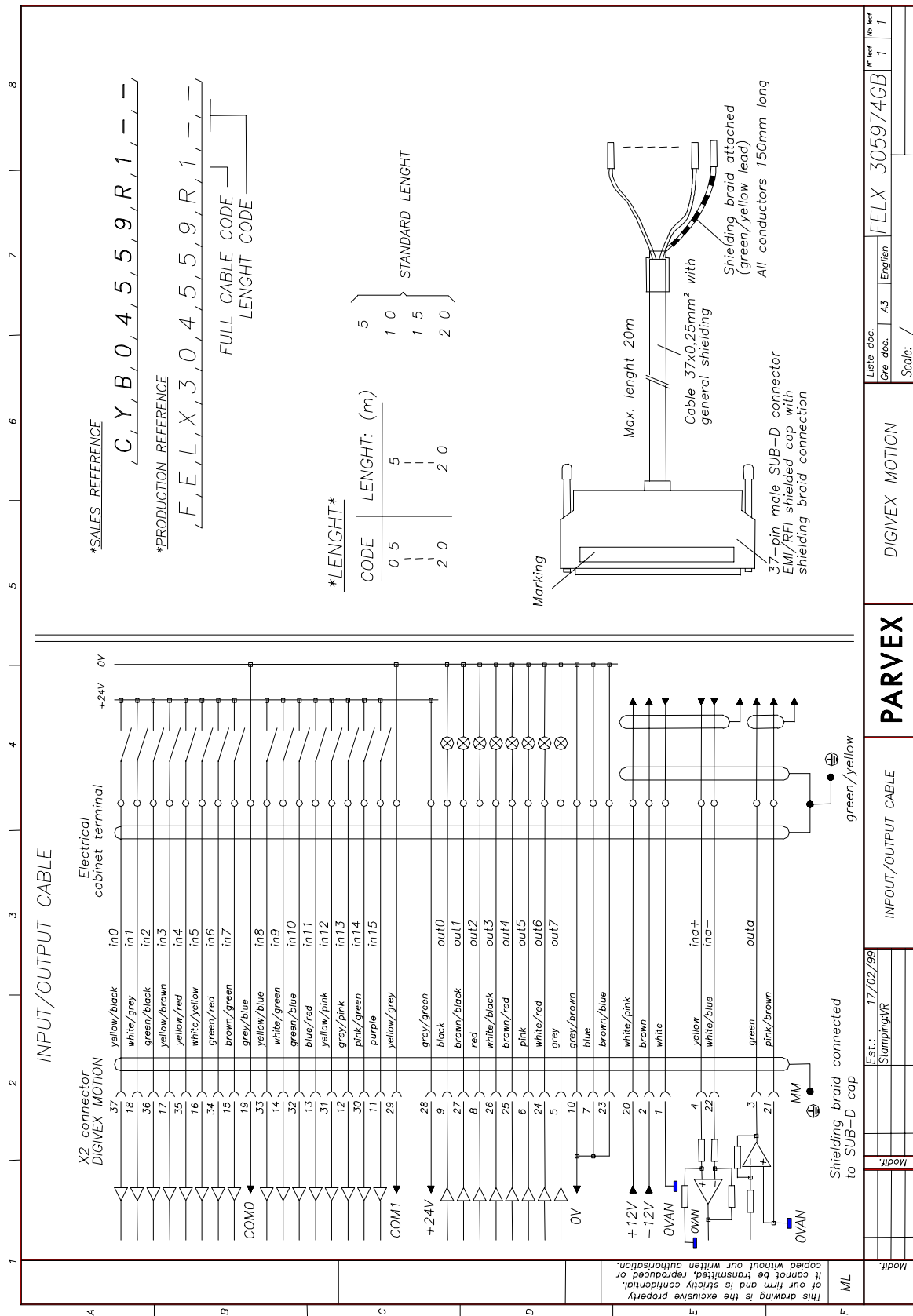

Est.: 17/02/99	StampingVR	Modif:
INPOUT/OUTPUT CABLE	PARVEX	DIGIVEX MOTION
Doc. No. 305974GB	Rev. 1	Scale: /

## 6.7 Encoder emulation option connection (SC6639)

### 6.7.1 Description

This optional board, fitted in the DSM, converts the signal from the resolver into a series of pulses identical to those from an incremental encoder: A, B, Zero Mark and their complements.

### 6.7.2 Sub-D connector X3: encoder emulation option

Sub-D 9-pin plug, "Encoder". Maximum conductor cross-section: 0.5 mm<sup>2</sup>.

CONTACT	TYPE	FUNCTION	Characteristics
5	Input	5V	Max. current = 100 mA
9	Input	0V	
7	Output	A	Encoder channel A
3	Output	$\bar{A}$	Encoder channel $\bar{A}$
8	Output	B	Encoder channel B
4	Output	$\bar{B}$	Encoder channel $\bar{B}$
6	Output	zero mark	Encoder channel zero mark
2	Output	$\overline{\text{zero mark}}$	Encoder channel $\overline{\text{zero mark}}$

### **6.7.3 Programming resolution and zero mark position**

This is done with the PME DIGIVEX-MOTION. (See the Manual PVD3516)

These parameters can be called up by selecting the "Input/Output parameters menu with the "options" tab.

#### **Resolution**

Adjustable between 1 and 16384, either by +/- keys, or by entering the number directly (in "OFF LINE" mode only).

#### **Zero Mark Setting**

Adjust by trial-and-error with the PC working in "ON LINE" mode.

When the operator judges the position is suitable, he confirms by acknowledging the zero mark.

### **6.7.4 Electrical characteristics**

The electrical output interface meets standard RS422 for differential serial links. The circuit used is a "LINE DRIVER" of the 26C31 type. The electrical characteristics are therefore closely related to the use of this component.

#### **Voltage supply**

The encoder emulation boards are electrically isolated between the output stage through three optocouplers, needing to be powered by an external +5V  $\pm 10\%$ , 100 mA source, as for all incremental encoders.

In no case can this power supply, which is intended only for electrical isolation, be used to keep position information from the resolver in the event of failure of the drive's low-level power supply.

#### **Short-circuit capability**

A single output may be short-circuited at 0 V at any given time

## Signal form

Signal levels:

- $U_{high} \geq 2.5V$  for  $I_{high} \geq -20mA$
- $U_{low} \leq 0.5V$  for  $I_{low} \leq 20mA$

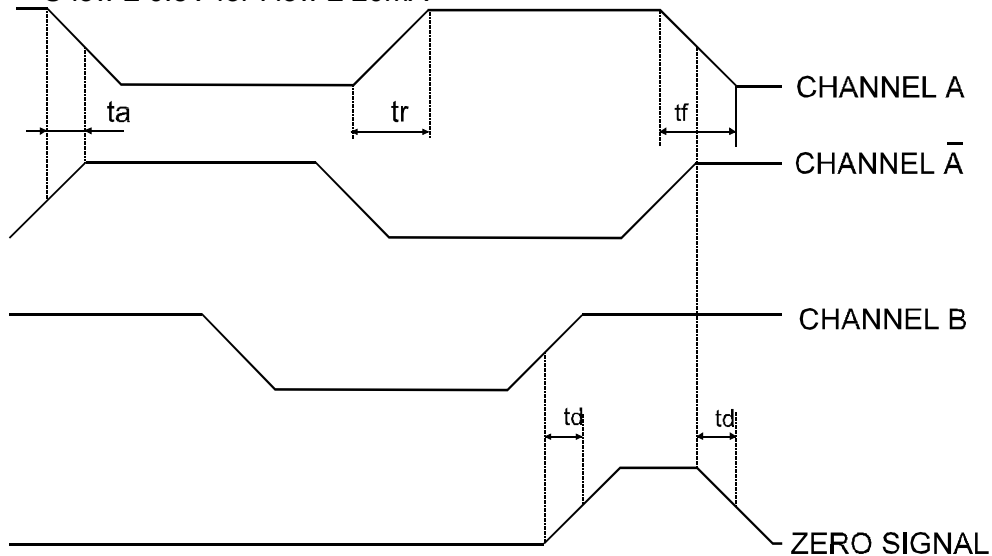

## Switching time:

Rise or fall time defined from 10% to 90% of the magnitude in question, without cable and without load.

$$t_r = t_f = 45ns \text{ (typical value)}$$

## Time delay between direct and complemented channels

Time delay defined at 50% of magnitudes in question without cable and without load.

$$-6ns \leq t_d \leq 6ns \text{ (maximum)}$$

**maximum frequency** : 500 kHz on signals A or B

## DIGIVEX Single Motion (DSM) Servoamplifier

Time interval between channels A, B and the zero mark

Time delay defined at 50% of magnitudes in question without cable and without load.

$$-6\text{ns} \leq t_d \leq 6\text{ns} \text{ (maximum)}$$

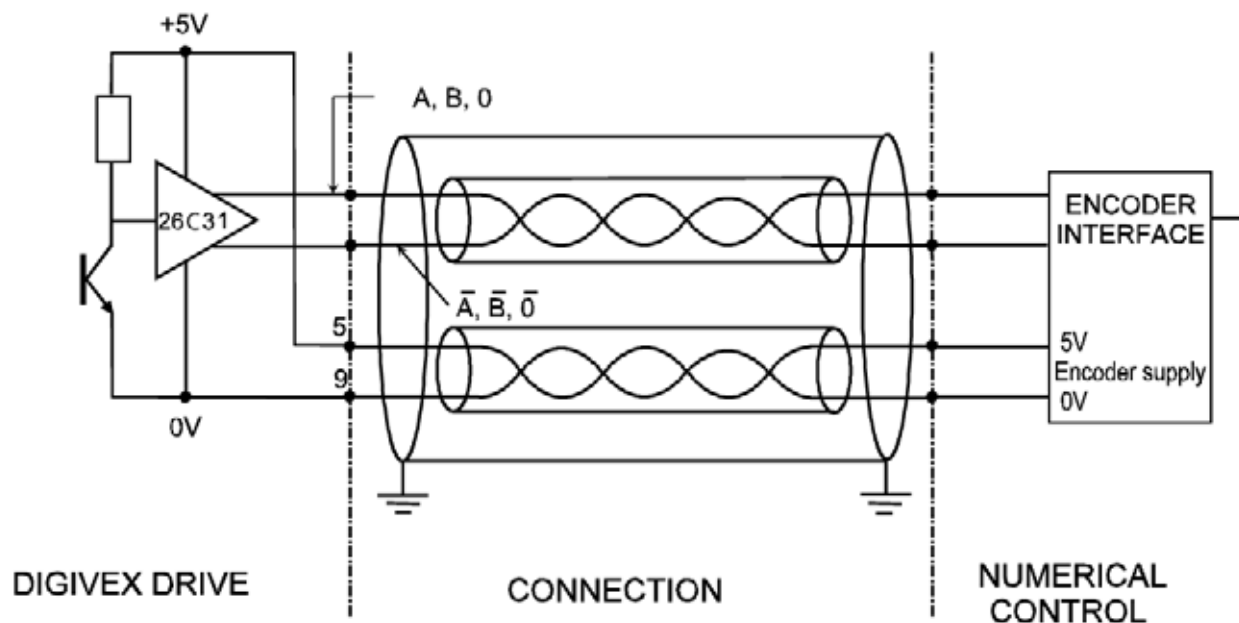

### 6.7.5 Cable

Cable can be supplied with SUB-D connectors, see drawing FELX 304554.

Product number    DIG 04546R1xx (2 SUB-D connector)  
                          DIG 04546R2xx (1 SUB-D connector)  
                          (xx : defines length in metres)

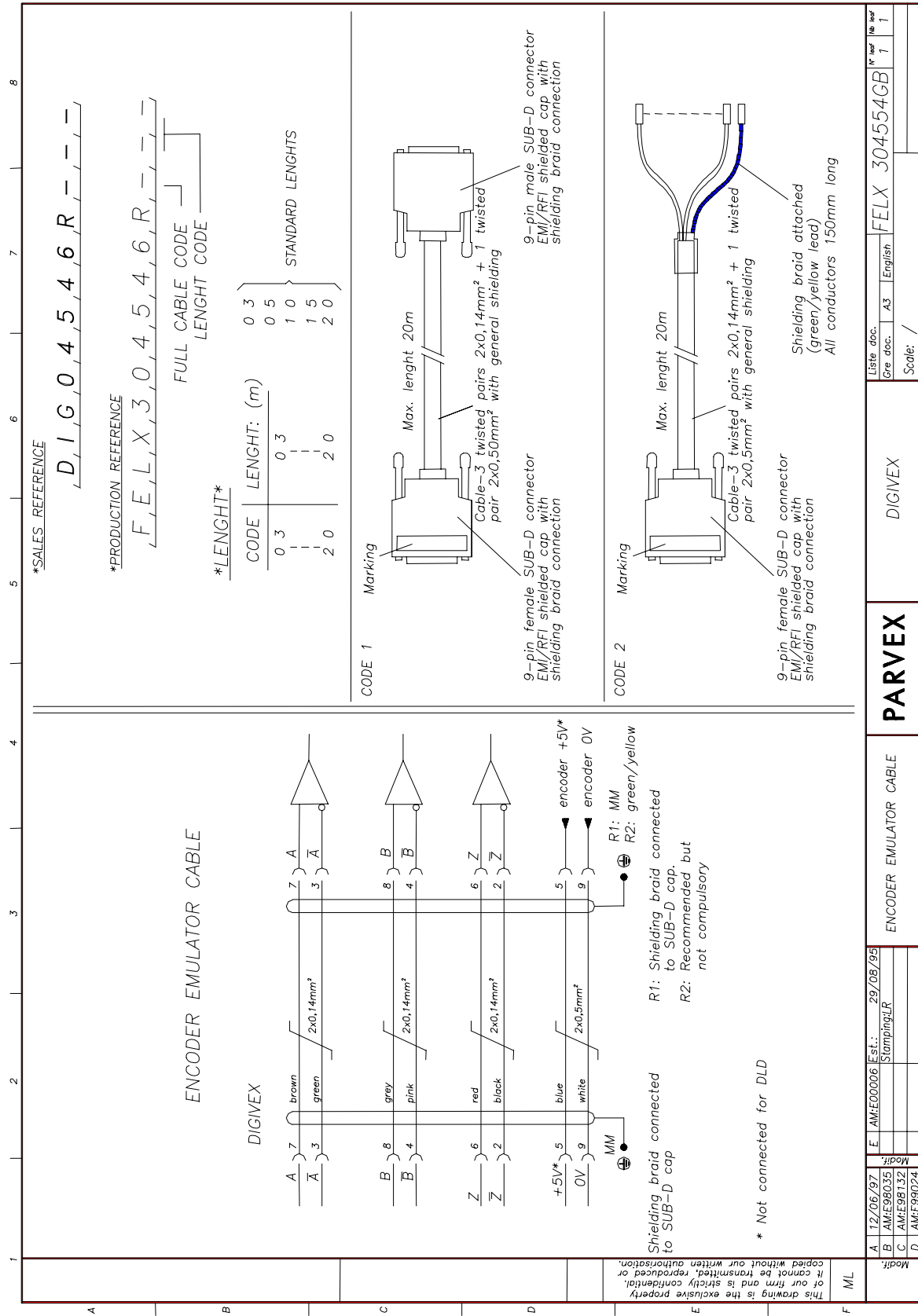

## 6.8 External encoder input option connection (SC6638)

### 6.8.1 Description

This option board, placed in the DSM, is used to connect an external incremental encoder which may be used:

- either as a master axis for synchronization with an external moving component, or as a cam type function
- or as a position measuring device if position measurement given by the resolver is unsuitable  
Caution: in this case, the resolver must be connected nevertheless.
- or as a position measuring device for refined applications where allowance must be made for position on the part and not on the motor  
Caution: in this case, the resolver must be connected nevertheless.
- or as an automatic control and a position measuring device  
Caution: in this case, the motor shaft must be mechanically free so that the motor can be polarized using user program as Motor\_polarization.bdm which is to be found under : C:\Program Files\Parvex\Pme4.xx\App\_Parvex\Samples\Misc\. The drive in7 input and out7 output are assigned to this program :
  - in7 = 1 authorizes the polarization phase to start.
  - out7= 1 when the polarization phase is completed.This program is only given as an example and can be modified according to the customer application.

The position sensor must be an incremental encoder type, with complemented track, with a line driver:

- tracks A,  $\bar{A}$ , B,  $\bar{B}$ , zero mark,  $\overline{\text{zero mark}}$
- supply +5 V
- maximum consumption 250 mA
- maximum frequency: 250 kHz on signals A or B
- Encoder +5V supply voltage is provided by the DSM from a +24V DC external supply.

### 6.8.2 SUB-D X3 sockets: encoder input option

CONTACT	TYPE	FUNCTION	Characteristics
5	Output	5V	max. 250 mA encoder supply Output ⚠ : + 24 V supply to sockets X2-28 / X2-10 is required for encoder supply
9	Output	0V	
7	Input	A	Encoder channel A
3	Input	$\bar{A}$	Encoder channel $\bar{A}$
8	Input	B	Encoder channel B
4	Input	$\bar{B}$	Encoder channel $\bar{B}$
6	Input	Zero mark	Encoder channel zero mark
2	Input	$\overline{\text{zero mark}}$	Encoder channel $\overline{\text{zero mark}}$

### 6.8.3 Cable

The DSM-Encoder connection cable shall be made up of three twisted pairs of cross-section of 14 mm<sup>2</sup> or more (for signal transmission) and one larger pair (for encoder supply).

Encoder supply cable cross-section:

- 20 m cable 150 mA current → 0.5 mm<sup>2</sup>
- 35 m cable 150 mA current → 1 mm<sup>2</sup>
- 10 m cable 200 mA current → 0.5 mm<sup>2</sup>
- 20 m cable 200 mA current → 1 mm<sup>2</sup>
- 50 m cable 200 mA current → 2.5 mm<sup>2</sup>
- 10 m cable 250 mA current → 0.75 mm<sup>2</sup>
- 20 m cable 250 mA current → 1.5 mm<sup>2</sup>
- 40 m cable 250 mA current → 2.5 mm<sup>2</sup>

Some of the cross-sections defined above are difficult to wire to a SUB-D connector, in which case the following wiring arrangement may be used.

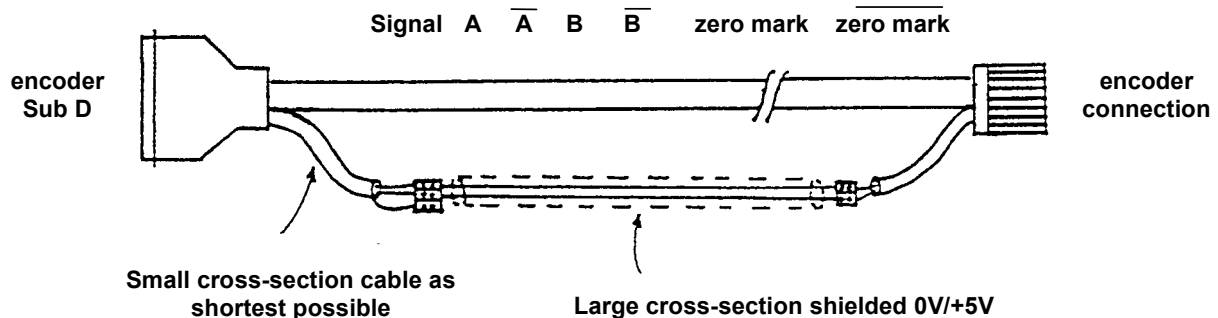



## DIGIVEX Single Motion (DSM) Servoamplifier

---

For higher values an external +5V supply must be installed near to the encoder to prevent voltage loss over long lengths of cable.

Input interface :

Input voltage	MIN.	MIN	TYPYCAL	MAX
level 0		-	0 V	1 V
level 1		3 V	5 V	5.5 V

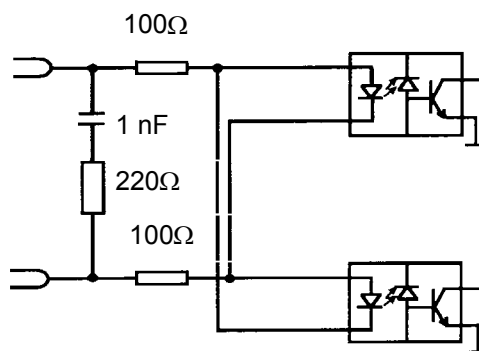

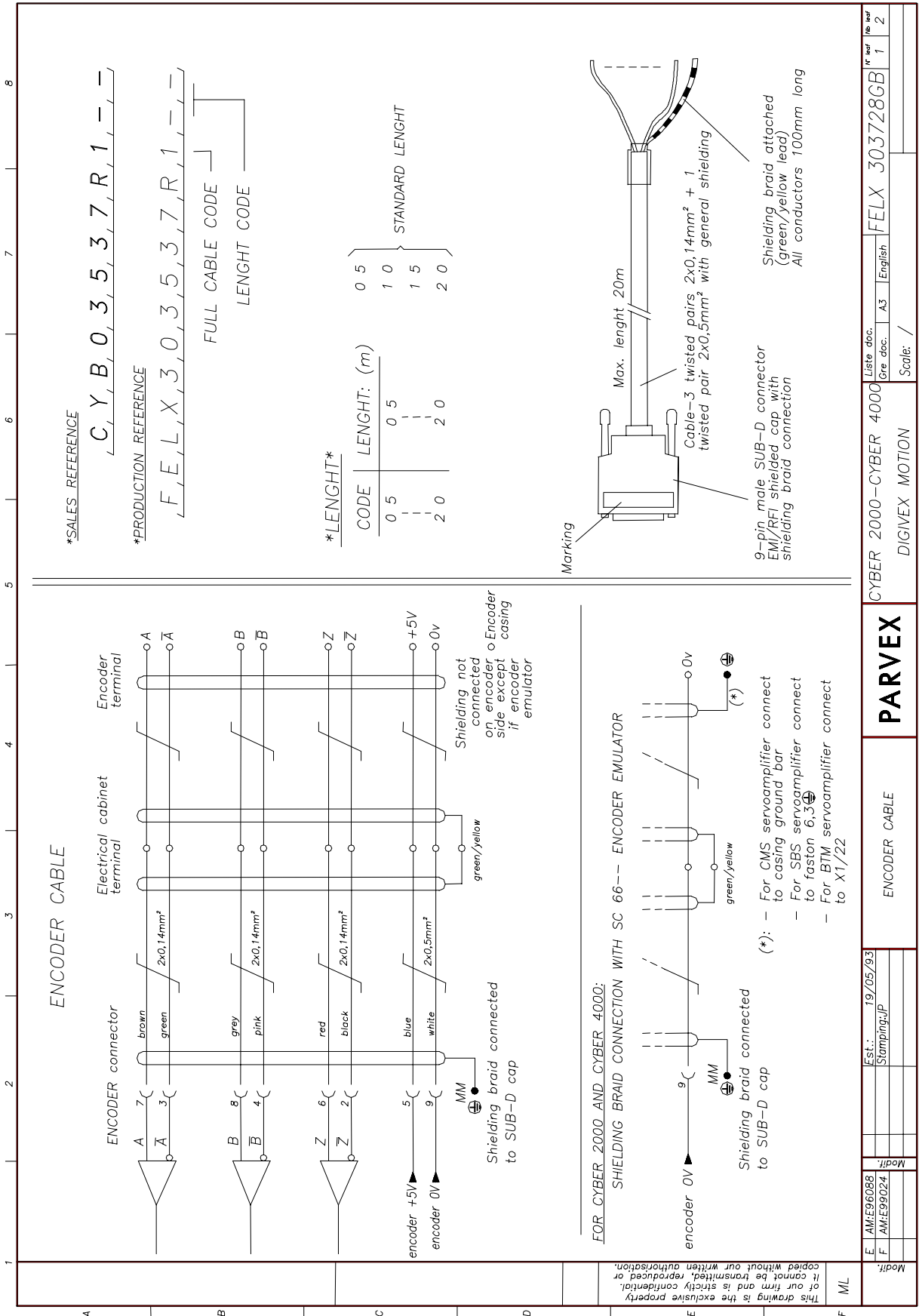

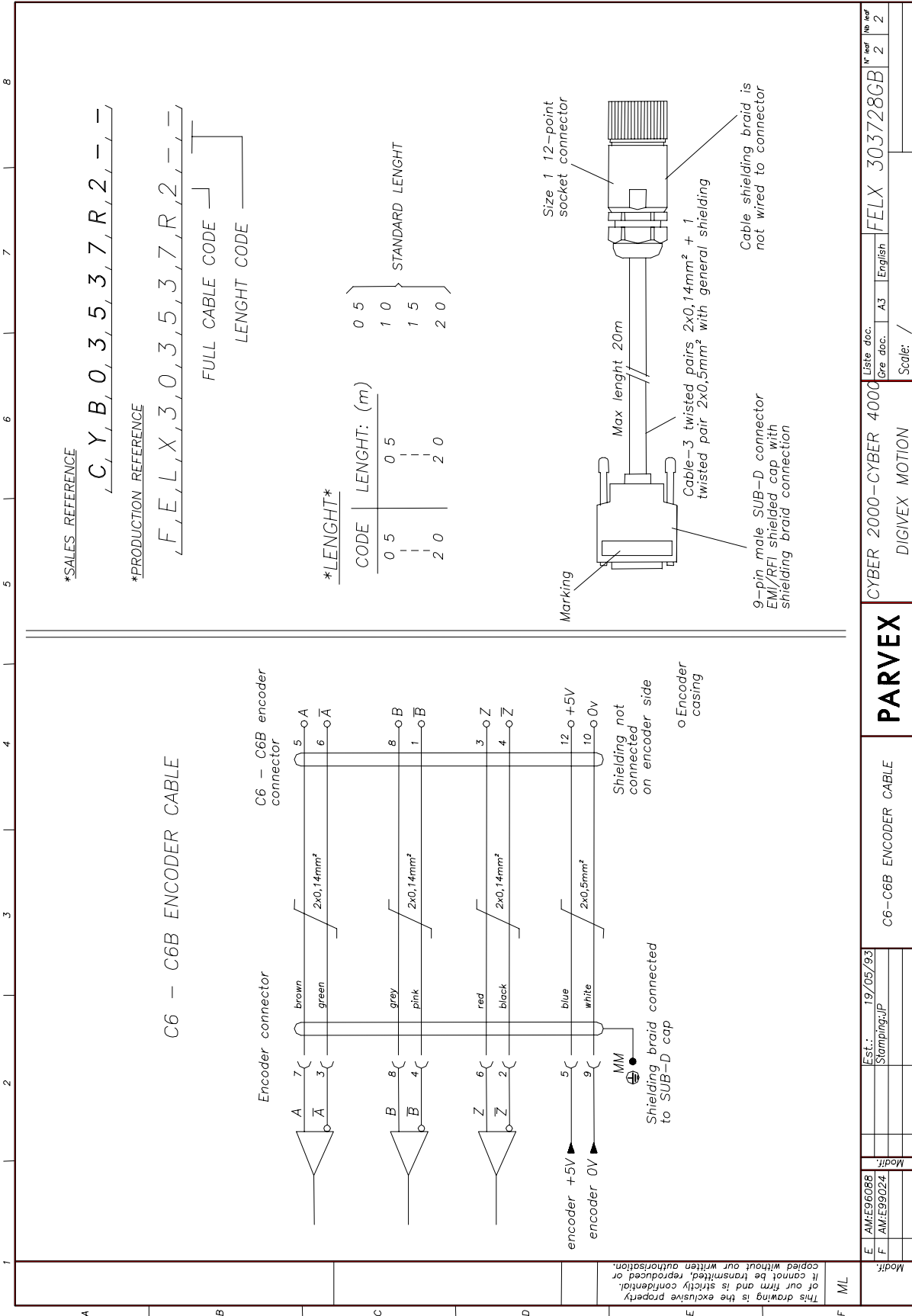

This drawing is the exclusive property of our firm and is strictly confidential. It cannot be transmitted, reproduced or copied without our written authorisation.

## 6.9 Connecting the SinCos encoder input option (SC6645)

---

### 6.9.1 Description

This optional card, placed in the DSM, is used to connect a SinCos encoder which acts as an automatic motor and position measurement control unit for applications requiring both rotation speed and significant resolution.

Attention: in this case, the motor shaft must be mechanically free so that the motor can be polarized using a user program w as Motor\_polarization.bdm which is to be found under C:\Program Files\Parvex\Pme4.xx\App\_Parvex\Samples\Misc\.

The input (in7) and the output (out7) are assigned to this program:

- in7 = 1 authorizes the polarization phase to start.
- out7= 1 when the motor polarization phase is completed.

This program is only given as an example and can be modified according to the customer application.

In addition, a program available under PME (Parameter editor -> Motor/Resolver -> Setting SinCos encoder parameters) can be used to equalize any SINE and COSINE channel offsets as well as any differences in amplitude between the same channels.

The resolution obtained via the SinCos encoder is given by the formula:

**RESOLUTION = NUMBER OF ENCODER PERIODS OF SINE X INTERPOLATION FACTOR**  
with the INTERPOLATION FACTOR being approx. equal to 512 points; the interpolation factor is the breakdown of a sinusoidal signal as a given number of points.

The position sensor should be a SinCos encoder with sinusoidal outputs:

- Tracks A,  $\bar{A}$ , B,  $\bar{B}$ , Top0,  $\overline{\text{Top0}}$  (analog).
- 2 signals, A and B, in quadrature and their inverted signals  $\bar{A}$   $\bar{B}$ , being short circuit resistant.
- Maximum number of authorized encoder periods of sine: 65536 periods/revolution.
- Level of differential peak to peak voltages A  $\bar{A}$  and B  $\bar{B}$  between 0.8 V (AC) and 1.1 V (AC).
- Power supply +5V.
- Maximum consumption 250 mA.
- Maximum frequency: 200 kHz for the A or B signals.
- An external 24V +/- 10% power supply must be provided to supply the SC6645 option card via the DSM SUB-D X2 (Contact 28: + 24V, Contact 10: 0V). An isolated DC-DC converter (24V /5V), on the option card is used to supply the encoder with 5V.  
Attention: The external power supply needs to be 24V DC +/- 10%.

**6.9.2 SUB-D X3 plug: Encoder input option.**

CONTACT	TYPE	ROLE	Characteristics
5	Output	5V	Encoder power supply: maximum output 250 mA. ⚠: a +24V power supply for X2-28 / X2-10 plug is required for processing the encoder power supply
9	Output	0V	
7	Input	A	Encoder channel A SINE signal (differential inputs)
3	Input	$\bar{A}$	Encoder channel $\bar{A}$
8	Input	B	Encoder channel B COSINE signal (differential inputs)
4	Input	$\bar{B}$	Encoder channel $\bar{B}$
6	Input	Top 0	Encoder channel Top 0 (differential inputs)
2	Input	$\overline{\text{Top 0}}$	Encoder channel $\overline{\text{Top 0}}$

**6.9.3 Cables**

The DSM connection cable should be made up of 4 twisted pairs, shielded in pairs, with sections greater than or equal to 0.25 mm<sup>2</sup>.

The maximum cable length is 40 m. Please consult us for information on longer cable lengths.

There is an approved PARVEX cable for controlling with SinCos encoder.

Input interface:

**The input signals for the encoder input card should be sinusoidal and differential with peak to peak values between 0.8 V and 1.1 V.**

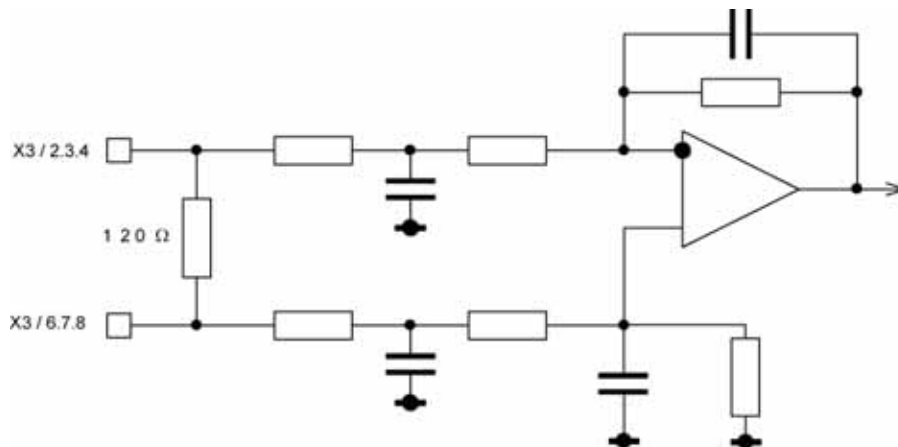

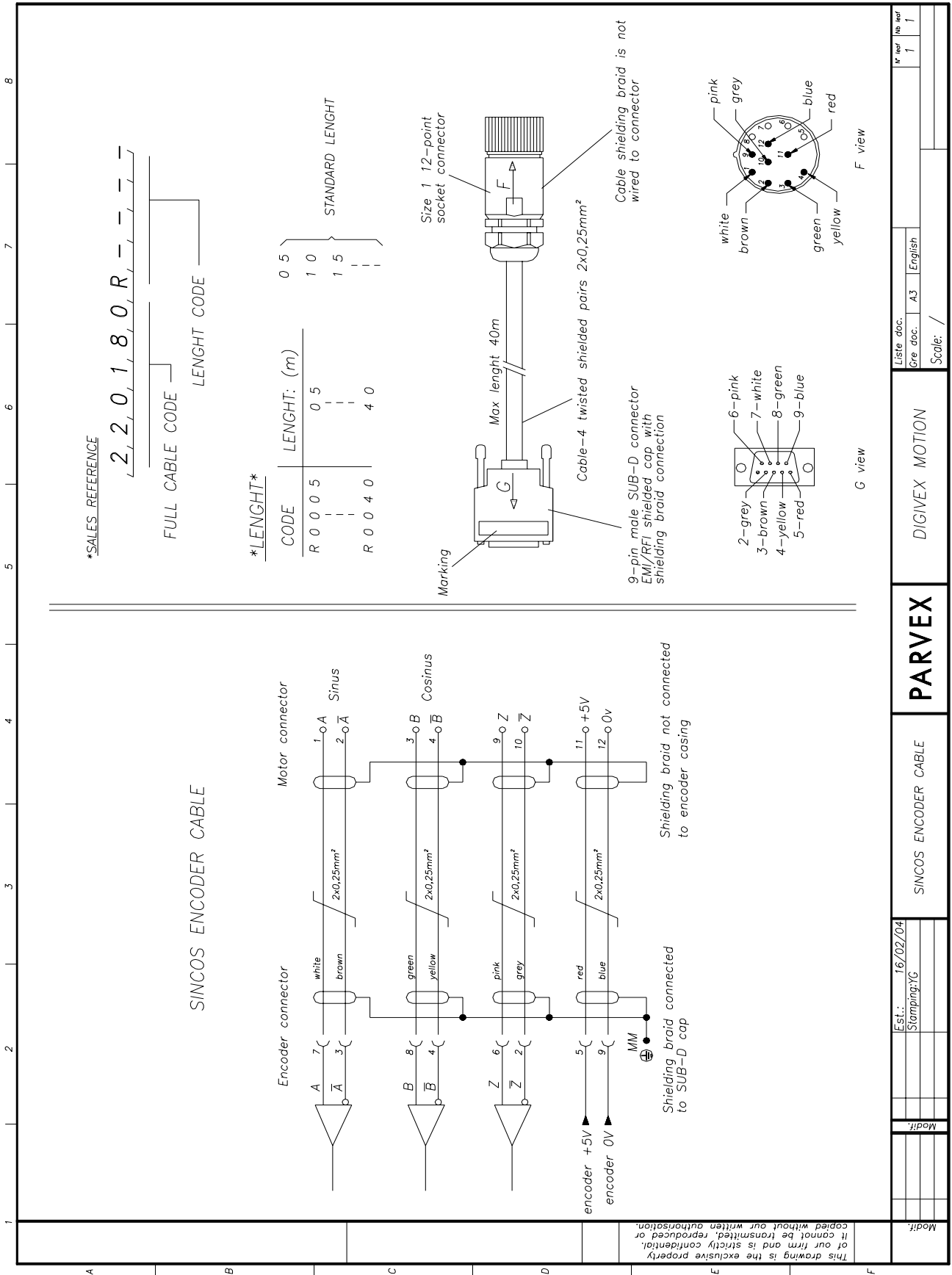

Liste abc.	Gre abc.	A3	English	No part	No part
				1	1
				Scale: /	
<b>PARVEX</b>			DIGIVEX MOTION		
SINCOS ENCODER CABLE					

## 6.10 External braking resistor connection

### 6.10.1 Description

*This feature applies to 60/100 - 230 V three-phase and 32/64 - 400 V three-phase supplies only.*

Use with internal resistor: short-circuit B6/2 and B6/3 with a 4 mm<sup>2</sup> isolated cable. B6/1 is not connected.

Use the external resistor: connect the external resistor between B6/1 and B6/2. The B6/3 terminal is not connected.

Maximum current in cable:

- With RE 91001 (2000 W): 26 A for the 32/64 A, 400 V three-phase module.
- With RE 91002 (4500 W): 31 or 62 A (see page 21) for the 60/100 A, 230 V three-phase module.

Cable type: unshielded, cross-section 2.5 mm<sup>2</sup> for 2000 W, 4 mm<sup>2</sup> for 4500 W.

Maximum recommended distance: 10 m.

Resistor end: Connection via terminal block via packing gland PG 16, for cable diameters between 10 mm and 14 mm.

### 6.10.2 Terminal block B6

**Description of module terminal blocks: 230V three-phase 60/100A  
400V three-phase 32/64A**

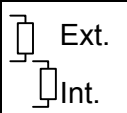
ITEM REF.	TERMINAL	Front Panel Marking	FUNCTION	TERMINAL BLOCK TYPE	TERMINAL CAPACITY
B6/1 B6/2 B6/3	 Ext. Int.	RECOVERY	Internal / external resistor connection	No unpluggable screw-type	<u>32/64 and 60/100</u> Min 0,2 mm <sup>2</sup> Max flexible lead 4 mm <sup>2</sup>

## 6.11 Brake supply connection

### 6.11.1 Description

This terminal block may receive 24 V supply voltage for the brake mounted on the motor. It is supplied at the motor terminal block B2.

Regulated / filtered 24 V  $\pm 10\%$  voltage. Protection against overvoltage by 26 Joule varistor, this protection is effective from 30 V.

### 6.11.2 Terminal block B1

Description of module terminal blocks: 230V single-phase 2/4, 4/8, 7.5/15A  
 230V three-phase 4/8, 7.5/15, 15/30A  
 400V three-phase 2/4, 4/8, 8/16A  
 400V three-phase 16/32A  
 230V three-phase 30/60A  
 230V three-phase 60/100A  
 400V three-phase 32/64A

ITEM REF.	TERMINAL	Front Panel Marking	FUNCTION	TERMINAL BLOCK TYPE	TERMINAL CAPACITY
B1/1	+24V	BRAKE	24V input for brake supply	Unpluggable screw-type	Min 0,2 mm <sup>2</sup> Max 2,5 mm <sup>2</sup> flexible and rigid lead
B1/2	0V	SUPPLY			



## 7. COMMISSIONING - DIAGNOSTICS

### 7.1 Start-up Sequence

#### 7.1.1 Preliminary checks

**Wiring check**

- Power and auxiliary connections to DSM.
- Reset wiring.
- External 24 V supply for brake.
- Check the resolver connections.
  - ◆ Motor end
  - ◆ DSM end
- Check the power, brake and thermal connections.
  - ◆ Motor end
  - ◆ DSM end

**Supply type check**

- Power: 50/60 Hz, 230 V single or three-phase, 400 V three-phase depending on model.
- Auxiliaries: single-phase 50/60 Hz, 230 V or 400 V depending on model.
- Brake supply: 24 V dc  $\pm 10\%$  (including oscillation).

**Caution:** Before doing any work on the system, make sure the power bus is at 0 V. Wait at least three minutes after the motors have come to a complete stop before starting work. **Wait until all the LEDs have gone out.**

#### 7.1.2 Commissioning with PME-DIGIVEX Motion

See the Manual      PVD3516

### 7.2 Initialization Sequence

After auxiliary power has built up: (approx. 300 ms)

- To                                     $\Leftarrow$  Mains supply present. The "POWER OFF" LED goes out.
- To + Tc                            $\Rightarrow$  capacity precharging internal relay closes and relay "OK" The "POWER ON" led goes on.
- To + Tc + 500 ms                $\Rightarrow$  Motor can be controlled if torque is validated.

DSM 230V SINGLE-PHASE

DSM	2/4	4/8	7,5/15
Tc(ms)	150	300	400

DSM 230V THREE-PHASE

DSM	4/8	7,5/15	15/30	30/60	60/100
Tc(ms)	150	150	300	450	600

DSM 400V THREE-PHASE

DSM	2/4	4/8	8/16	16/32	32/64
Tc(ms)	150	150	300	450	600

## 7.3 Stop Sequence

---

### 7.3.1 Normal stoppage

Normal stoppage is achieved by deliberately opening the main contactor.

To	⇐ contactor opened
To + 10ms	⇒ "POWER OFF" LED comes on
To + 20ms	⇒ OK contact on terminal block B5 opens
To + 20ms + delay	⇒ The motor is no longer controlled after the bus has discharged. The "POWER ON" LED goes out. Discharge time depends on positioner activity during this phase.

### 7.3.2 Stoppage subsequent to mains supply or braking fault

To	⇐ Fault detected
To + 20ms	⇒ The OK contact of terminal block B5 opens and displays the type of fault at the supply side via a set of LEDs. The external automatic control must then open the main contactor at the latest 100 ms after the OK relay opens.
To + 20ms + Tr	⇒ The "POWER OFF" LED lights. (Tr = contactor opening delay).
To + 20ms + Tr + delay	⇒ The motor is no longer controlled after the bus has discharged. The "POWER ON" LED goes out. Discharge time depends on positioner activity during this phase.

### 7.3.3 Stoppage subsequent to motor drive fault

To	⇐ Fault detected
To + 10ms	⇒ The motor is no longer controlled. The 7-segment display shows the fault in question.
To + 20ms	⇒ The OK contact of terminal block B5 opens. The external automatic control must open the main contactor at the latest 100 ms after "OK" opens. After the main contactor opens "POWER OFF" LED comes on.
To + 20ms + delay	⇒ "POWER ON" LED goes off,

N.B. Mains failure entails bus dc voltage discharging two seconds later whatever the stop mode.

## 7.4 Detecting Reasons for Stoppage

### 7.4.1 LED display - power supply function

LED	COLOR	FUNCTION
POWER ON	Green	Power on, with no fault in the supply or in the drive control.
POWER OFF	Red	Auxiliary supply on. No power supply (either because of a fault, or by switching off).
RECOVERY	Red	Either, if temporarily on, normal switch in of recovery resistor Or, if permanently on, recovery fault or resistor short-circuited (valid only for external resistors).
OVER VOLT	Red	Flashing: mains supply overvoltage 480V or 255V Fixed: bus overvoltage 750 VDC or 400VDC
PHASE	Red	No mains power phase.
AUX. SUPPLY	Green	Indicates auxiliary supply is on.

In normal operation, the LED status is as follows:

- POWER ON                      Green
- POWER OFF                    Off
- RECOVERY                      Off
- OVER VOLT                      Off
- PHASE                            Off
- AUX. SUPPLY                  Green

N.B : The Power ON and Power OFF LEDs may come on simultaneously when the power supply is cut out : mains disconnected and intermediate supply greater than minimum voltage (200V for 400Vac models and 100V for 230Vac models).

## 7.5 7-segment display status

Function: To provide information on the DIGIVEX status distinguishing between faults.  
 Description :

Description	Display	status _ number	Status
<i>Stand by without power with execution of application program</i>	0	36	Information
<i>Stand by without power without execution of application program</i>	blinking 0	1	Information
<i>Power present with execution of application program</i>	1	21	Information
<i>Power present without execution of application program</i>	blinking 1	2	Information
<i>Resolver failure</i>	2	3	Major Fault
<i>Encoder fault</i>	blinking 2	37	Major Fault
<i>Excessive ambient temperature</i>	3	4	Major Fault
<i>Excessive heatsink temperature</i>	3	5	Major Fault
<i>High heatsink temperature with reduced current</i>	blinking 3	6	Information
<i>Excessive motor speed (in rpm)</i>	4	7	Major Fault
<i>Excessive application speed (in Units/s)</i>	4	35	Major Fault
<i>Excessive supply current</i>	5	8	Major Fault
<i>Excessive variable speed drive current</i>	6	9	Major Fault
<i>Excessive dl/dt</i>	6	10	Major Fault
<i>Excessive average current</i>	7	11	Major Fault
<i>Excessive RMS current</i>	7	13	Major Fault
<i>Excessive average current with reduced current</i>	blinking 7	12	Information
<i>Excessive RMS current with reduced current</i>	blinking 7	14	Information
<i>Bus overvoltage</i>	8	15	Major Fault
<i>Excessive motor temperature</i>	9	16	Major Fault
<i>Option card fault</i>	11	29	Major Fault
<i>Incompatible Axis/Spindle definition</i>	A	17	Major Fault
<i>CAN or Profibus connection fault</i>	b	18	Major Fault
<i>Motor not connected</i>	C	19	Major Fault
<i>User program memory fault</i>	d	20	Major Fault
<i>Emergency stop</i>	E	38	Major Fault
<i>Personalization board missing</i>	F	22	Major Fault
<i>Axis / personalization board incompatible</i>	F	23	Major Fault
<i>Internal parameter calculation fault</i>	F	24	Major Fault
<i>+ Electrical limit reached</i>	H	25	Minor Fault
<i>- Electrical limit reached</i>	H	26	Minor Fault
<i>+ Software limit reached</i>	L	33	Minor Fault
<i>- Software limit reached</i>	L	34	Minor Fault
<i>Program execution fault</i>	P	27	Minor Fault
<i>Tracking error fault</i>	U	28	Major Fault
<i>C167 CPU Fault</i>	.	31	Major Fault
<i>DSP CPU Fault</i>	. blinking	32	Major Fault
<i>Synchronization message timeout</i>	Flashing b	41	Minor fault
<i>Licence missing</i>	Flashing F	42	Minor fault

Major faults cause the OK relay to open.  
 Minor faults cause an operating error to be displayed.