

FIELD CONTROL

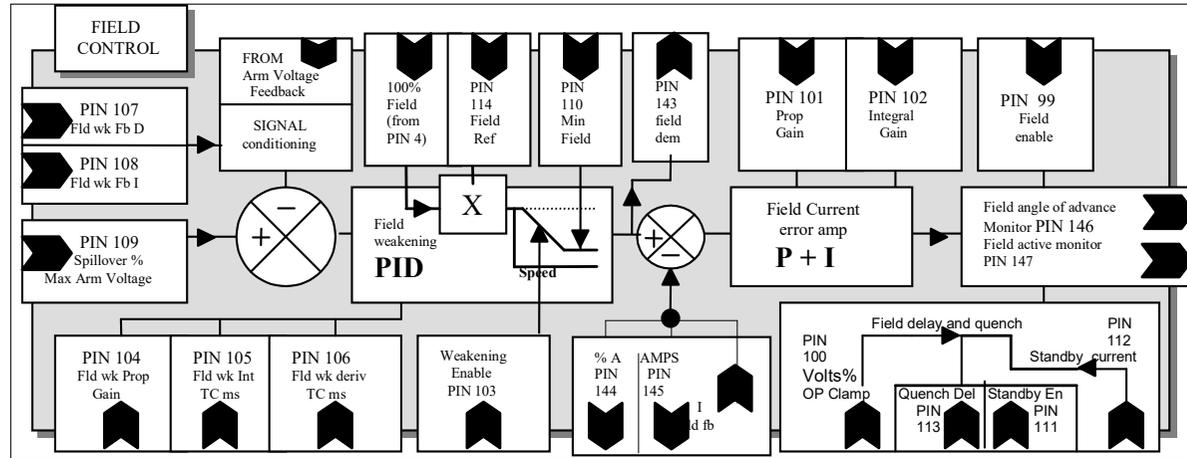

| | | | |
|-----------------------|----------|-------------------------|----------|
| 114)FIELD REFERENCE: | 100.00 | 99)FIELD ENABLE: | ENABLED |
| 100)FIELD VOLTS OP %: | 75.00 | 111)STANDBY FLD ENBL: | ENABLED |
| 101)FIELD PROP GAIN: | 10 | 112)STANDBY FLD CUR: | 30.00 |
| 102)FIELD INT GAIN: | 100 | 113)FLD QUENCH DELAY: | 10.0 |
| 103)FLD WEAK ENABLE: | DISABLED | 143)FIELD DEMAND MON: | 0.00 |
| 104)FLD WK PROP GAIN: | 50 | 144)FIELD CUR % MON: | 0.00 |
| 105)FLD WK INT TC ms: | 4000 | 145)FLD CUR AMPS MON: | 0.00 |
| 106)FLD WK DRV TC ms: | 200 | 146)ANGLE OF ADVANCE: | 0 |
| 107)FLD WK FB DRV ms: | 100 | 147)FIELD ACTIVE MON: | DISABLED |
| 108)FLD WK FB INT ms: | 100 | | |
| 109)SPILLOVER AVF %: | 100.00 | FIELD LOSS WARNING: | LOW |
| 110)MIN FLD CURRENT: | 10.00 | FIELD OVERLOAD WARNING: | LOW |