



CE

Operating instructions
Multifunction displays
for standard analogue signals

UK

AX460

80257643 / 00 01 / 2023



Contents

1	Preliminary note	4
1.1	Symbols and warnings used	4
2	Safety instructions	5
3	Functions and features	5
3.1	Product features:	6
4	Installation.	6
4.1	EMC Guidelines	7
5	General.	7
5.1	Operating mode	7
6	Dimensions and mounting	8
7	Electrical connection.	9
7.1	DC voltage supply	9
7.2	Auxiliary voltage output	10
7.3	Analogue inputs	10
7.4	Control inputs	10
7.5	Reference output	11
7.6	Analogue output (DX2043, DX2053)	12
7.7	Control outputs (DX20x2, DX20x3, DX20x5)	12
7.8	AC voltage supply (DX204x)	13
7.9	IO-Link (DX2045, DX2055)	13
8	Operation / touch screen	14
8.1	Display for parameter setting	14
8.2	Display during operation.	15
8.3	Error messages	16
9	Parameter / menu overview	18
9.1	Overview	18
9.2	General menu.	20
9.3	IN 1 Properties	21
9.4	IN 1 Linearization	24
9.5	IN 1 Totalization	24
9.6	IN 2 Properties	26
9.7	IN 2 Linearization	26
9.8	IN 2 Totalization	26
9.9	Linkage Properties	27
9.10	IO-Link Properties	28
9.11	Preselection Values	29
9.12	Preselection 1 Menu.	29
9.13	Preselection 2 Menu.	32
9.14	Preselection 3 Menu.	33
9.15	Preselection 4 Menu.	34
9.16	Analog Out Menu	35

9.17 Command menu	36
9.18 Display menu	38
10 Linearization	41
11 Technical data	43
12 Maintenance, repair and disposal	45
12.1 Maintenance	45
12.2 Cleaning the housing surface	45
12.3 Repair	45
12.4 Disposal	45



Licences and trademarks

All trademarks and company names used are subject to the copyright of the respective companies.

1 Preliminary note

Technical data, approvals, accessories and further information at www.ifm.com.

1.1 Symbols and warnings used

- ▶ Instructions
- > Reaction, result
- [...] Designation of keys, buttons or indications
- Cross-reference
-  Important note
Non-compliance may result in malfunction or interference.
-  Information
Supplementary note.



WARNING!

Warning of serious personal injury. Death or serious irreversible injuries may result.



CAUTION!

Warning of personal injury.
Slight reversible injuries may result.



NOTE!

Warning of damage to property

2 Safety instructions

- The described unit is a subcomponent to be integrated into a system. The builder of the system is responsible for the safety of the system. It is the system builder's responsibility to perform a risk assessment and to draft a documentation, in accordance with legislation and standard requirements, to be provided to the system operator and the system user. The documentation must contain all information and safety instructions required by the operator, the user and, if applicable, by any service personnel authorised by the builder of the system.
- Read this document before setting up the product and keep it during the entire service life.
- The product must be suitable for the corresponding applications and environmental conditions without any restrictions.
- Only use the product for its intended purpose (→ 3 Functions and features).
- If the operating instructions or the technical data are not adhered to, personal injury and/or damage to property may occur.
- In case of malfunctions of the unit, please contact the manufacturer. Tampering with the unit is not allowed.
- Installation, electrical connection, set-up, programming, configuration, operation and maintenance of the product must be carried out by personnel qualified and authorised for the respective activity.
- Protect units and cables against damage.
- Replace damaged units, since otherwise the technical data and safety will be impaired.

3 Functions and features

This device must only be used in industrial machines and installations. Other uses do not comply with the regulations and are the sole responsibility of the user. The manufacturer is not liable for damage caused by improper use. The device must only be installed in compliance with the instructions and only be used and operated in a perfect technical condition that is in accordance with the technical data. The device is neither suited for explosion-protected areas nor for areas that are excluded in DIN EN 61010-1.

3.1 Product features:

- Multifunction device with operating modes for display of input 1 and input 2 and for linking of input 1 + input 2, input 1 - input 2, input 1 x input 2, input 1 : input 2
- 2 universal 16 bit analogue inputs for -10 ... 10 V / 0 ... 20 mA / 4 ... 20 mA
- Reference output 10 V for potentiometer $1 \geq \text{kohms}$
- 7-segment display with symbols and units
- Parameter setting via clear text and touch screen
- Auxiliary voltage output 24 VDC for sensor supply
- Totalizer for each input
- Linearization with 24 data points per input
- Functions such as tare, averaging, sampling intervals per input
- Standardised 96 x 48 mm housing for panel mounting and protection rating IP65 (front)

4 Installation

The device may only be installed and operated in an environment that is in accordance with the permissible temperature range. Provide sufficient ventilation and avoid direct contact of the unit with hot or aggressive gases or fluids.

Before installation and maintenance works, the unit must be disconnected from all voltage sources. Also ensure that contact with disconnected voltage supply wires is prevented.

Devices that are supplied via AC may only be connected via switches or circuit breakers to the low voltage supply system. This switch must be positioned close to the device and clearly marked as disconnecting device.

Ingoing and outgoing cables for extra-low voltage must be separated from dangerous live cables (SELV circuits) by double and/or reinforced insulation.

The choice of all cables and their insulation must guarantee that they comply with the permissible voltage and temperature range. Moreover, both device and country specific standards are to be observed that apply to the cables with regard to their structure, shape and quality. Please view the technical data for specifications concerning permissible wire cross-sections for the screw terminal connections.

Before set-up, all connections and cables must be checked if they are tightly fitted in the screw terminals. All (even unused) screw terminals must be turned to the right up to the end stop and thereby reliably attached, so that they cannot get loose due to shocks and vibration.

Voltage spikes on the connections of the device are to be limited to the values of overvoltage category II.

4.1 EMC Guidelines

All motrona devices are designed to provide high protection against electromagnetic interference.

Nevertheless you must minimize the influence of electromagnetic noise to the device and all connected cables.

Therefore the following measures are mandatory for a successful installation and operation:

- Use shielded cables for all signal and control input and output lines.
- Cables for digital controls (digital I/O, relay outputs) must not exceed a length of 30 m and are allowed for in building operation only.
- Use shield connection clamps to connect the cable shields properly to earth.
- The wiring of the common ground lines must be star-shaped and common ground must be connected to earth at only one single point.
- The device should be mounted in a metal enclosure with sufficient distance to sources of electromagnetic noise.
- Run signal and control cables apart from power lines and other cables emitting electromagnetic noise.

UK

5 General

The device is designed as panel-mounting display unit for analogue signals (-10 ... 10 V / 0 ... 20 mA / 4 ... 20 mA).

5.1 Operating mode

In general, all functions can be configured in the parameter menu. The device can be operated in the following modes:

- SINGLE:
One-channel operation of input 1.
- DUAL:
Two-channel operation of inputs 1 and 2.
- IN 1 + IN 2:
Two-channel operation of inputs 1 and 2, type of linking: addition.
- IN 1 - IN 2:
Two-channel operation of inputs 1 and 2, type of linking: subtraction.
- IN 1 x IN 2:
Two-channel operation of inputs 1 and 2, type of linking: multiplication.
- IN 1 / IN 2:
Two-channel operation of inputs 1 and 2, type of linking: division.

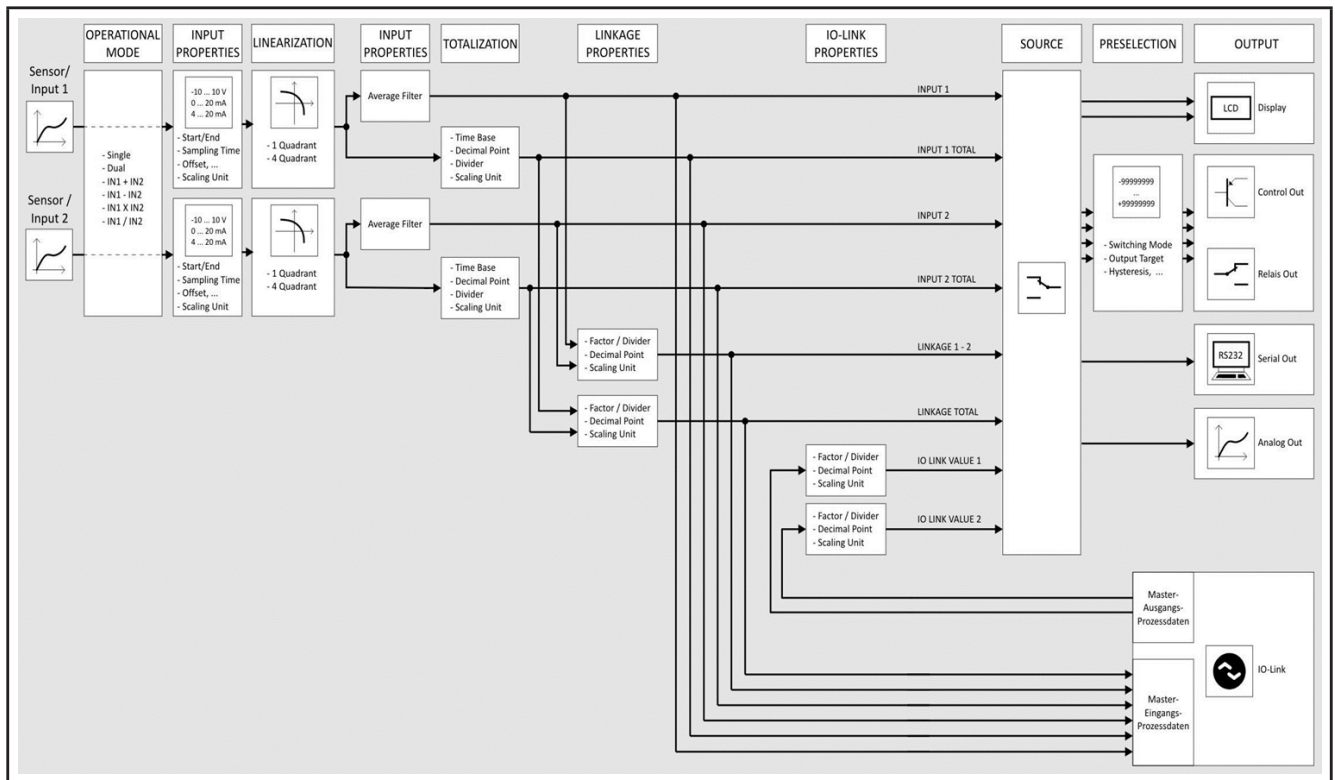

Function diagram

6 Dimensions and mounting

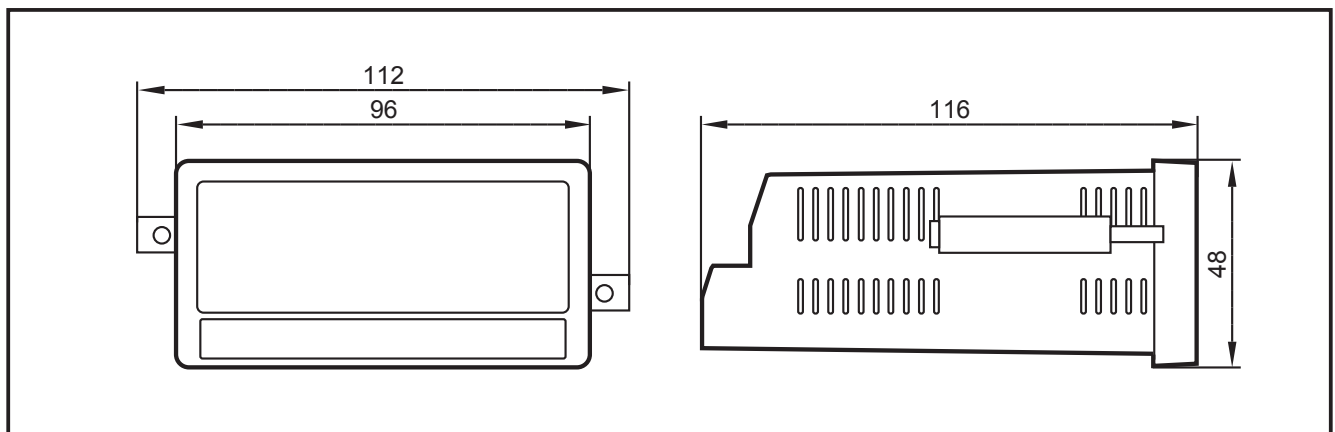

- Make a panel cut-out (91 x 43 mm) and fix the device into the panel with the 2 screws.

7 Electrical connection

NOTE!

- ▶ Connect the IO-Link interface only after connecting the supply voltage.

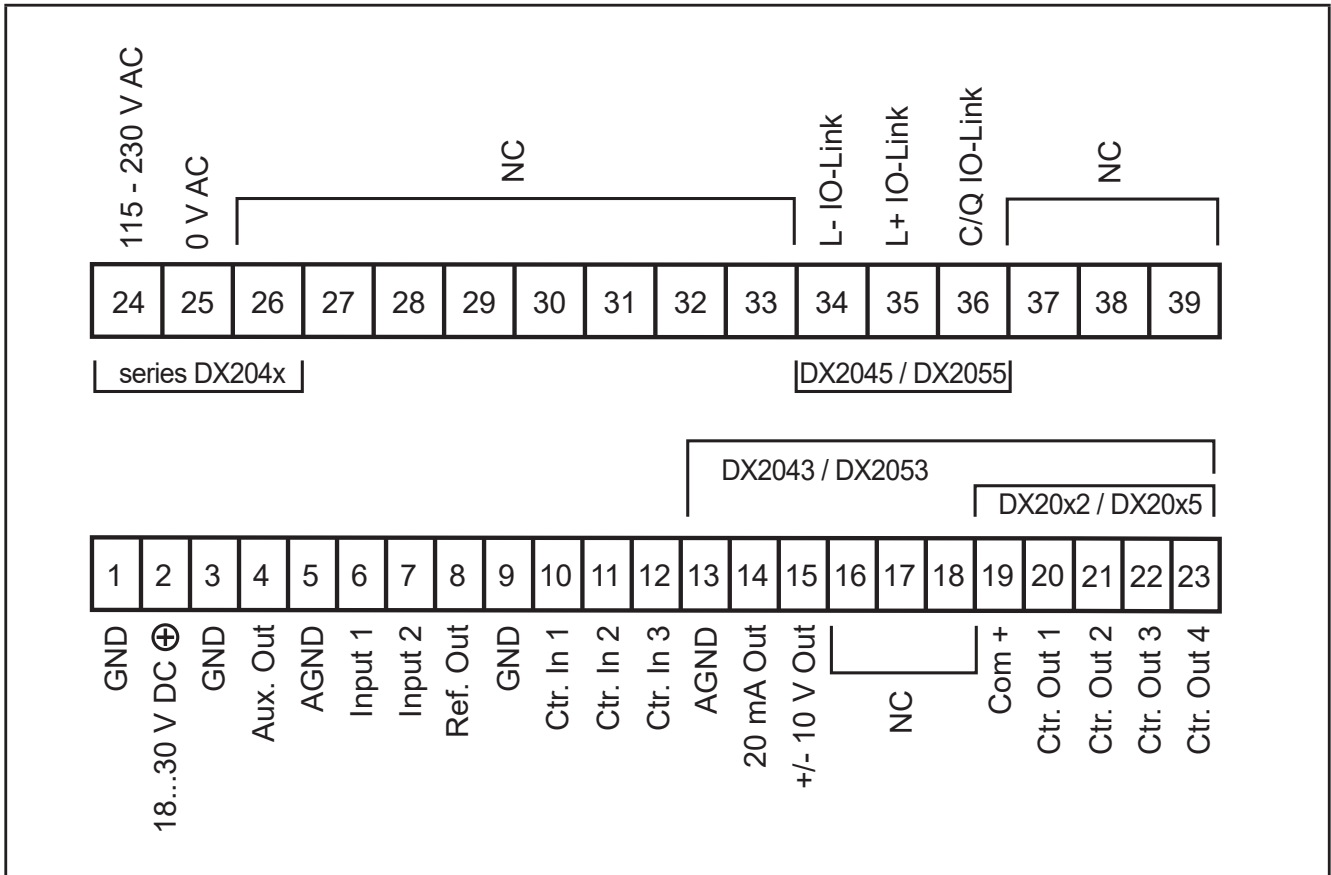

Connections on the rear of the housing



The terminals 16, 17 and 18 must not be used.

7.1 DC voltage supply

The device can be supplied with direct voltage between 18 and 30 V DC via the terminals 1 and 2. The current consumption depends, among other things, on the level of the supply voltage and the setting and is typically at approx. 100 mA plus the sensor current consumed at the auxiliary voltage output.

All GND connections are internally connected with each other.

7.2 Auxiliary voltage output

Auxiliary voltage for sensor supply is provided at terminals 3 and 4.

The output voltage depends on the device supply:

- In case of DC device supply, the output voltage is approx. 1 V less than the supply voltage applied at terminals 1 and 2 and the max. load must not exceed 250 mA.
- In case of AC device supply, the output voltage is 24 VDC ($\pm 15\%$) and the max. load must not exceed 150 mA at temperatures up to 45 °C. At higher temperatures the max. output current is reduced to 80 mA.

7.3 Analogue inputs

On terminal 5, the reference potential (AGND) for the analogue inputs is connected. On terminals 6 and 7, two 16 bit analogue inputs are available. The configuration (voltage input or current input) is set in the IN 1 / IN 2 Properties menus.



The configuration (voltage input or current input) has to be set before connecting the sensor.

Connection of the analogue inputs:

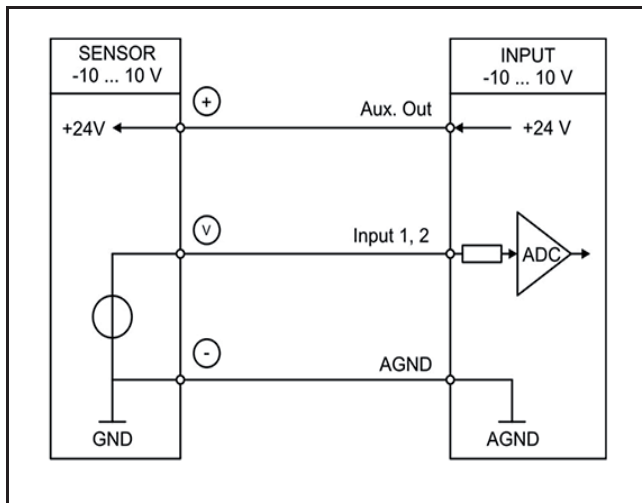

voltage input

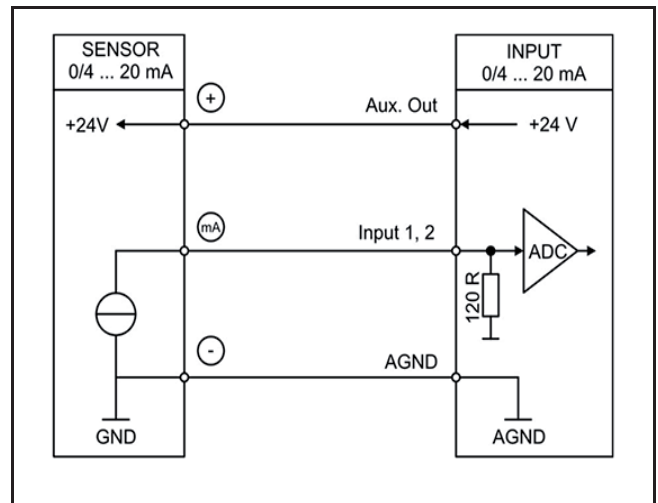

Current input

7.4 Control inputs

On terminals 10, 11 and 12, three control inputs with HTL-PNP characteristic are available.

These inputs can be configured in the COMMAND MENU and are used for functions that can be triggered externally such as resetting the display value, changing the display, locking buttons of the touch screen or releasing the latching of control outputs.

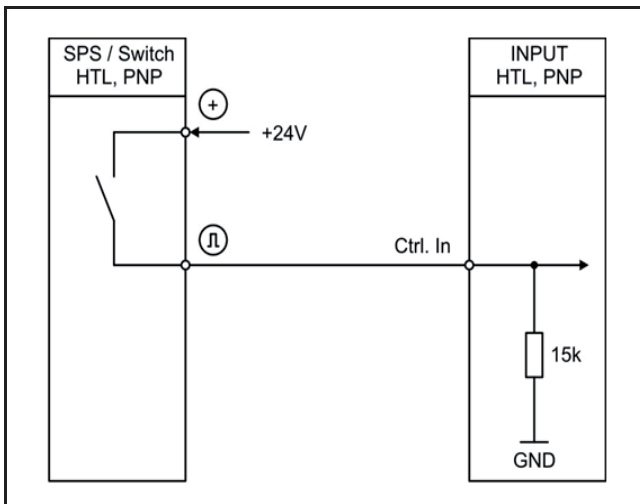

Connection of the control inputs

Open control inputs are generally "LOW".

The input stages are designed for electronic control signals.

Remark on mechanical switching contacts:

If mechanical contacts are to be used as pulse source, a standard, external capacitor of about $10\ \mu\text{F}$ must be connected to the terminals between GND (-) and the corresponding input (+). This damps the maximum input frequency to approx. 20 Hz and contact bouncing is suppressed.

7.5 Reference output

On terminal 8, a 10 V reference output is available. The max. load of this output must not exceed 10 mA. This reference output can, for example, be used to connect a potentiometer.

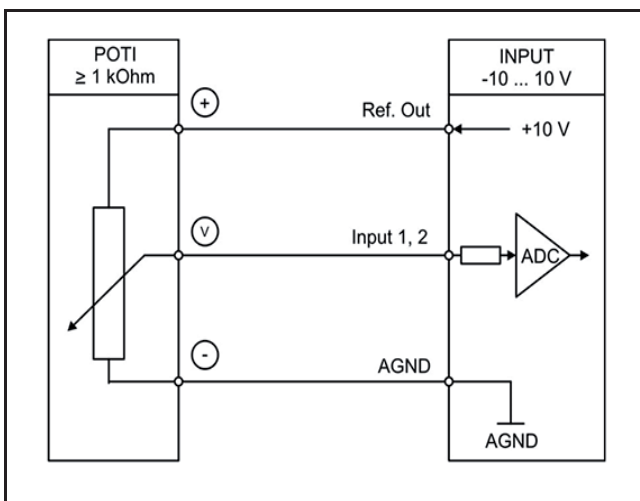

Reference output with potentiometer

7.6 Analogue output (DX2043, DX2053)

On terminals 13 and 14 / 15, a 16 bit analogue output is available.

This output can be configured and scaled in the ANALOG MENU. The following configuration is possible:

- Voltage output: -10 ... +10 V
- Voltage output: 0 ... 20 mA
- Voltage output: 4 ... 20 mA

The analogue output is proportional to the displayed value and refers to the AGND potential.

AGND and device GND are internally connected.



Parallel operation of voltage and current output is not permitted.

7.7 Control outputs (DX20x2, DX20x3, DX20x5)

On terminals 19, 20, 21, 22 and 23, four control outputs are available.

The switching conditions can be set in the PRESELECTION MENU.

The outputs Ctrl. Out 1 – Ctrl. Out 4 are fast PNP outputs with a switching capacity of 5 – 30 V / 200 mA per channel.

The switching voltage is determined by the voltage at terminal 19 (Com+). To switch inductive loads, external damping measures are recommended. The switching status is indicated in the display as C1 – C4 (display with unit and status line).

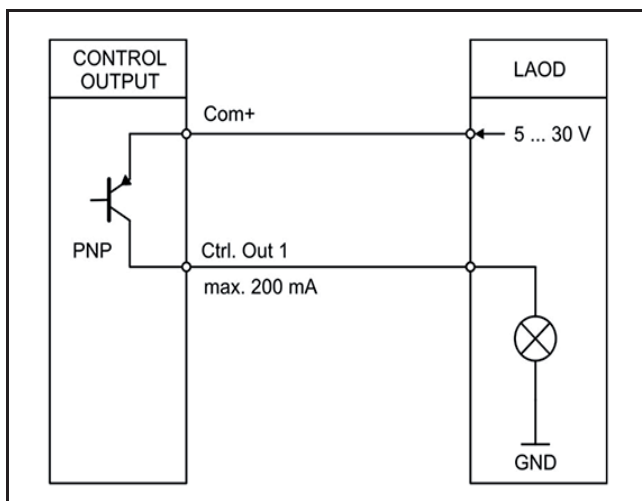

Connection of the control outputs

7.8 AC voltage supply (DX204x)

On terminals 24 and 25, the device can be supplied with an alternating voltage between 115 and 230 V AC. The power consumption depends, among other things, on the level of the supply voltage and the setting and is at approx. 3 VA plus the sensor current consumed at the auxiliary voltage output.

7.9 IO-Link (DX2045, DX2055)

NOTE!

- ▶ Connect the IO-Link interface only after connecting the supply voltage.

UK

Terminals 34, 35 and 36 offer an interface to connect an IO-Link master. The display unit must be connected to a separate voltage supply (AC or DC).

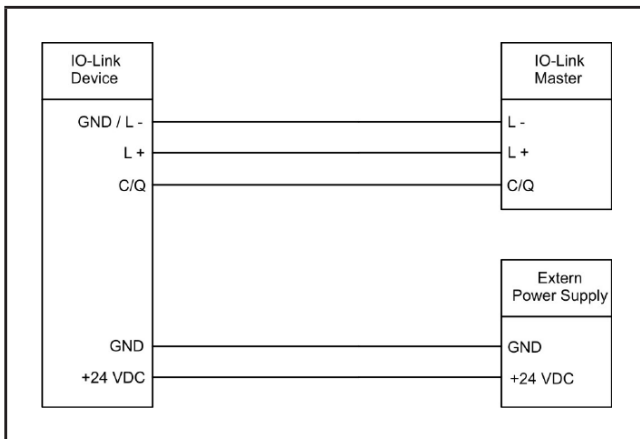

IO-Link interface

The unit can be used in two ways as an IO-Link device:

- Display of 2 output process values:
The IO-Link master cyclically sends 2 output process values. Both values can be additionally configured / scaled in the IO LINK PROPERTIES menu.
- Display for analogue sensors and data transmission of 6 input process values:
The IO-Link master cyclically receives 6 input process values.
The following values are transmitted:
 - Value 1: result of input 1
 - Value 2: result of input 2
 - Value 3: result of the linking of input 1 and input 2
 - Value 4: result of the totalization of input 1
 - Value 5: result of the totalization of input 2
 - Value 6: result of the totalization of the linking of input 1 and input 2

These functions are defined in the IO-Link master.

8 Operation / touch screen

8.1 Display for parameter setting

The individual parameter menus and their parameters are described in a separate chapter (→ 9 Parameter / menu overview).

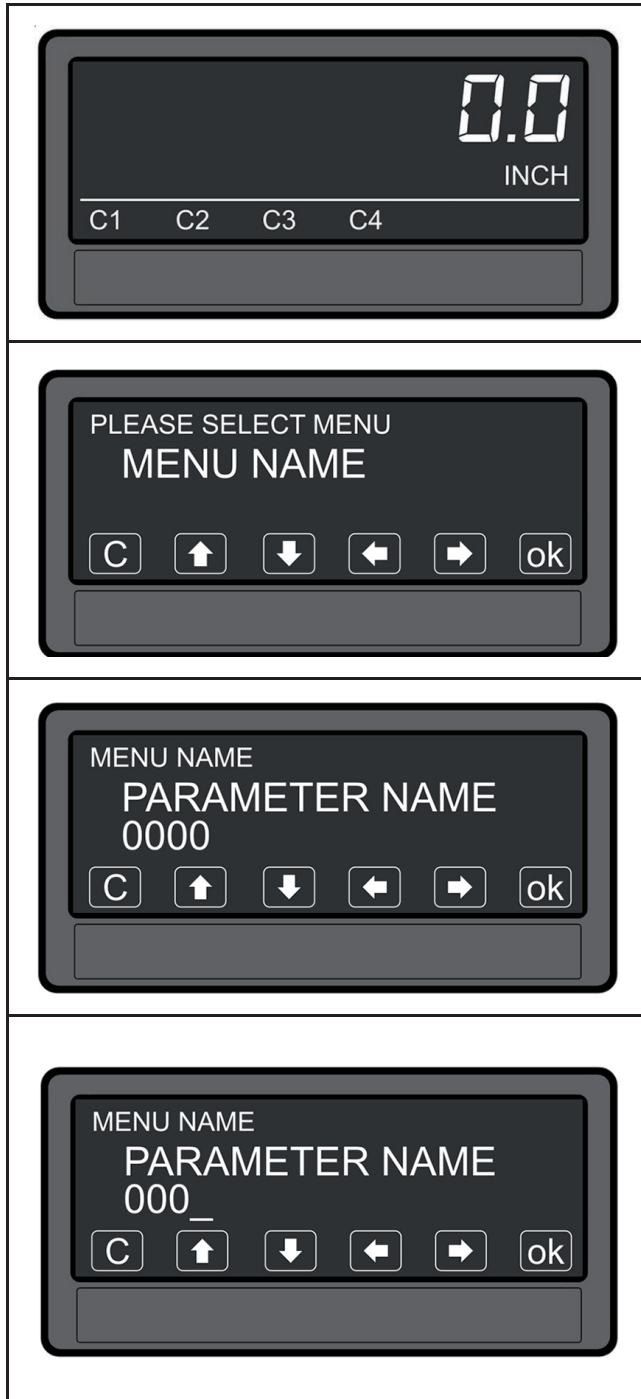

Device parameter setting:

In order to be able to set device parameters, the touch screen must be pressed for 3 seconds.

Select menu:

The required parameter menu can be selected via the arrow keys and confirmed with OK.

To close the menu selection, press [C].

Select parameter:

The required parameter can be selected via the arrow keys and confirmed with OK.

To close the parameter selection, press [C].

Edit parameters:

When the parameter value is flashing, it can be edited via the arrow keys and stored with OK.

To close the editing mode, press [C].

Parameter changes are only active after quitting the menu selection.

8.2 Display during operation

The following displays are available. Depending on the device version and the selected operating mode, only certain visualisations are possible.

The source (input 1, input 2, ...) for the one and two-line display and for the large display is defined in the DISPLAY MENU.

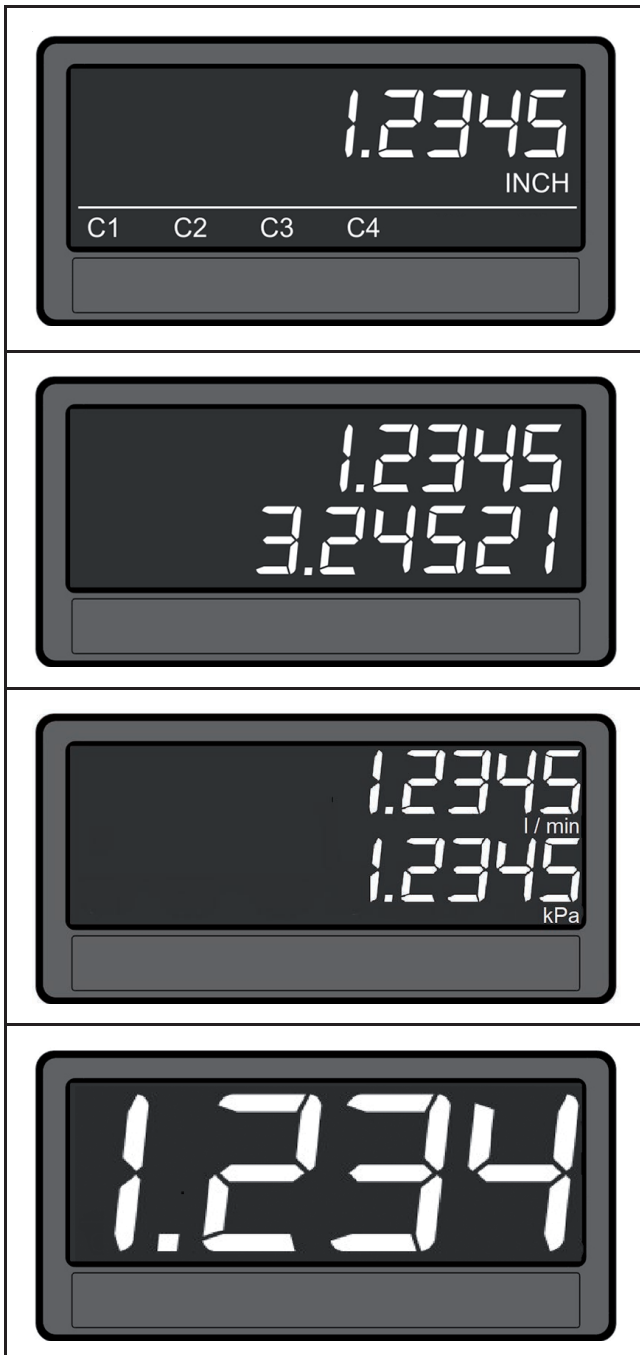

One-line display with unit and status line:

Press the touch screen to access the next display.

Only for DX20x2, DX20x3 and DX20x5.

Two-line display:

Press the touch screen to access the next display.

Two-line display with units:

In order to access the next display, you need to tip the touch screen.

Large display (4-digit):

In order to access the next display, you need to tip the touch screen.

Only if parameter LARGE DISPLAY is activated

UK

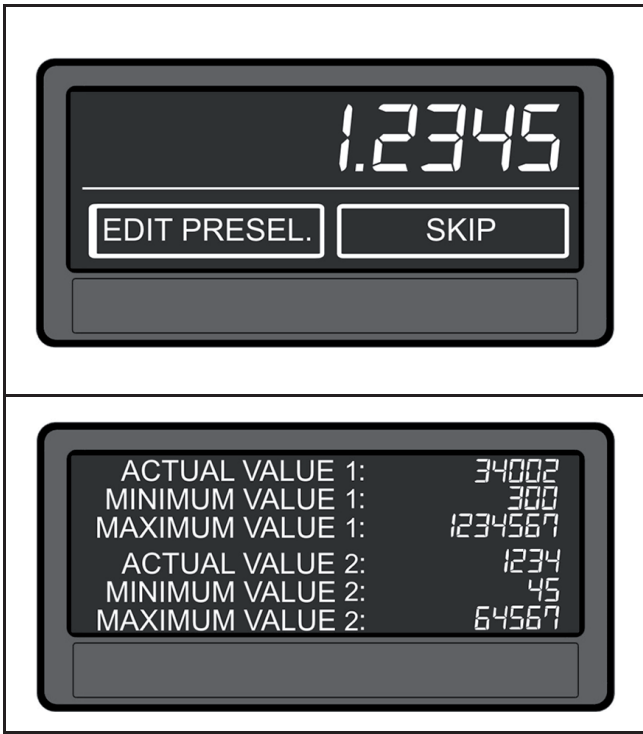

Display with quick-start function to enter the preselection values:

In order to access the next display, you need to tap the top of the touch screen or tap SKIP.

Only for DX20x2, DX20x3 and DX20x5.

Display of the actual / min / max values of input 1 and input 2:

Press the touch screen to access the next display.

8.3 Error messages

Error message in the display	Description
ERROR: MAXIMUM DISPLAY VALUE	Display value of the one-line display is greater than + 99 999 999.
ERROR: MINIMUM DISPLAY VALUE	Display value of the one-line display is smaller than - 99 999 999.
ERROR: MAX. TOP DISPLAY VALUE	Upper display value of the two-line display is greater than + 99 999 999.
ERROR: MIN. TOP DISPLAY VALUE	Upper display value of the two-line display is smaller than - 99 999 999.
ERROR: MAX. DOWN DISPLAY VALUE	Lower display value of the two-line display is greater than + 99 999 999.

Error message in the display	Description
ERROR: MIN. DOWN DISPLAY VALUE	Lower display value of the two-line display is smaller than - 99 999 999.
ERROR: MAX. LARGE DISPLAY VALUE	Display value of the large display is greater than + 9999.
ERROR: MIN. LARGE DISPLAY VALUE	Display value of the large display is smaller than - 9999.

UK



The described error messages are automatically reset as soon as the corresponding display value is again in the range that can be displayed.

9 Parameter / menu overview

9.1 Overview

This section gives an overview of the individual menus and their parameters. The menu name is always in bold characters. The parameters belonging to the menu are arranged directly under the menu name. Default values are greyed out. Depending on the device version and the selected operating mode only certain menus are displayed.

The following menu structure is valid for software version 06C or higher.

Menu / parameter	Menu / parameter
GENERAL MENU	IN 1 TOTALIZATION
OPERATIONAL MODE	TIME BASE
PIN PRESELECTION	DIVIDER
PIN PARAMETER	DECIMAL POINT
BACK UP MEMORY	SCALE UNITS
FACTORY SETTINGS	
	IN 2 PROPERTIES
IN 1 PROPERTIES	CONFIGURATION
CONFIGURATION	START VALUE
START VALUE	END VALUE
END VALUE	DECIMAL POINT
DECIMAL POINT	SCALE UNITS
SCALE UNITS	SAMPLING TIME (S)
SAMPLING TIME (S)	AVERAGE FILTER
AVERAGE FILTER	OFFSET
OFFSET	LINEARIZATION
LINEARIZATION	TOTALIZATION
TOTALIZATION	
	IN 2 LINEARIZATION
IN 1 LINEARIZATION	P1(X)
P1(X)	P1(Y)
P1(Y)	P2(X)
P2(X)	P2(Y)
P2(Y)	...
...	P24(X)
P24(X)	P24(Y)
P24(Y)	

Menu / parameter	Menu / parameter
IN 2 TOTALIZATION	PRESELECTION 1 MENU
TIME BASE	SOURCE 1
DIVIDER	MODE 1
DECIMAL POINT	HYSTERESIS 1
SCALE UNITS	PULSE TIME 1 (S)
	OUTPUT TARGET 1
LINKAGE PROPERTIES	OUTPUT POLARITY 1
FACTOR	OUTPUT LOCK 1
DIVIDER	START UP DELAY 1 (S)
ADDITIVE VALUE	EVENT COLOR 1
DECIMAL POINT	
SCALE UNITS	PRESELECTION 2 MENU
	SOURCE 2
IO LINK PROPERTIES	MODE 2
IN1 FACTOR	HYSTERESIS 2
IN1 DIVIDER	PULSE TIME 2 (S)
IN1 ADDITIVE VALUE	OUTPUT TARGET 2
IN1 DECIMAL POINT	OUTPUT POLARITY 2
IN1 SCALE UNITS	OUTPUT LOCK 2
IN2 FACTOR	START UP DELAY 2 (S)
IN2 DIVIDER	EVENT COLOR 2
IN2 ADDITIVE VALUE	
IN2 DECIMAL POINT	PRESELECTION 3 MENU
IN2 SCALE UNITS	SOURCE 3
	MODE 3
PRESELECTION VALUES	HYSTERESIS 3
PRESELECTION 1	PULSE TIME 3 (S)
PRESELECTION 2	OUTPUT TARGET 3
PRESELECTION 3	OUTPUT POLARITY 3
PRESELECTION 4	OUTPUT LOCK 3
	START UP DELAY 3 (S)
	EVENT COLOR 3

Menu / parameter	Menu / parameter
PRESELECTION 4 MENU	COMMAND MENU
SOURCE 4	INPUT 1 ACTION
MODE 4	INPUT 1 CONFIG
HYSTERESIS 4	INPUT 2 ACTION
PULSE TIME 4 (S)	INPUT 2 CONFIG
OUTPUT TARGET 4	INPUT 3 ACTION
OUTPUT POLARITY 4	INPUT 3 CONFIG
OUTPUT LOCK 4	
START UP DELAY 4 (S)	DISPLAY MENU
EVENT COLOR 4	START DISPLAY
	SOURCE SINGLE
ANALOG OUT MENU	SOURCE DUAL TOP
ANALOG SOURCE	SOURCE DUAL DOWN
ANALOG FORMAT	LARGE DISPLAY
ANALOG START	SOURCE LARGE
ANALOG END	COLOR
ANALOG GAIN (%)	BRIGHTNESS (%)
ANALOG OFFSET (%)	CONTRAST
	SCREEN SAVER (S)
	UP-DATE-TIME (S)
	FONT

9.2 General menu

OPERATIONAL MODE	
This parameter defines which measuring function (operating mode) the device is supposed to fulfil.	
SINGLE	One-channel operation (only input 1)
DUAL	Two-channel operation (input 1 and 2 separately)
IN 1 + IN 2	Two-channel operation of inputs 1 and 2, type of linking: addition.
IN 1 – IN 2	Two-channel operation of inputs 1 and 2, type of linking: subtraction.
IN 1 x IN 2	Two-channel operation of inputs 1 and 2, type of linking: multiplication.
IN 1 / IN 2	Two-channel operation of inputs 1 and 2, type of linking: division.
PIN PRESELECTION	
This parameter defines the PIN code for locking the quick-start function to enter the preselection values in the PRESELECTION VALUES menu (emergency PIN: 6079). Locking the quick start is only useful if all parameters are locked.	

0000	Access not locked
...	
9999	Access after entering the PIN code 9999
PIN PARAMETER	
This parameter defines the PIN code for the locked access for all parameters (emergency PIN: 6079).	
0000	Access not locked
...	
9999	Parameter setting of the device is only possible after entering the PIN code.
BACK UP MEMORY	
NO	No backup in case of a power failure.
YES	In case of a power failure the device stores the actual value. Only for totalizer.
FACTORY SETTINGS	
NO	The factory settings are not loaded.
YES	The factory settings are loaded (default values highlighted in grey).

UK

9.3 IN 1 Properties

In this menu the parameters for output 1 are defined.

CONFIGURATION	
This parameter defines the configuration of input 1.	
-10 ... +10 V	Voltage input -10 ... 10 V
0 ... 20 mA	Current input 0 ... 20 mA
4 ... 20 mA	Current input 4 ... 20 mA
START VALUE	
This parameter defines the display value for an input signal of 0 V, 0 mA or 4 mA. Signals between START VALUE and END VALUE behave proportionally.	
-99999	Lowest value
0	Default value
99999	Highest value
END VALUE	
This parameter defines the display value for an input signal of 10 V or 20 mA. Signals between START VALUE and END VALUE behave proportionally.	
-99999	Lowest value
10000	Default value
99999	Highest value

DECIMAL POINT

This setting defines the position of the decimal point.

NO	No decimal point
0000000.0	Decimal point at the specified spot
000000.00	Decimal point at the specified spot
00000.000	Decimal point at the specified spot
0000.0000	Decimal point at the specified spot
000.00000	Decimal point at the specified spot
00.000000	Decimal point at the specified spot
0.0000000	Decimal point at the specified spot

SCALE UNITS

This parameter defines which unit is indicated in the display. It does not influence the display value. The decimal point for decimal places is set with the DECIMAL POINT parameter.

V	Default
mV	
A	
mA	
km/h	
mph	
feet/min	
inch/min	
g	
kg	
oz	
W	
kW	
VA	
mm	
cm	
m	
inches	
feet	
C	
F	
K	
1/sec	
1/min	

1/h																																																																																																	
gal/min																																																																																																	
Pa																																																																																																	
kPa																																																																																																	
%																																																																																																	
Edit Unit	<p>With this parameter, a customer-specific unit with up to 16 digits can be edited.</p> <p>Open the "Edit Unit" menu with the [OK] button. Use the arrow keys to change the unit. Keep the arrow key pressed for fast scrolling. Save with [OK]. Quit the "Edit Unit" menu with [C].</p> <table border="1"> <tr> <td></td><td>!</td><td>"</td><td>#</td><td>\$</td><td>%</td><td>&</td><td>'</td><td>(</td><td>)</td><td>*</td><td>+</td><td>,</td><td>-</td><td>.</td><td>/</td> </tr> <tr> <td>0</td><td>1</td><td>2</td><td>3</td><td>4</td><td>5</td><td>6</td><td>7</td><td>8</td><td>9</td><td>:</td><td>;</td><td><</td><td>=</td><td>></td><td>?</td> </tr> <tr> <td>@</td><td>A</td><td>B</td><td>C</td><td>D</td><td>E</td><td>F</td><td>G</td><td>H</td><td>I</td><td>J</td><td>K</td><td>L</td><td>M</td><td>N</td><td>O</td> </tr> <tr> <td>P</td><td>Q</td><td>R</td><td>S</td><td>T</td><td>U</td><td>V</td><td>W</td><td>X</td><td>Y</td><td>Z</td><td>[</td><td>\</td><td>]</td><td>^</td><td>_</td> </tr> <tr> <td>`</td><td>a</td><td>b</td><td>c</td><td>d</td><td>e</td><td>f</td><td>g</td><td>h</td><td>i</td><td>j</td><td>k</td><td>l</td><td>m</td><td>n</td><td>o</td> </tr> <tr> <td>p</td><td>q</td><td>r</td><td>s</td><td>t</td><td>u</td><td>v</td><td>w</td><td>x</td><td>y</td><td>z</td><td>{</td><td> </td><td>}</td><td>~</td><td></td> </tr> </table>		!	"	#	\$	%	&	'	()	*	+	,	-	.	/	0	1	2	3	4	5	6	7	8	9	:	;	<	=	>	?	@	A	B	C	D	E	F	G	H	I	J	K	L	M	N	O	P	Q	R	S	T	U	V	W	X	Y	Z	[\]	^	_	`	a	b	c	d	e	f	g	h	i	j	k	l	m	n	o	p	q	r	s	t	u	v	w	x	y	z	{		}	~	
	!	"	#	\$	%	&	'	()	*	+	,	-	.	/																																																																																		
0	1	2	3	4	5	6	7	8	9	:	;	<	=	>	?																																																																																		
@	A	B	C	D	E	F	G	H	I	J	K	L	M	N	O																																																																																		
P	Q	R	S	T	U	V	W	X	Y	Z	[\]	^	_																																																																																		
`	a	b	c	d	e	f	g	h	i	j	k	l	m	n	o																																																																																		
p	q	r	s	t	u	v	w	x	y	z	{		}	~																																																																																			

SAMPLING TIME (S)

The set value corresponds to the sampling interval. This interval defines the interval in seconds between the samples of the analogue signal. This parameter has a direct influence on the response time of the device.

0,001	Lowest value
0.01	Default value
60,000	Highest value

AVERAGE FILTER

Optional averaging to prevent display fluctuations.

OFF	No averaging
CYCLE FILTER 2	Free-flowing averaging with 2 cycles
CYCLE FILTER 4	Free-flowing averaging with 4 cycles
CYCLE FILTER 8	Free-flowing averaging with 8 cycles
CYCLE FILTER 16	Free-flowing averaging with 16 cycles

OFFSET

With this parameter, the zero point shift / tare of the input is set.

-99,999	Lowest value
0	Default value
+99,999	Highest value

LINEARIZATION	
This parameter defines the linearization function (→). The linearization points are set in the IN 1 / IN 2 LINEARIZATION menu.	
OFF	No linearization
1 QUADRANT	Linearization in the 1st quadrant
4 QUADRANT	Linearization in all 4 quadrants
TOTALIZATION	
This parameter activates the totalization function. Settings are made in the IN 1 / IN 2 TOTALIZATION menu. The totalization depends on the selected operating mode (→ 9.5 IN 1 Totalization).	
NO	No totalization
YES	Totalization active

9.4 IN 1 Linearization

In this menu, the linearization points for input 1 are defined. This menu is only displayed if the corresponding linearization is selected in the IN 1 PROPERTIES menu (→).

P1(X) ... P24(X)	
X coordinate of the linearization point	
This is the display value which the device generates without linearization depending on the input signal.	
-99999999	Lowest value
0	Default value
+99999999	Highest value
P1(Y) ... P24(Y)	
Y coordinate of the linearization point	
This is the display value which the device is to generate instead of the X coordinate. For example, P2(X) is replaced by P2(Y).	
-99999999	Lowest value
0	Default value
+99999999	Highest value

9.5 IN 1 Totalization

In this menu the parameters for the totalization are defined. This menu is only displayed if the totalization has been activated in the IN 1 PROPERTIES menu. The totalizer depends on the selected operating mode (see table below).

Operating mode	Totalizer		
	INPUT 1 TOTAL	INPUT 2 TOTAL	LINKAGE TOTAL
SINGLE	active	→ 0	→ 0
DUAL	active	active	→ 0

Operating mode	Totalizer		
	INPUT 1 TOTAL	INPUT 2 TOTAL	LINKAGE TOTAL
IN 1 + IN 2	active	active	Total 1 + Total 2
IN 1 - IN 2	active	active	Total 1 - Total 2
IN 1 x IN 2	active	active	→ 0
IN 1 / IN 2	active	active	→ 0

TIME BASE

This parameter defines the time base for the totalization. It indicates the time interval for the detection of the measured values.

SECONDS	The current value is added to INPUT 1 TOTAL every second
MINUTES	The current value is added to INPUT 1 TOTAL every minute
HOURS	The current value is added to INPUT 1 TOTAL every hour
COMMAND	The current value of input 1 is added to INPUT 1 TOTAL by means of the command (ADD TO TOTAL 1) via the operation function of a control input (→ 9.17 Command menu).

DIVIDER

This parameter defines the divisor for the totalization.

1	No division
10	Result of the totalization is divided by 10.
100	Result of the totalization is divided by 100.
1000	Result of the totalization is divided by 1000.

DECIMAL POINT

This setting defines the position of the decimal point.

NO	No decimal point
0000000.0	Decimal point at the specified spot
000000.00	Decimal point at the specified spot
00000.000	Decimal point at the specified spot
0000.0000	Decimal point at the specified spot
000.00000	Decimal point at the specified spot
00.000000	Decimal point at the specified spot
0.0000000	Decimal point at the specified spot

SCALE UNITS

Configuration of the indicated unit (→ 9.3 IN 1 Properties)

9.6 IN 2 Properties

In this menu the parameters for output 2 are defined.

CONFIGURATION Configuration of input 2 (→ 9.3 IN 1 Properties)
START VALUE Display value of input 2 for an input signal of 0 V, 0 mA or 4 mA (→ 9.3 IN 1 Properties)
END VALUE Display value of input 2 for an input signal of 10 V or 20 mA (→ 9.3 IN 1 Properties)
DECIMAL POINT Setting of the decimal point (→ 9.3 IN 1 Properties)
SCALE UNITS Unit indicated on the display (→ 9.3 IN 1 Properties)
SAMPLING TIME (S) Sampling interval of input 2 (→ 9.3 IN 1 Properties)
AVERAGE FILTER Optional averaging (→ 9.3 IN 1 Properties)
OFFSET Zero point shift / tare (→ 9.3 IN 1 Properties)
LINEARIZATION Linearization function (→ 9.3 IN 1 Properties)
TOTALIZATION Totalization function (→ 9.3 IN 1 Properties)

9.7 IN 2 Linearization

In this menu the linearization points for output 2 are defined.

P1(X) ... P24(X) X coordinate of the linearization point (→ 9.4 IN 1 Linearization)
P1(Y) ... P24(Y) Y coordinate of the linearization point (→ 9.4 IN 1 Linearization)

9.8 IN 2 Totalization

In this menu the parameters for the totalization of input 2 are defined.

TIME BASE Time base for the totalization (→ 9.5 IN 1 Totalization)
DIVIDER Divisor for the totalization (→ 9.5 IN 1 Totalization)

DECIMAL POINT

Position of the decimal point (→ 9.5 IN 1 Totalization)

SCALE UNITS

Unit indicated on the display (→ 9.5 IN 1 Totalization)

9.9 Linkage Properties

In this menu the parameters for the linked operating mode are defined. This menu is only displayed if an operating mode with linking (e.g. IN 1 – IN 2) has been selected in the GENERAL MENU. For use of a linked operating mode the parameters in the IN 1 PROPERTIES and IN 2 PROPERTIES menus have to be set first. The result of the linking can be scaled with the following parameters.

UK

FACTOR

This parameter defines the factor with which the result of the linking is offset.

-99999999	Lowest value
1	Default value
99999999	Highest value

DIVIDER

This parameter defines the divisor with which the result of the linking is offset.

-99999999	Lowest value
1	Default value
99999999	Highest value

ADDITIVE VALUE

This parameter defines a constant that is added to the result of the linking.

-99999999	Lowest value
0	Default value
99999999	Highest value

DECIMAL POINT

This setting defines the position of the decimal point (→ 9.5 IN 1 Totalization).

SCALE UNITS

Configuration of the indicated unit (→ 9.3 IN 1 Properties)

9.10 IO-Link Properties

In this menu, the parameters for the display of both output process data values can be defined

This function is only available for the devices DX2045 and DX2055.

IN1 FACTOR	
This parameter defines the factor with which the received value 1 is offset.	
-99999999	Lowest value
1	Default value
99999999	Highest value
IN1 DIVIDER	
This parameter defines the divisor with which the received value 1 is offset.	
-99999999	Lowest value
1	Default value
99999999	Highest value
IN1 ADDITIVE VALUE	
This parameter defines a constant that is added to the received value.	
-99999999	Lowest value
0	Default value
99999999	Highest value
IN1 DECIMAL POINT	
This setting defines the position of the decimal point for value 1 (→ 9.5 IN 1 Totalization).	
IN1 SCALE UNITS	
Configuration of the unit that the display indicates for value 1 (→ 9.3 IN 1 Properties)	
IN2 FACTOR	
This parameter defines the factor with which the received value 2 is offset (see IOL IN1 FACTOR).	
IN2 DIVIDER	
This parameter defines the divisor with which the received value 2 is offset (see IOL IN1 DIVIDER).	
IN2 ADDITIVE VALUE	
This parameter defines a constant that is added to the received value 2 (see IOL IN1 ADDITIVE VALUE).	
IN2 DECIMAL POINT	
This setting defines the position of the decimal point for value 1 (→ 9.5 IN 1 Totalization).	
IN2 SCALE UNITS	
Configuration of the unit that the display indicates for value 1 (→ 9.3 IN 1 Properties)	

9.11 Preselection Values

In this menu, the preselection values and switching values are set. The preselection values / switch points always refer to the parameter SOURCE selected in the PRESELECTION x MENU.

This function is only available for the devices DX20x2, DX20x3 and DX20x5.

PRESELECTION 1	
Preselection / switch point 1	
-99999999	Lowest preselection value
1000	Default value
+99999999	Highest preselection value
PRESELECTION 2	
Preselection / switch point 2	
-99999999	Lowest preselection value
2000	Default value
+99999999	Highest preselection value
PRESELECTION 3	
Preselection / switch point 3	
-99999999	Lowest preselection value
3000	Default value
+99999999	Highest preselection value
PRESELECTION 4	
Preselection / switch point 4	
-99999999	Lowest preselection value
4000	Default value
+99999999	Highest preselection value

UK

9.12 Preselection 1 Menu

In this menu the parameters for the source, the switching conditions and further definitions for the preselection value / switching point 1 are set.

This function is only available for the devices DX20x2, DX20x3 and DX20x5.

SOURCE 1	
This parameter defines the source for preselection 1.	
INPUT 1	Source is input 1
INPUT 2	Source is input 2
LINKAGE 1 – 2	The source is the result of the linking of input 1 and input 2
INPUT 1 TOTAL	Source is input 1 with totalization

INPUT 2 TOTAL	Source is input 2 with totalization
LINKAGE TOTAL	The source is the result of the linking of input 1 and input 2 with totalization
IO LINK VALUE 1	The PDout value 1 sent by the IO-Link master is the source for preselection
IO LINK VALUE 2	The PDout value 2 sent by the IO-Link master is the source for preselection
MINIMUM VALUE 1	Source is input 1
MAXIMUM VALUE 1	Source is input 1
MINIMUM VALUE 2	Source is input 2
MAXIMUM VALUE 2	Source is input 2
MODE 1	
Switching condition for preselection 1. Output / display switch according to the following conditions:	
$ \text{RESULT} \geq \text{PRES} $	The result of the display value is greater than or equal to the result of preselection 1 With hysteresis 1 not equal to 0, the following switching condition results: Display value \geq preselection 1 \rightarrow ON Display value $<$ preselection 1 - hysteresis 1 \rightarrow OFF
$ \text{RESULT} \leq \text{PRES} $	The result of display value is smaller or equal to the result of Preselection 1 (start-up delay recommended) With hysteresis 1 not equal to 0 the following switching condition results: Display value \leq preselection 1 \rightarrow ON Display value $>$ preselection 1 + hysteresis 1 \rightarrow OFF
$ \text{RESULT} = \text{PRES} $	The result of the display value is equal to the result of preselection 1. In combination with hysteresis, a frequency band (preselection \pm 1/2 hysteresis) can be defined and monitored. With hysteresis 1 not equal to 0 the following switching condition results: Display value $>$ preselection 1 + 1/2 hysteresis 1 \rightarrow OFF Display value $<$ preselection 1 - 1/2 hysteresis 1 \rightarrow OFF
$\text{RESULT} \geq \text{PRES}$	If the display value is greater than or equal to preselection 1, e.g. overspeed With hysteresis 1 not equal to 0 the following switching condition results: Display value \geq preselection 1 \rightarrow ON Display value $<$ preselection 1 - hysteresis 1 \rightarrow OFF
$\text{RESULT} \leq \text{PRES}$	If the display value is smaller than or equal to preselection 1, e.g. underspeed (start-up delay recommended) With hysteresis 1 not equal to 0 the following switching condition results: Display value \leq preselection 1 \rightarrow ON Display value $>$ preselection 1 + hysteresis 1 \rightarrow OFF

RESULT=PRE5	Display value equal to preselection 1. In combination with hysteresis 1 a frequency band (preselection +/- 1/2 hysteresis) can be defined and monitored. With hysteresis 1 not equal to 0 the following switching condition results: Display value > preselection 1 + 1/2 hysteresis 1 → OFF Display value < preselection 1 - 1/2 hysteresis 1 → OFF
RES≥PRES-TRAIL	Tracking preset 1: Display value greater or equal to preselection 2 – preselection 1 Preselection 1 is the tracking preset of preselection 2.
HYSTERESIS 1 Hysteresis to define the switch-off point for the switching condition of preselection 1	
0	No switching hysteresis
...	
99999	Switching hysteresis of 99999
PULSE TIME 1 (S) Duration of the fleeting pulse (in seconds) for the switching condition of preselection 1	
0,000	No fleeting pulse (static signal)
...	
60,000	Pulse duration of 60 seconds
OUTPUT TARGET 1 Assignment of an output for the switching condition of preselection 1. If several switching conditions are assigned to one single output, this output is active as soon as one of the switching conditions is met.	
NO	No attribution
CTRL OUT 1	Assignment of the switching condition to Ctrl. Out 1
CTRL OUT 2	Assignment of the switching condition to Ctrl. Out 2
CTRL OUT 3	Assignment of the switching condition to Ctrl. Out 3
CTRL OUT 4	Assignment of the switching condition to Ctrl. Out 4
OUTPUT POLARITY 1 Start-up delay for the switching condition of preselection 1	
ACTIVE HIGH	Active "HIGH"
ACTIVE LOW	Active "LOW"
OUTPUT LOCK 1 Start-up delay for the switching condition of preselection 1	
NO	No latching
YES	Latching

START UP DELAY 1 (S)	
Start-up delay for the switching condition of preselection 1. Time window until the monitoring function has been activated. This setting only applies for the switching conditions !RESULT!≤!PRES! and RESULT≤PRES. (Start-up delays 3 and 4 are set automatically.)	
0,000	No start-up delay
...	
60,000	Start-up delay in seconds
EVENT COLOR 1	
Event-dependent colour change of the display for the switching condition of preselection 1. Event Color 1 is of lowest priority. Event Color 2 ... 4 can overwrite this colour change.	
NO CHANGE	No colour change
CHANGE TO RED	Colour changes to red
CHANGE TO GREEN	Colour changes to green
CHANGE TO YELLOW	Colour changes to yellow

9.13 Preselection 2 Menu

SOURCE 2	
Source for preselection 2 (→ 9.12 Preselection 1 Menu)	
MODE 2	
Switching condition for preselection 2, (→ 9.12 Preselection 1 Menu) (except tracking preset)	
	see Preselection 1 Menu
RES≥PRES-TRAIL	Tracking preset 2: Display value greater than or equal to preselection 1 – preselection 2 Preselection 2 is the tracking preset of preselection 1.
HYSTERESIS 2	
Switching hysteresis for the switching condition of preselection 2 (→ 9.12 Preselection 1 Menu)	
PULSE TIME 2 (S)	
Duration of the fleeting pulse for the switching condition of preselection 2 (→ 9.12 Preselection 1 Menu)	
OUTPUT TARGET 2	
Assignment of an output for the switching condition of preselection 2 (→ 9.12 Preselection 1 Menu) (except default value)	
	see Preselection 1 Menu
CTRL OUT 2	Assignment of the switching condition to Ctrl. Out 2
OUTPUT POLARITY 2	
Switching status for the switching condition of preselection 2 (→ 9.12 Preselection 1 Menu)	
OUTPUT LOCK 2	
Latching for the switching condition of preselection 2 (→ 9.12 Preselection 1 Menu)	

START UP DELAY 2 (S)

Start-up delay for the switching condition of preselection 2 (→ 9.12 Preselection 1 Menu)
(Start-up delays 3 and 4 are set automatically.)

EVENT COLOR 2

Event-dependent colour change of the display for the switching condition of preselection 2, see Preselection 1 Menu

9.14 Preselection 3 Menu**SOURCE 3**

Source for preselection 3 (→ 9.12 Preselection 1 Menu)

MODE 3

Switching condition for preselection 3, (→ 9.12 Preselection 1 Menu) (except tracking preset)

see Preselection 1 Menu

RES≥PRES-TRAIL

Tracking preset 3:
Display value greater or equal to preselection 4 – preselection 3
Preselection 3 is the tracking preset of preselection 4.

HYSTERESIS 3

Switching hysteresis for the switching condition of preselection 3 (→ 9.12 Preselection 1 Menu)

PULSE TIME 3 (S)

Duration of the fleeting pulse for the switching condition of preselection 3 (→ 9.12 Preselection 1 Menu)

OUTPUT TARGET 3

Assignment of an output for the switching condition of preselection 3 (→ 9.12 Preselection 1 Menu)
(except default value)

see Preselection 1 Menu

CTRL OUT 3

Assignment of the switching condition to Ctrl. Out 3

OUTPUT POLARITY 3

Switching status for the switching condition of preselection 3 (→ 9.12 Preselection 1 Menu)

OUTPUT LOCK 3

Latching for the switching condition of preselection 3 (→ 9.12 Preselection 1 Menu)

START UP DELAY 3 (S)

Start-up delay for the switching condition of preselection 3. This setting only applies for the switching conditions $|\text{RESULT}| \leq |\text{PRES}|$ und $\text{RESULT} \leq \text{PRES}$.
(Start-up delays 1 and 2 are time-dependent.)

OFF

No start-up delay

AUTO

Automatic start-up delay until the preselection value / switch point is exceeded for the first time.

EVENT COLOR 3

Event-dependent colour change of the display for the switching condition of preselection 3, see Preselection 1 Menu

9.15 Preselection 4 Menu

SOURCE 4	
Source for preselection 4 (→ 9.12 Preselection 1 Menu)	
MODE 4	
Switching condition for preselection 4, (→ 9.12 Preselection 1 Menu) (except tracking preset)	
	see Preselection 1 Menu
RES≥PRES-TRAIL	Tracking preset 4: Display value greater or equal to preselection 3 – preselection 4 Preselection 4 is the tracking preset of preselection 3.
HYSTERESIS 4	
Switching hysteresis for the switching condition of preselection 4 (→ 9.12 Preselection 1 Menu)	
PULSE TIME 4 (S)	
Duration of the fleeting pulse for the switching condition of preselection 4 (→ 9.12 Preselection 1 Menu)	
OUTPUT TARGET 4	
Assignment of an output for the switching condition of preselection 4 (→ 9.12 Preselection 1 Menu) (except default value)	
	see Preselection 1 Menu
CTRL OUT 4	Assignment of the switching condition to Ctrl. Out 4
OUTPUT POLARITY 4	
Switching status for the switching condition of preselection 4 (→ 9.12 Preselection 1 Menu)	
OUTPUT LOCK 4	
Latching for the switching condition of preselection 4 (→ 9.12 Preselection 1 Menu)	
START UP DELAY 4 (S)	
Start-up delay for the switching condition of preselection 4 (→ 9.14 Preselection 3 Menu) (Start-up delays 1 and 2 are time-dependent.)	
OFF	No start-up delay
AUTO	Automatic start-up delay until the preselection value / switch point is exceeded for the first time.
EVENT COLOR 4	
Event-dependent colour change of the display for the switching condition of preselection 4, see Preselection 1 Menu	

9.16 Analog Out Menu

In this menu the basic settings for the analogue output are defined. This function is only available for the devices DX2043 and DX2053.

ANALOG SOURCE	
This parameter defines the source for preselection for the analogue output.	
INPUT 1	Source is input 1
INPUT 2	Source is input 2
LINKAGE 1 – 2	The source is the result of the linking of input 1 and input 2
INPUT 1 TOTAL	Source is input 1 with totalization
INPUT 2 TOTAL	Source is input 2 with totalization
LINKAGE TOTAL	The source is the result of the linking of input 1 and input 2 with totalization
IO LINK VALUE 1	The PDout value 1 sent by the IO-Link master is the source for preselection
IO LINK VALUE 2	The PDout value 2 sent by the IO-Link master is the source for preselection
MINIMUM VALUE 1	Source is input 1
MAXIMUM VALUE 1	Source is input 1
MINIMUM VALUE 2	Source is input 2
MAXIMUM VALUE 2	Source is input 2
ANALOG FORMAT	
This parameter defines the output characteristic. For the output format (-10 ... +10 V), the polarity of the output follows the algebraic sign in the display. The analogue output is proportional to the display value.	
-10...10V	-10 ... +10 V
0...20MA	0 ... 20 mA
4...20MA	4 ... 20 mA
ANALOG START	
With this parameter, the start value of the analogue gain can be set. The start value determines at which display value the analogue output has a gain of 0 V or 0 / 4 mA.	
-99999999	Lowest possible start value
0	Default value
+99999999	Highest possible start value
ANALOG END	
With this parameter, the end value of the analogue gain can be set. The end value determines at which display value the analogue output has a maximum value of +/- 10 V or 20 mA.	
-99999999	Lowest possible final value
10000	Default value
+99999999	Highest possible final value

ANALOG GAIN (%)

With this parameter, the maximum gain can be set. The analogue gain indicates the maximum gain of the analogue output in % referred to +/- 10 V or 20 mA.

Examples:

- 101.00 corresponds to a gain of 10.2 V / 20 mA after reaching the "Analog End" value.
- 95.00 corresponds to a gain of 9.5 V / 18 mA after reaching the "Analog End" value.

0.00	Lowest possible gain
100.00	Default value
110.00	Highest possible gain

ANALOG OFFSET (%)

With this parameter, the zero point shift of the output can be set.

Example: 0.20 corresponds to a gain of 0.2 V / 0.4 mA after reaching the "Analog Start" value.

-99.99	Lowest possible zero point shift
0	Default value
+99.00	Highest possible zero point shift

9.17 Command menu**INPUT 1 ACTION**

This parameter defines the control function of the Ctrl. In 1 input.

d = dynamic switching characteristics (edge evaluation), INPUT CONFIG must be set to RISING/FALLING EDGE

s = static switching characteristics (level evaluation), INPUT CONFIG must be set to ACTIVE LOW/HIGH

NO	No function.	
TARA INPUT 1	The value of input 1 is saved as OFFSET of input 1.	d
TARA INPUT 2	The value of input 2 is saved as OFFSET of input 2.	d
TARA INPUT 1+2	The value of input 1 is saved as OFFSET of input 1, The value of input 2 is saved as OFFSET of input 2.	d
RESET TOTAL 1	The value of totalizer 1 is reset to 0.	d, s
RESET TOTAL 2	The value of totalizer 2 is reset to 0.	d, s
RESET TOTAL 1+2	The values of totalizer 1 and 2 are reset to 0.	d, s
TEACH PRESEL. 1	Value of SOURCE 1 is saved as PRESELECTION 1.	d
TEACH PRESEL. 2	Value of SOURCE 2 is saved as PRESELECTION 2.	d
TEACH PRESEL. 3	Value of SOURCE 3 is saved as PRESELECTION 3.	d
TEACH PRESEL. 4	Value of SOURCE 4 is saved as PRESELECTION 4.	d
SCROLL DISPLAY	Display change (→ 8.2 Display during operation).	d
RESET MIN/MAX	Reset of the min. / max. values.	d, s
CLEAR LOOP TIME	N.A.	
ACTIVATE	N.A.	

STORE DATA	N.A.	
TESTPROGRAM	N.A.	
SET RED COLOR	Display is red. The colour can be changed by means of the event-dependent colour change in the PRESELECTION 1 ... 4 MENU.	d
SET GREEN COLOR	Display is green. The colour can be changed by means of the event-dependent colour change in the PRESELECTION 1 ... 4 MENU.	d
SET YELLOW COLOR	Display is yellow. The colour can be changed by means of the event-dependent colour change in the PRESELECTION 1 ... 4 MENU.	d
FREEZE	Freezes the display value.	s
KEY LOCK	Locks the keys of the touch screen.	s
LOCK RELEASE	Release latching of all outputs.	d
SERIAL PRINT	N.A.	
START PRESELECT	N.A.	
ADD TO TOTAL 1	Adds the current value of input 1 to INPUT 1 TOTAL.	d
ADD TO TOTAL 2	Adds the current value of input 2 to INPUT 2 TOTAL	d
INC. BRIGHTNESS	Increase display brightness	d, s
DEC. BRIGHTNESS	Decrease display brightness	d, s
INPUT 1 CONFIG		
This parameter defines the switching characteristics for Ctrl. In 1.		
ACTIVE LOW	Activation in case of "LOW" (static)	
ACTIVE HIGH	Activation in case of "HIGH" (static)	
RISING EDGE	Activation in case of rising edge (dynamic)	
FALLING EDGE	Activation in case of falling edge (dynamic)	
INPUT 2 ACTION		
This parameter defines the control function of the Ctrl. In 2 input. See function assignment parameter INPUT 1 ACTION.		
INPUT 2 CONFIG		
This parameter defines the switching characteristics for Ctrl. In 2. See activation assignment parameter INPUT 1 CONFIG.		
INPUT 3 ACTION		
This parameter defines the control function of the Ctrl. In 3 input. See function assignment parameter INPUT 1 ACTION.		
INPUT 3 CONFIG		
This parameter defines the switching characteristics for Ctrl. In 3. See activation assignment parameter INPUT 1 CONFIG.		

9.18 Display menu

Parameter changes are only active after quitting the menu selection.

The totalization depends on the selected operating mode (→ 9.5 IN 1 Totalization).

START DISPLAY	
This parameter defines the start display after power-on of the device.	
SINGLE	One-line display. The source has to be defined in SOURCE SINGLE.
DUAL	Two-line display. The sources have to be defined in SOURCE DUAL TOP / DOWN.
LARGE	Large display (only if parameter LARGE DISPLAY is activated) The source has to be defined in SOURCE LARGE.
QUICKSTART	Display with quick-start function. Only for DX20x2, DX20x3, DX20x5.
MINIMUM / MAXIMUM	Display of the actual / minimum / maximum values of input 1 and input 2.
DUAL WITH UNIT	Two-line display with units. The sources have to be defined in SOURCE DUAL TOP / DOWN.
SOURCE SINGLE	
This parameter defines the source for preselection for a one-line display.	
INPUT 1	Source is input 1
INPUT 2	Source is input 2
LINKAGE 1 – 2	The source is the result of the linking of input 1 and input 2
INPUT 1 TOTAL	Source is input 1 with totalization
INPUT 2 TOTAL	Source is input 2 with totalization
LINKAGE TOTAL	The source is the result of the linking of input 1 and input 2 with totalization
IO LINK VALUE 1	The PDout value 1 sent by the IO-Link master is the source for preselection
IO LINK VALUE 2	The PDout value 2 sent by the IO-Link master is the source for preselection
MINIMUM VALUE 1	Source is input 1
MAXIMUM VALUE 1	Source is input 1
MINIMUM VALUE 2	Source is input 2
MAXIMUM VALUE 2	Source is input 2
SOURCE DUAL TOP	
This parameter defines the source for preselection for the first line of a two-line display.	
INPUT 1	Source is input 1
INPUT 2	Source is input 2
LINKAGE 1 – 2	The source is the result of the linking of input 1 and input 2
INPUT 1 TOTAL	Source is input 1 with totalization
INPUT 2 TOTAL	Source is input 2 with totalization

LINKAGE TOTAL	The source is the result of the linking of input 1 and input 2 with totalization
IO LINK VALUE 1	The PDout value 1 sent by the IO-Link master is the source for preselection
IO LINK VALUE 2	The PDout value 2 sent by the IO-Link master is the source for preselection
MINIMUM VALUE 1	Source is input 1
MAXIMUM VALUE 1	Source is input 1
MINIMUM VALUE 2	Source is input 2
MAXIMUM VALUE 2	Source is input 2
SOURCE DUAL DOWN	
This parameter defines the source for preselection for the second line of a two-line display.	
INPUT 1	Source is input 1
INPUT 2	Source is input 2
LINKAGE 1 – 2	The source is the result of the linking of input 1 and input 2
INPUT 1 TOTAL	Source is input 1 with totalization
INPUT 2 TOTAL	Source is input 2 with totalization
LINKAGE TOTAL	The source is the result of the linking of input 1 and input 2 with totalization
IO LINK VALUE 1	The PDout value 1 sent by the IO-Link master is the source for preselection
IO LINK VALUE 2	The PDout value 2 sent by the IO-Link master is the source for preselection
MINIMUM VALUE 1	Source is input 1
MAXIMUM VALUE 1	Source is input 1
MINIMUM VALUE 2	Source is input 2
MAXIMUM VALUE 2	Source is input 2
LARGE DISPLAY	
This parameter switches the large display on and off. Via the divider ratio, the display value can be divided for the large display.	
NO	Large display switched off
1:1	Large display with divider ratio 1:1
1:10	Large display with divider ratio 1:10
1:100	Large display with divider ratio 1:100
1:1000	Large display with divider ratio 1:1000
1:10000	Large display with divider ratio 1:10000
SOURCE LARGE	
This parameter defines the source for a one-line display. Parameter only visible with activated parameter LARGE DISPLAY.	
INPUT 1	Source is input 1

INPUT 2	Source is input 2
LINKAGE 1 – 2	The source is the result of the linking of input 1 and input 2
INPUT 1 TOTAL	Source is input 1 with totalization
INPUT 2 TOTAL	Source is input 2 with totalization
LINKAGE TOTAL	The source is the result of the linking of input 1 and input 2 with totalization
IO LINK VALUE 1	The PDout value 1 sent by the IO-Link master is the source for preselection
IO LINK VALUE 2	The PDout value 2 sent by the IO-Link master is the source for preselection
MINIMUM VALUE 1	Source is input 1
MAXIMUM VALUE 1	Source is input 1
MINIMUM VALUE 2	Source is input 2
MAXIMUM VALUE 2	Source is input 2
COLOR	
This parameter defines the display colour.	
The colour can be changed by means of the event-dependent colour change in the PRESELECTION 1 ... 4 MENU. Event-dependent colour change is only available for the devices DX2042, DX2043, DX2052 and DX2053.	
RED	The display is red.
GREEN	The display is green.
YELLOW	The display is yellow.
BRIGHTNESS (%)	
This parameter defines the display brightness in %.	
10	Minimum display brightness
80	Default value
100	Maximum display brightness
CONTRAST	
This parameter defines the display's angle of view.	
0	Angle of view from above
1	Angle of view from the front
2	Angle of view from below
SCREEN SAVER (S)	
This parameter defines the time in seconds after which the display is switched off.	
0	Display stays on
...	
9999	Longest time until the display is switched off
UP-DATE-TIME (S)	
This parameter defines the display refreshing time in seconds.	

0.005	Minimum update time
0.1	Default value
9.999	Maximum update time
FONT	
With this parameter, the font of the clear text can be selected.	
0	Standard
1	Font 1

10 Linearization

With this function, a linear input signal can be converted into a non-linear visualisation (or the other way round). Up to 24 linearization points are available for input 1 and input 2. They can be distributed across the whole conversion area at any distances. There is automatic linear interpolation between 2 predefined coordinates.

It is recommended to set as many points as possible in sections where curves are strongly bent. In sections with slight curve bending, only a few points are sufficient. To predefine a linearization curve the LINEARIZATION MODE parameter has to be set to 1 QUADRANT or 4 QUADRANT in the IN1 Properties and IN 2 Properties menus (see diagram below).

Up to 24 X coordinates can be defined via the parameters P1(X) to P24(X) in the IN 1 Linearization and IN 2 Linearization menus. They correspond to the display values without linearization.

With the parameters P1(Y) to P24(Y), you can enter the values which the display should indicate instead of the X values. Value P5(X) is replaced by value P5(Y), for example.

The X coordinates have to be assigned with continuously increasing values. That means P1(X) is the lowest value; every following value must be higher. In case of measured values that are higher than the X value that was defined last, the corresponding Y value is constantly displayed.

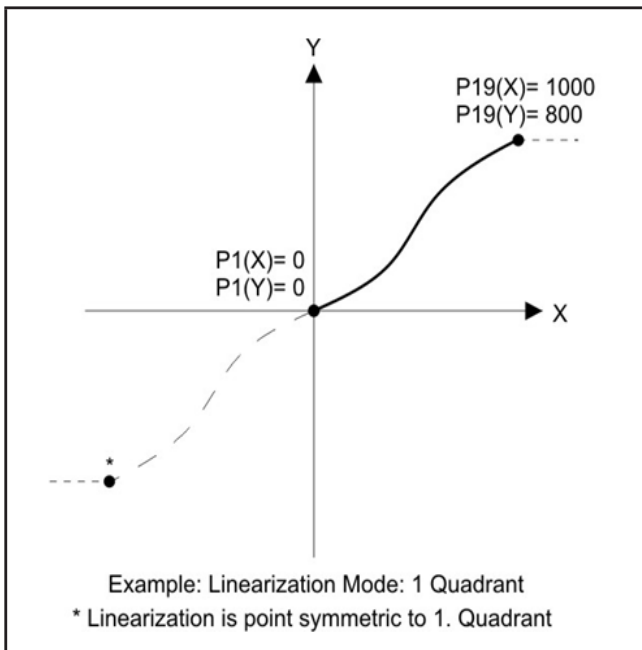

Mode 1 Quadrant:

P1(X) must be set to 0. Linearization is only defined in the positive value range.

With negative measured values, the curve is mirrored point-symmetrically.

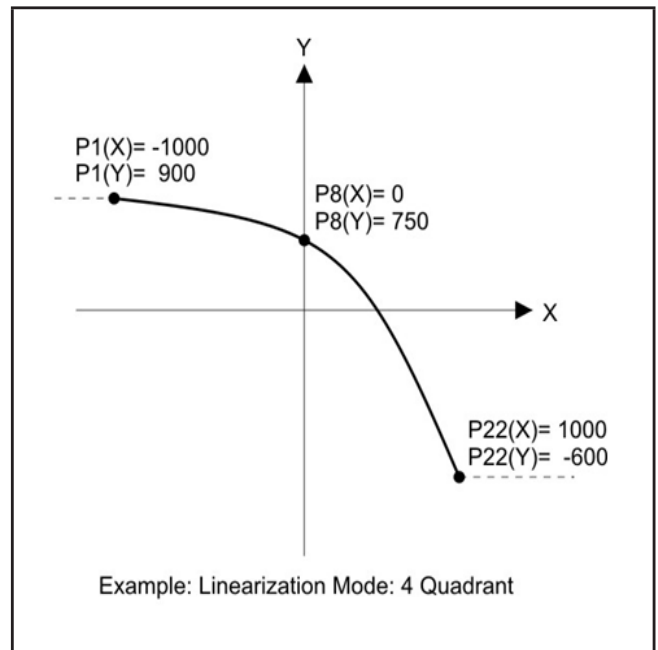

Mode 4 Quadrant:

P1(X) can also be set to negative values. With measured values lower than P1(X) the value P1(Y) is constantly displayed.

Application example: linearisation

Using a pressure sensor, the level (volume) of a tank is to be determined and displayed. The analogue signal of the sensor is proportional to the level, but due to the shape of the tank, it is not proportional to the volume.

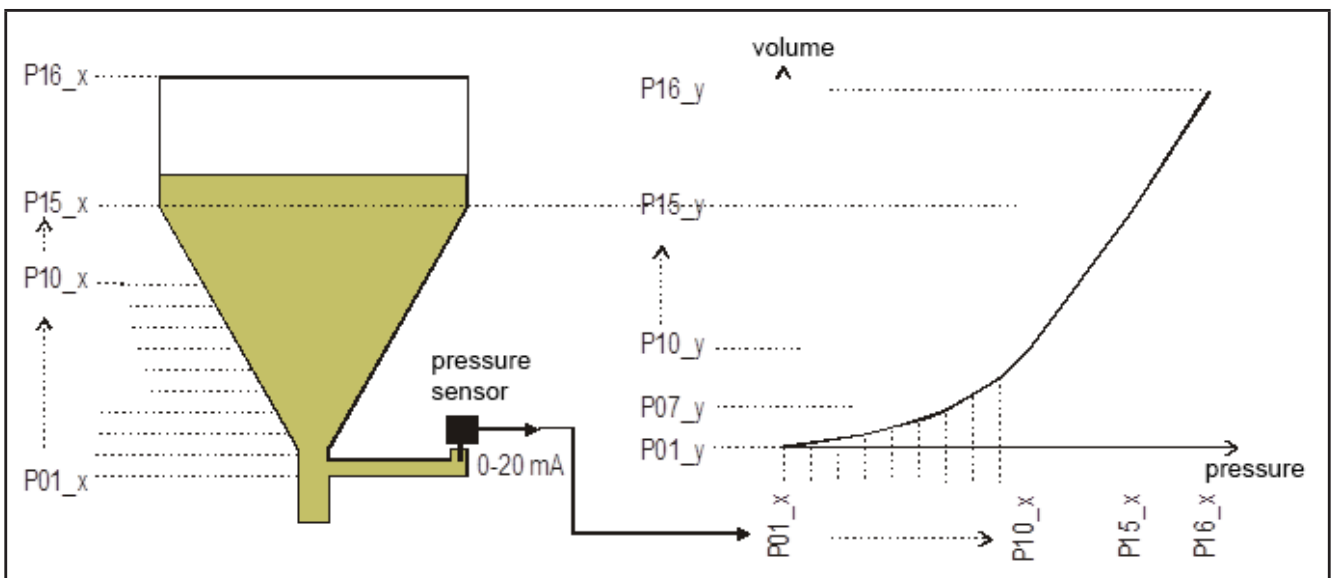

Application example: volume calculation

11 Technical data

Voltage supply (DC):	Input voltage:	18 ... 30 VDC
	Protection circuit:	reverse polarity protection
	Current consumption:	approx. 100 mA (without load)
	Protection:	external: T 0.5 A
Voltage supply (AC): (DX204x)	Input voltage:	115 ... 230 VAC ($\pm 10\%$; 50 ... 60 Hz)
	Power consumption:	approx. 3 VA (without load)
	Protection:	external: T 0.1 A
Connections:	Connection type:	screw terminals, 1.5 mm ² / AWG 16
Sensor supply:	In case of DC supply:	approx. 1 V lower than the input voltage
	Output current:	max. 250 mA
	In case of AC supply:	approx. 24 V ($\pm 15\%$)
	Output current:	150 mA (at max. 45 °C) / 80 mA (at > 45 °C)
Reference output:	Output voltage:	10 V
	Accuracy:	$\pm 0.1\%$
	Load:	max. 10 mA / ≥ 1 kohms
Analogue inputs:	Number	2
	Configuration	voltage input or current input
	Voltage input	-10 ... 10 V ($R_i \approx 33$ kohms)
	Current input	0 ... 20 mA / 4 ... 20 mA ($R_i \approx 120$ ohms)
	Resolution	16 bits
	Accuracy:	$\pm 0.1\%$
Control inputs:	Number:	3
	Format:	HTL, PNP (LOW 0 ... 3 V, HIGH 9 ... 30 V)
	Frequency:	max. 1 kHz
	Load:	max. 2 mA at 24 VDC
Analogue output: (DX2043, DX2053)	Configuration:	current or voltage output
	Voltage output:	-10 ... +10 V (max. 2 mA)
	Current output:	0 ... 20 mA / 4 ... 20 mA (load max. 270 ohms)
	Resolution:	16 bits
	Accuracy:	$\pm 0,1\%$ 0°C ... +45°C $\pm 0,15\%$ -20°C ... 0°C and +45°C ... +60°C
	Response time:	< 10 ms (software: AX35006F or higher)

UK

Control outputs: (DX20x2, DX20x3, DX20x5)	Number:	4
	Format / level:	5 ... 30 V (depending on the voltage on Com+), PNP
	Output current:	max. 200 mA
	Response time:	< 1 ms
IO-Link:	IO-Link revision:	1.1
	Type of transmission:	COM3
	Master port class:	A
Display:	Type:	graphic LCD with backlight
	Display range	8 decades plus sign (-99999999 ... +99999999)
	Character height	13 mm
	Colour:	red / green / yellow (selectable)
	Operation:	touch screen (resistive)
Housing:	Material:	ABS, UL 94 V-0
	Installation:	panel mounting
	Dimensions (W x H x D):	96 x 48 x 116 mm
	Section (W x H):	91 x 43 mm
	Protection rating:	IP 65 front, IP 20 back
	Weight:	approx. 200 g
Ambient temperature:	Operation:	-20 °C ... 60 °C
	Storage:	-25 °C ... 70 °C

12 Maintenance, repair and disposal

12.1 Maintenance

In case of regular operation, no maintenance measures are necessary for the unit. In case of unexpected problems, errors or functional failures, the unit must be sent to the manufacturer to be examined and, if necessary, repaired. Unauthorised opening and set-up may impair the functioning of the unit or cause failure of the protective measures supported by the unit.

12.2 Cleaning the housing surface

- ▶ Clean the device from dirt using a soft, chemically untreated cloth.
- ▶ The competent maintenance staff or the corresponding installer is responsible for unscheduled cleaning.

12.3 Repair

- ▶ The device must only be repaired by the manufacturer.
Observe the safety instructions (→ 2 Safety instructions).

12.4 Disposal

- ▶ Dispose of the device in accordance with the national environmental regulations.