



LX341 / LX342

Replaces MX341 / MX342

Instruction Manual V1.4

Product version V1.1.3.0

WARNINGS AND COMMISSIONING INFORMATION



HAZARDOUS VOLTAGES.



DO NOT OPERATE WHEN NOT FAMILIAR WITH GENERATORS.

- **Check the isolation of the generator windings before installation.**
Poor isolation will cause damage to the AVR and dangerous situations for persons.
- The system should not be installed, operated, serviced or modified except by qualified personnel who understand the danger of electric shock hazards and have read and understood the user instructions.
- Never work on a LIVE generator. Unless there is another person present who can switch off the power supply or stop the engine.
- Dangerous voltages are present at the voltage regulator board. Accidental contact with live conductors could result in serious electrical shock or electrocution.
- Disconnect the power source before making repairs, connecting test instruments, or removing or making connections to the voltage regulator or generator.
- Defects in the generator or AVR may cause consequential loss. Precautions must be taken to prevent this from occurring.
- The unit should be installed with respect to the environmental specifications as well as the rules mentioned in the General installation information.
- For safety reasons the voltage level potentiometers are best turned completely counter clockwise in order to start at the lowest possible voltage.
- Never change the rotary switch or dipswitch settings during operation.
- Never apply supply voltage when generator is not running, unless exciter field is disconnected.

REVISION HISTORY

Product	Version				Change
	Hardware	Software	Manual	Date	
V1.0.0.0	1.0	1.0	1.0	May-2019	<i>First release.</i>
V1.1.0.0	1.1	1.1	1.1	Nov-2019	<i>Components moved. Changed time protections, see page 5.</i>
V1.1.1.0	1.1	1.2	1.2	Apr-2020	<i>Improved "Loss of sensing" protection.</i>
V1.1.2.0	1.1	1.4	1.3	Oct-2020	<i>Improved frequency measurement.</i>
V1.1.3.0	1.1.1	1.4	1.4	Oct-2021	<i>Added Commissioning for external hand trimmer</i>

The table provides a historical summary of the changes made to the AVR.
Revisions are listed in chronological order.

The manual does not cover all technical details of the product. Specifications may be modified by the manufacturer without notice. For further information, the manufacturer should be contacted.

TABLE OF CONTENTS

General description	3
Absolute maximum ratings	4
Protections	5
Modes of control I	6
- <i>Buildup</i>	
- <i>Underspeed UFRO</i>	- <i>Underspeed DIP</i>
- <i>Stability control</i>	- <i>Droop</i>
Modes of control II	7
- <i>Setpoint control</i>	- <i>Remote adjust</i>
- <i>I-Limit</i>	
Quick reference I & II	8
- <i>Hardware connections</i>	- <i>Factory settings & Status LED</i>
- <i>Potentiometers</i>	- <i>Rotary switches</i>
Wiring diagrams	10
Commissioning	12
General installation information	15
Contact	16

GENERAL DESCRIPTION

The AVR is designed as a replacement for the MX341 & MX342, providing optimal flexibility and configurability as is reflected by the additional capabilities of the AVR. Nevertheless installation, maintenance and adjustment don't require special application software. The AVR is protected from the environment by a PUR coating.

Mode of control	MX341	MX342	AVR
Constant voltage control	✓	✓	✓
Quadrature voltage droop for parallel operation	✓	✓	✓
Current control (Current limiting)		✓	✓
Protection			
Generator phase loss			✓
AVR over temperature			✓
Generator over voltage			✓
Generator over current			✓
Generator over excitation	✓	✓	✓
User adjustable underspeed knee	✓	✓	✓
User adjustable underspeed slope	✓		✓
User adjustable over excitation current			✓
User adjustable generator current limit		✓	✓
Communication			
AVR Status LED	✓	✓	✓

Options		Terminals
DROOPKIT	Required for parallel operation / current limiting	S1 – S2
DFD7.5	Diode failure detector	Separate unit

ABSOLUTE MAXIMUM RATING

Symbol	Parameter	Condition	Min.	Max.	Unit
2, 3	Voltage sensing input	50 - 60Hz, Intermitted < 30s.	-	270	V _{AC}
X, XX	AVR field current	Continuous ⁽¹⁾	-	2.7	A _{DC}
		Intermitted < 10s.	-	6	A _{DC}
	Field resistance X(+), XX(-)	@ 70V _{AC} supply ^{(3) (4)}	6.6	-	Ω
		@ 170V _{AC} supply	16	-	Ω
P2, P3, P4	Supply input (PMG)	DC or 25 - 400Hz.	15	220	V _{AC}
		Supply must be isolated.	15	135	V _{DC}
A1, A2	Accessories input	A1(-), A2(+) ⁽²⁾ Connected device must be isolated.	-13	+13	V _{DC}
S1, S2 (W)	Droop, Limit CT	CT > 2VA, Intermitted < 30s. CT must be isolated.	-	1	A _{AC}
T _{AMB}	Operating temperature	95% RHD non condensing ⁽¹⁾	-40	+70	°C
T _{STG}	Storage temperature	95% RHD non condensing	-40	+85	°C
	Static control accuracy			1	%

⁽¹⁾ Always mount with heatsink fins aligned vertically and allow for sufficient airflow.

⁽²⁾ Input resistance is 9.3KΩ.

⁽³⁾ See table below for safe operation area of the AVR.

⁽⁴⁾ See formula for calculating minimum field resistance.

Field resistance (Ω) ≥ $\frac{\text{Supply input} \times \sqrt{2} (V_{DC})}{15}$

Stresses above “Absolute Maximum Ratings” may cause permanent damage to the device. This is a stress rating only, the functional operation of the device or any other conditions indicated in the “operation area” of this specification is not implied. Exposure to maximum rating conditions for extended periods may affect device reliability and lifetime.

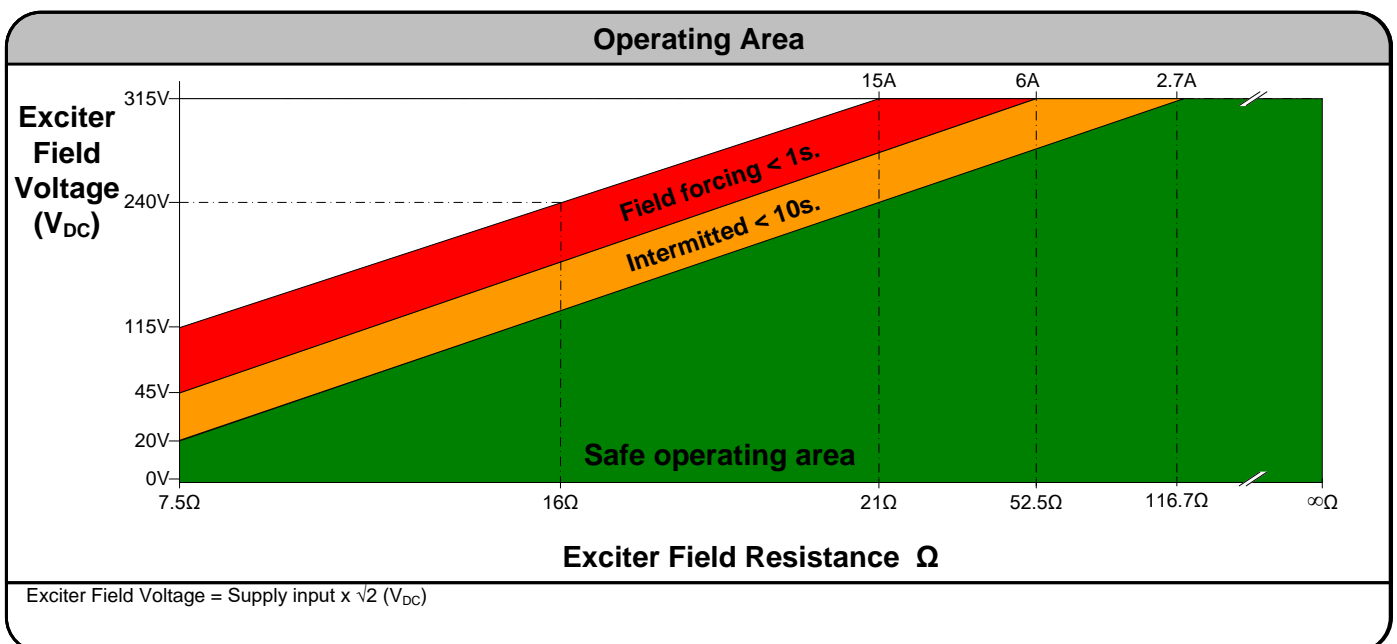

PROTECTIONS

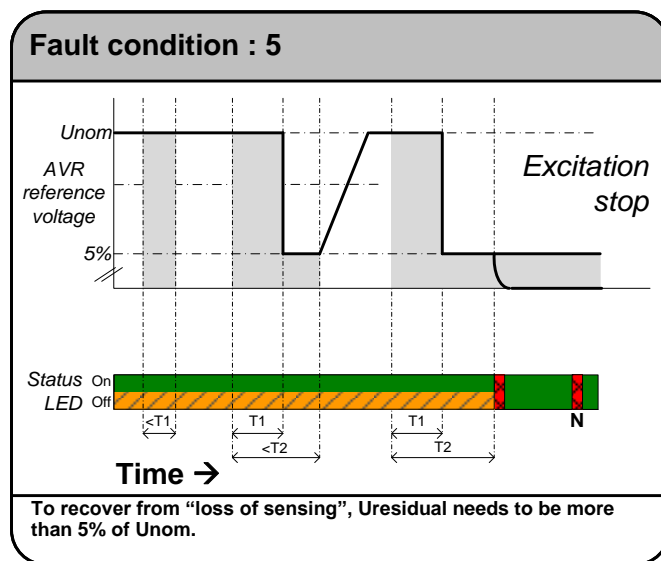
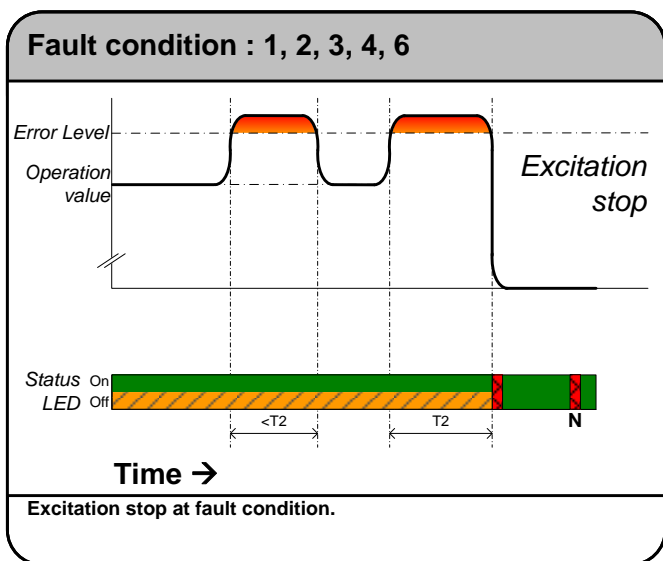

Protection	n	Fault Condition	T1	T2
Over voltage	1	275V at voltage sensing input 2-3	n.a.	2 s.
Over current	2	1A at current sensing input S1-S2	n.a.	15 s.
Over excitation	3	7A	n.a.	10 s.
Over temperature AVR	4	95 °C	n.a.	40 s.
Loss of sensing	5	Loss of sensing < 5% of Unom	2.5 s.	20 s.
100% excitation	6	Output excitation voltage 100%	n.a.	10 s.

To recover from "loss of sensing", Uresidual needs to be more than 5% of Unom.

When a fault condition is active for more than time **T2**, the AVR stops field excitation. The fault is indicated by the status led with **(N)umbers of red blinks**.

To **reset** the fault, shut down the generator or open contact K1-K2.

MODES OF CONTROL I

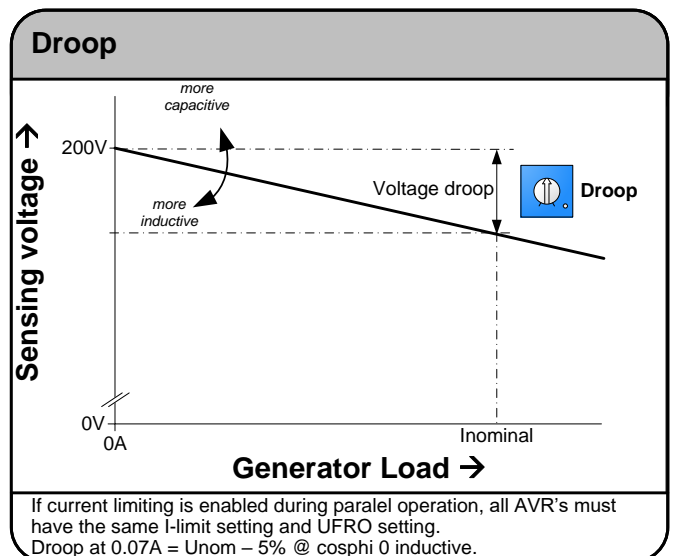
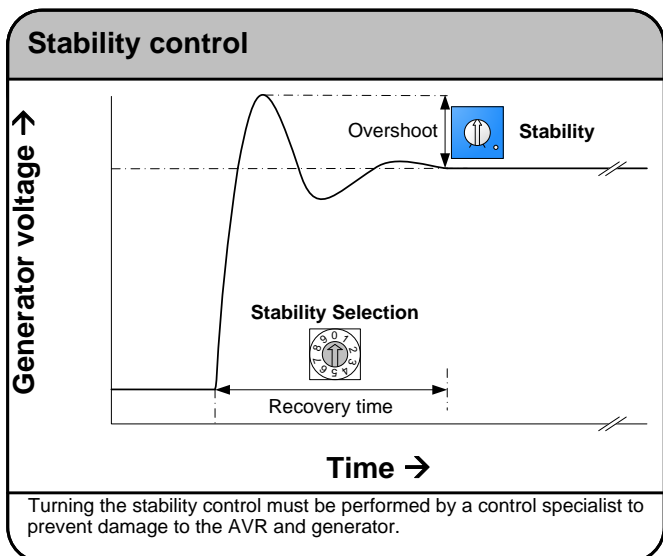
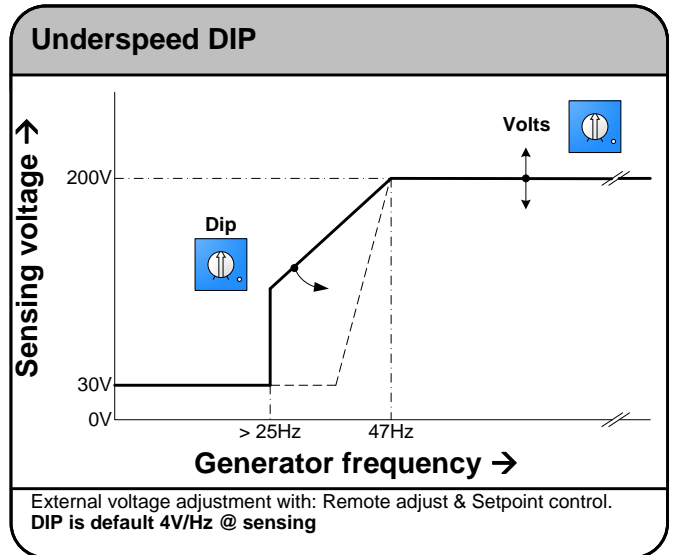
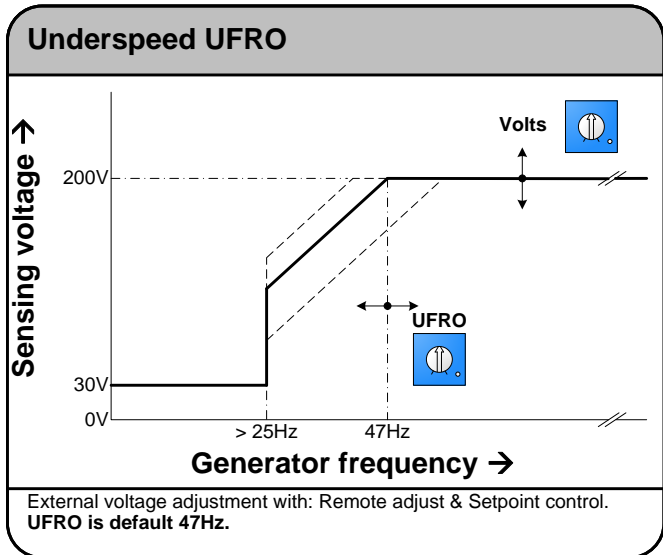
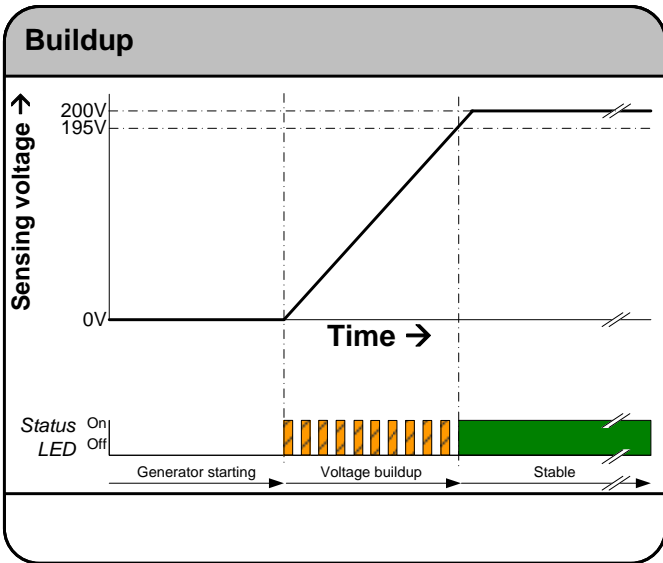

MODES OF CONTROL II

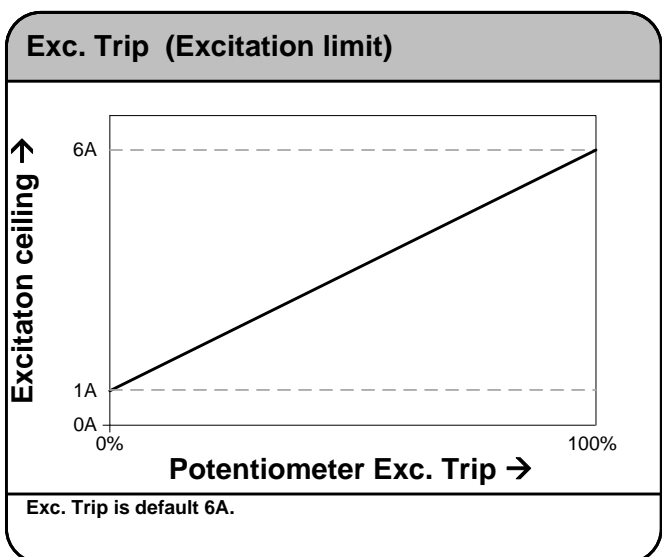
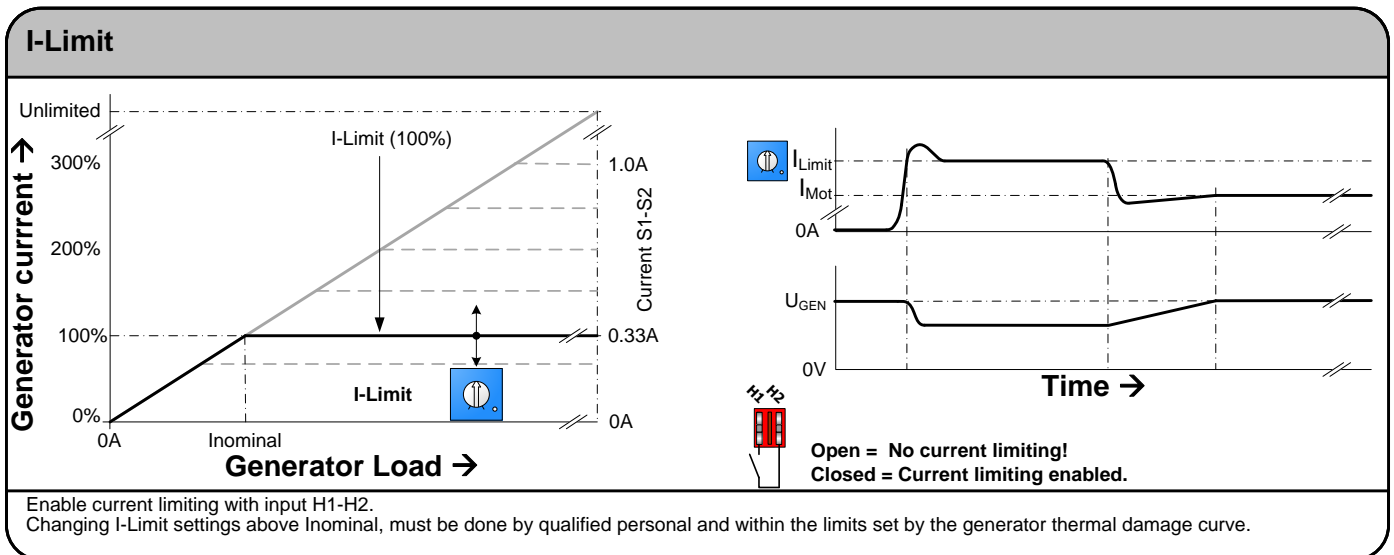
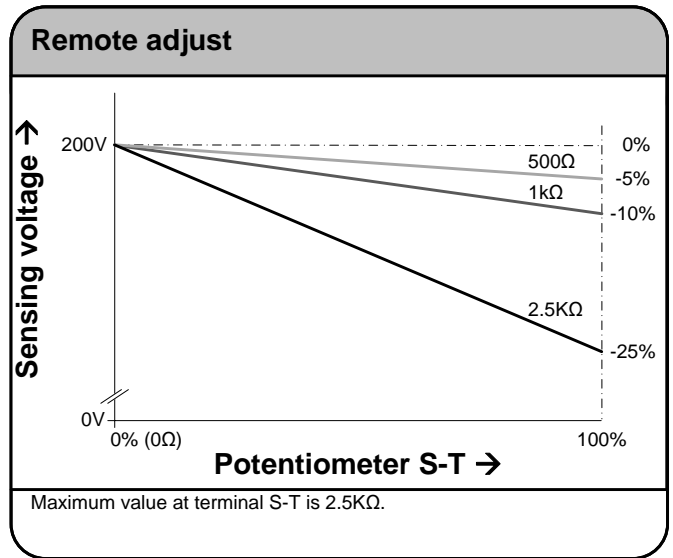
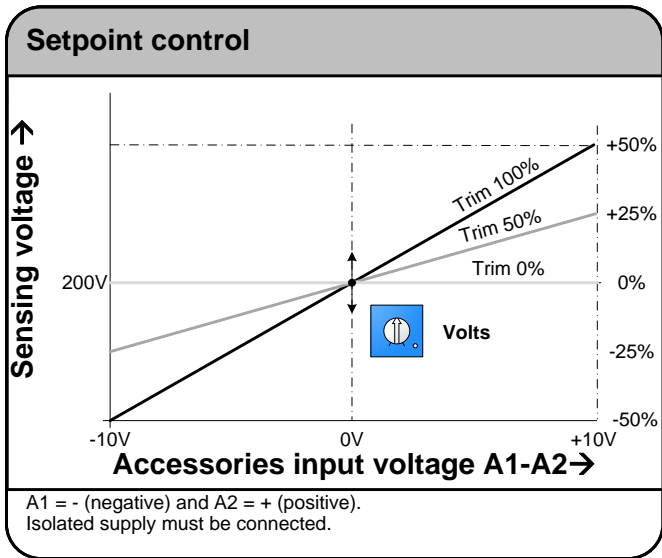

QUICK REFERENCE I

AVR Supply (Page 10,11)
15 .. 220Vac

Never fit or remove link during operation! Contact can result in serious electrical shock.

Link

Supply on/off

K1 K2 P2 P3 P4

Exciter (Page 10,11)
0 .. 2.7Adc

Max. rating: Intermittent 6A < 10s.

Check **Formula**

Minimum Field Resistance (Page 4, 9)

Exciter Field

XX X

Sensing (Page 10,11)
0 .. 250Vac

U-V-W clockwise

U V W

3 2

11

130

11

10.5 115 10.5

K1 K2 P2 P3 P4 XX X 3 2

Trim A1 A2

Droop S1 S2

Volts fine

Volts coarse

Product information

- Measurements in mm.
- Size is 136mm x 152mm.
- Height is +/- 37mm.
- Weight is +/- 0.5Kg.
- Mounting 1:1 MX341/MX342

I-Limit

Exc. Trip

Stability Selection

DIP

Ø5.5MM

UFRO

Status LED

S

H1 H2

Stability

Remote adjust (Page 7)

S A

(No potentiometer)

0..2.5kΩ

Max. value : 2.5K

Digital input (Page 7)

H1 H2

Open = No current limiting !
Closed = Current limiting enabled.
(Open for LX341 / Closed for LX342)

QUICK REFERENCE I I

Volts (Page 6)

fine

-1.5%  +1.5%

coarse

150V  250V

Stability selection (Page 6)



0 < 10kW 5 < 1000kW
 1 < 45kW 6 < 1500kW
 2 < 90kW 7 < 2000kW
 3 < 250kW 8 < 3000kW
 4 < 550kW 9 < 5000kW

UFRO (Page 6)

Underspeed knee

60Hz  40Hz



+/- 57Hz +/- 47Hz

Stability (Page 6)

Decrease stability -  + Increase stability

DIP (Page 6)



Underspeed slope

4V/Hz  16V/Hz

(Slope @ sensing)



Accessories input (Page 7)

Max. rating: -13V .. +13V

A1  A2  Isolated supply (-10V .. +10V)

Trim  0% 100%

Current sensing (Page 7, 10, 11)

S1  S2  W phase (Original Newage CT) 0.33A 0.33A = 100% Igen

I-Limit  60% 300%

See H1-H2 input

I-Limit (Page 7)

60%  300%

CT:0.33A







See H1-H2 input

Factory settings

Control mode	: Constant voltage
Sensing	: 200V
UFRO	: 47Hz.
DIP	: 4V/Hz @ sensing
Droop	: 0V
I-Limit	: 0.41A (I-limit Off)
H1-H2	: No link (I-limit Off)
Exc. Trip	: 6A
Stability	: 50 %
Stability selection	: Pos. 4
Trim	: 100 % (1V/5%)

Link: K1-K2, S-T

Status Led

Orange Blink		Buildup
Green Continuous		Voltage control
Orange Continuous		Current control
Green with Orange blink		Underspeed (>25Hz.)
Red Continuous		Underspeed (<25Hz.)
Green with Red blink		Error: (n) number of red blinks

n	Error
1	Over voltage
2	Over current
3	Over excitation
4	Over temperature AVR
5	Loss of sensing
6	100% excitation

Droop (Page 6)

0%  100%

Exc. Trip (Page 7)

1A  6A

Minimum Rfield

Formula

Minimum field resistance

$$\text{Field resistance } (\Omega) \geq \frac{\text{Supply input} \times \sqrt{2} (V_{DC})}{15}$$

Trim (Page 7)

0%  100%

% of input A1-A2

WIRING DIAGRAM I

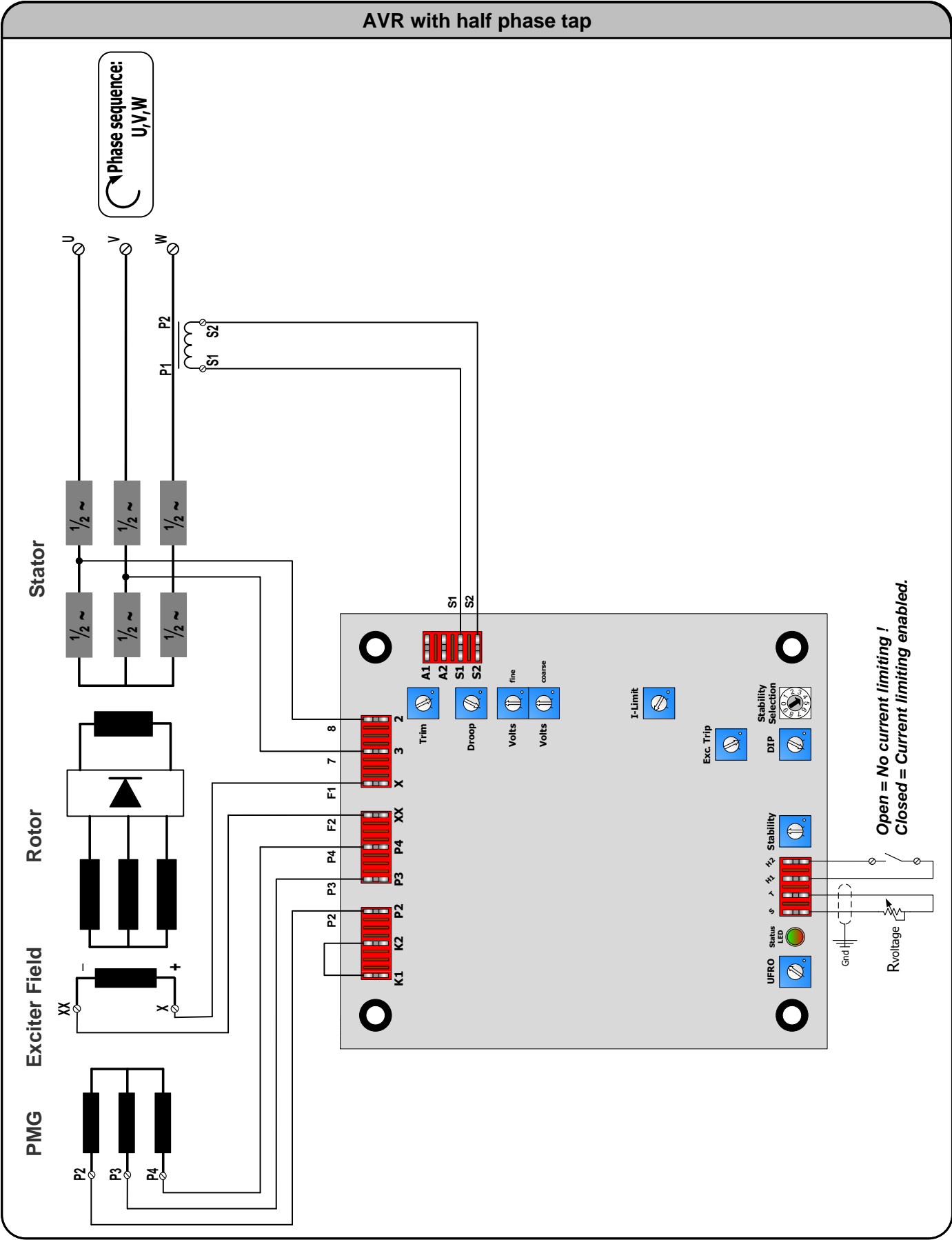

WIRING DIAGRAM II

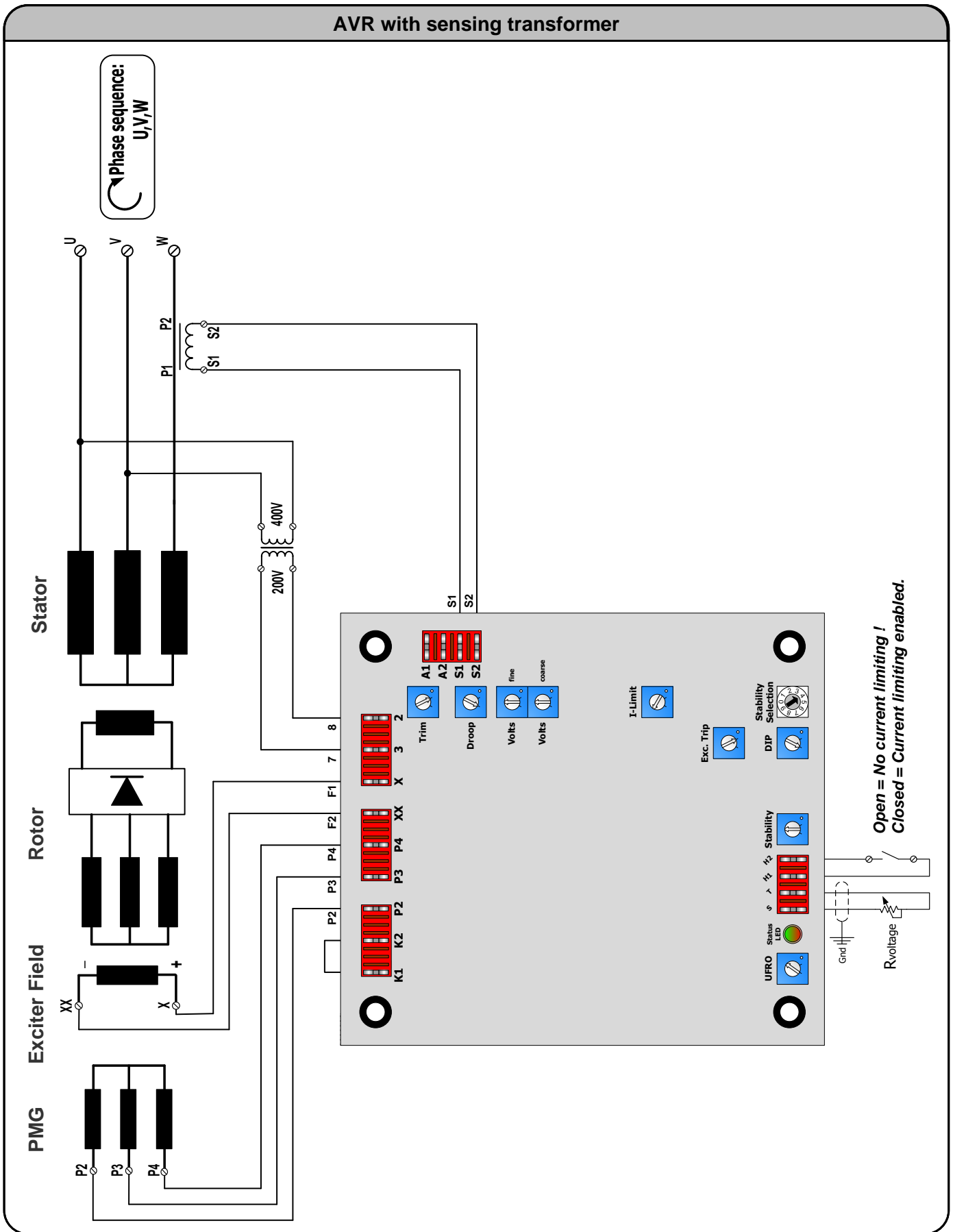

COMMISSIONING I

Commissioning : Underspeed protection

Start (AVR Active / Generator running !)

Underspeed protection

Set speed

Set nominal speed.

Threshold UFRO



Indication setpoints

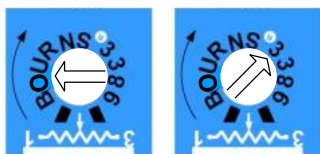

+/- 57Hz

+/- 47Hz

Setpoint UFRO

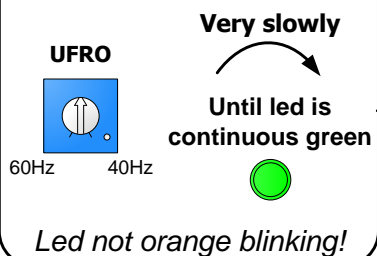

Led not orange blinking!

Note:

It is recommended to turn the potentiometer a little further clockwise, to allow for short frequency dips.

Done

COMMISSIONING II

Commissioning : External hand trimmer

AVR without remote adjust

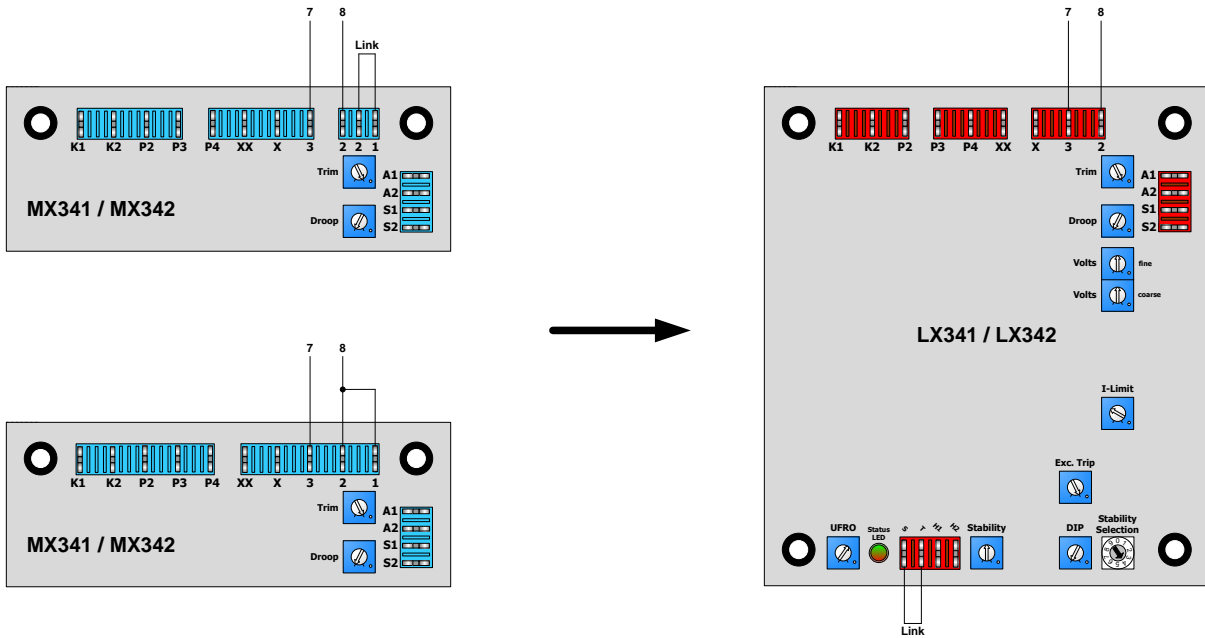

AVR with remote adjust

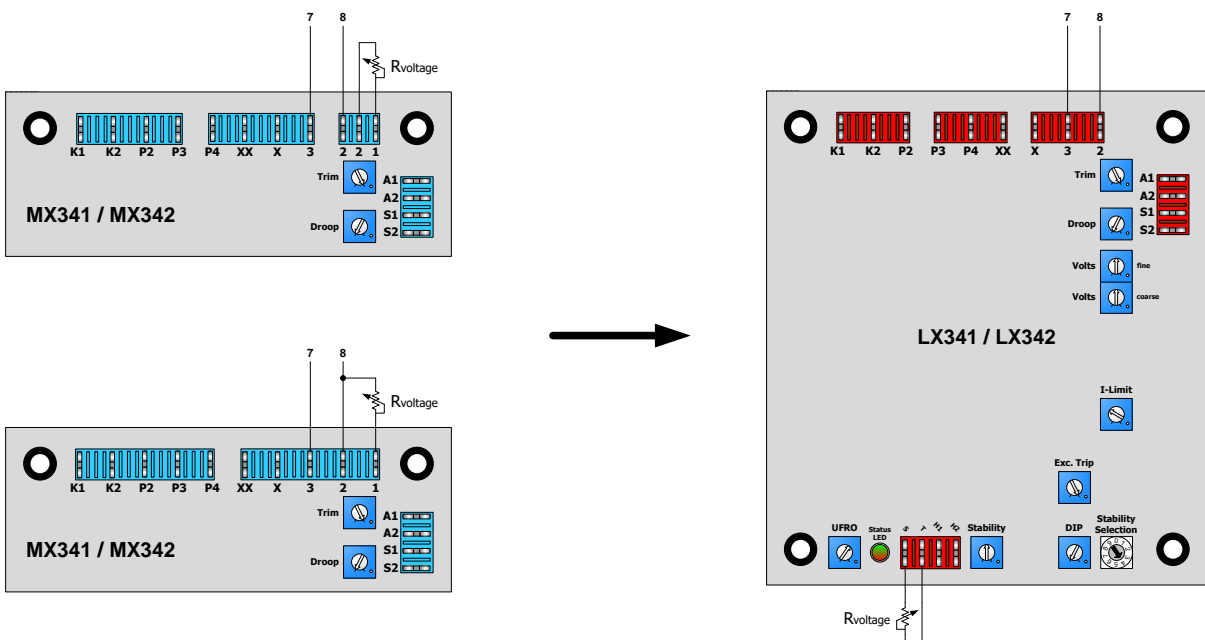

**Potentiometer Rvoltage must only be connected to terminal S & T. (Isolated from sensing voltage)
Make sure that potentiometer is not connected in any way to terminal 1, 2 or 3 or wire 7 or 8.**

Empty page

GENERAL INSTALLATION INFORMATION

Absolute Maximum Ratings

- The Absolute Maximum Ratings are those limits for the device that, if exceeded, will likely damage the device. Exceeding the absolute maximum ratings voids any warranty and/or guarantee.

Mounting

Mounting of the product should be done in such a way that:

- the absolute maximum ambient temperature rating of the product will never be exceeded.
- maximum cooling (direction of cooling ribs and direction of airflow) is achieved.
- Mounting no humid air can flow through the product or condensation occurs.
- dust or other materials or residue will not remain in or on the product.
- the maximum vibration is not exceeded.
- personal contact with persons is impossible.

Wiring

- Diameter size of the wiring should be enough to carry the expected current. Wire insulation should be enough to withstand the expected operating voltages and temperatures.
- To improve EMC emission and immunity, care should be taken for the lay out of the wiring. This in respect to all wiring in the installation.
- Keep current carrying wires as short as possible.
- Keep wires carrying a total sum of zero Ampere close to each other, or in one single cable, E.g. U, V, W, or X (+) and XX (-), or Phase and neutral, or S and T.
- Avoid current carrying conductors next to sensing or control wiring. Especially current controlled by SCR's or PWM controlled transistors.
- If sensitive sensing signal cables need to be laid across distance along other cabling, shielded cable is preferred. Keep the shield as long as possible and the wiring outside the shield as short as possible. Do not solder or shrink the shield to a regular wire. Connect the original shield to ground at one side with an as large as possible contact surface.

Additional installation information

- When the product is supplied by means of a transformer, it should never be an auto-transformer. Auto-transformers react as voltage sweep up coil and may cause high voltage peaks.
- Standard fit capacitors or over-voltage suppressers across X (+) and XX (-), or exciter field terminals inside the generator should be removed.
- When the product is supplied by means of a transformer, it should be able to carry at least the maximum expected current. Advisable is, to have a transformer which can carry twice the maximum expected current. Inductive loads make voltage sags and peaks into the secondary voltage of a transformer, from which the device may malfunction.
- It is not recommended to apply switches in dc outputs. It is preferred to use switches in the ac supply inputs of devices. In case it is unavoidable to have switches in the dc output of a device, action must be taken to avoid over voltage damage to the device due to contact arcing. Use a voltage suppressor across the output.
- It is not recommended to apply switches or fuses in the sensing lines. Defects can cause high voltage situations due to over-excitation.
- When using a step down transformer in medium or high voltage generators, the transformer should be three phase (if three phase sensing), and the transformer should be suitable for acting as a sensing transformer. If the transformer is unloaded, connect a resistor to avoid voltage waveform distortion.
- The phase relation from the generator to the AVR is important. Also when voltage transformers and/ or current transformers are installed.
- When using a step down or insulation transformer in the droop circuit, phase relation from the generator to the AVR is important.
- CT's wiring, connected to the AVR should never be grounded.
- Always disconnect electronic products, circuits and people before checking the insulation resistance (Megger check).
- Due to differences in generators impedance's, EMC behavior is not predictable. Therefore the commissioner / installer should be aware of proper and correct installation.
- Large, highly inductive, exciter stator windings can cause destructive high voltage peaks. Adding a resistor from 10 to 20 times the exciter stator field resistance reduces voltage spikes. If necessary filter can be fitted additionally. (e.g. snubber, RC-network)
- Upon problems during commissioning, faulty behavior or defects in the generator, consult the fault finding manual at our web site
- Some advises may be overdone or seem extraordinary, but since the electrical rules are the same everywhere, these advises are given.

CONTACT

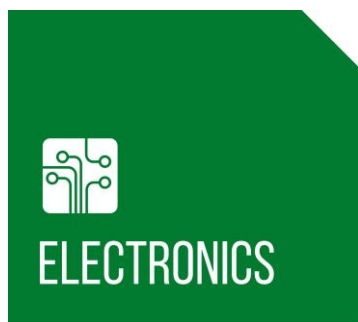

EMRI Electronics B.V.
Morsestraat 10
6716 AH, Ede, Netherlands
Tel: +31 (0)318 620 427
Website: www.emri.nl
E-mail: info@emri.nl

Manufacturer



CANARY ISLANDS, Las Palmas
Zamakona Yards
Tel: +34 928467521
Fax: +34 928461233
Website: www.zamakonayards.com/
E-mail: ibetancor@zamakonayards.com

CHILE, Santiago
Lucio Vicencio y CIA.LTDA
Tel: +1-281-334-2904
Fax: +1-832-221-5642
Website: www.luciovicencio.cl
E-mail: luciovincencioltda@gmail.com

GREECE, Piraeus
Stavros Kassidiaris S.A.
Tel: +30 210 4636000
Fax: +30 210 4624471
Website: www.kassidiaris.gr
E-mail: info@kassidiaris.gr

ICELAND, Hafnarfjordur
Rafeining ehf
Tel: +354 565 3049
Fax: +354 565 3048
Website: www.rafeining.is
E-mail: rafeining@rafeining.is

INDIA, Faridabad
Power Solutions
Tel: +91 9868907903
Fax: +91 129 2431216
Website: www.psolindia.com
E-mail: ramesh.powersolutions@gmail.com

NORWAY, Bergen
Frydenbø Electric A/S
Tel: +47 55 34 91 00
Fax: +47 55 34 91 10
Website: www.frydenbo.no
E-mail: firma.fel@frydenboe.no

POLAND, Gdynia
An-Elec Sp. z o.o.
Tel: +48 58 668 44 00
Fax: +48 58 668 44 66
Website: <http://an-elec.pl>
E-mail: info@an-elec.pl

POLAND, Szczecin
MARCONTREL
Tel: +48 91 4 888 474
Fax: +48 91 4 888 475
Website: www.marcontrol.com
E-mail: emri@marcontrol.com

POLAND, Szczecin-Mierzyn
Marel Serwis
Tel: +48 91 48 58 388
Fax: +48 91 48 79 948
Website: www.marel.szczecin.pl
E-mail: handel@marel.szczecin.pl

REPUBLIC OF PANAMA, Panama
PASRAS S.A.
Tel: +507 3140095
Fax: +507 3140094
Website: www.pasras.com
E-mail: info@pasras.com

ROMANIA, Constanta
SAMTEC SRL
Tel: +40 241 517 047
Fax: +40 241 517 047
Website: www.samtec.ro
E-mail: samtec_srl@yahoo.com

SINGAPORE, Singapore
Cyclelect Electrical Engineering
Tel: +65 6868 6013
Fax: +65 6863 6260
Website: www.cyclelect.com.sg
E-mail: heng.p@cyclelect.com.sg

SOUTH AFRICA, Roodepoort
Yneldo Electronics
Tel: +27(0)117637053
Fax: +27(0)117634212
Website: www.yneldo.com
E-mail: yneldo@yneldo.com

SWEDEN, Kungälv
Elektrisk Drivteknik EDT AB
Tel: +46-705-28 20 60
Tel: +46-709-50 47 90
Website: www.edtab.se
E-mail: info@edtab.se

THAILAND, Bang Lamung
Semtec Maritime/Genetech Co.Ltd
Tel: +66 38301262
Fax: +1-832-221-5642
Website: semtecmaritime.com/
Email: info@semtecmaritime.com

TURKEY, Izmir
INTEGRAL
Tel: +90 (555) 211 55 75
Email: ozgur@integralguc.com

UNITED ARAB EMIRATES, Sharjah
KDU Technical Services
Tel: +971-6-5575480
Fax: +971-6-5575490
Website: www.kdutech.ae
E-mail: kdutech@kdutech.ae

UNITED KINGDOM, Stockton on Tees
MJR Controls
Tel: +44 1642 762 151
Fax: +44 1642 762 502
Website: www.mjrcontrols.com
Email: chris.milner@mjrcontrols.com

UNITED KINGDOM, Cheadle Hulme
TGS Total Generator Solutions Ltd
Tel: +44161 8188720
Fax: +447754677963
Website: <http://totalgeneratorsolutions.com>
Email: sales@totalgeneratorsolutions.com

UNITED STATES, Kemah - Texas
Ramtec Marine Systems LLC
Tel: +1-281-334-2904
Fax: +1-832-221-5642
Website: www.ramtec-marine.com
Email: waling@ramtec-marine.com